

NEWS

New range of tables and welded sinks



Our tables and welded sinks are now a structurally different product from the dismantled ones. The new entirely welded structure design offers an exceptional robustness and stability.



This state-of-the-art structure is manufactured with strongly joined tubes by means of MIG welded seams and has additional reinforcement on the countertop area as well as the lower part of the structure itself.

Industrial extractor hoods

We offer new ranges of extractor hoods, which add up to a total of 126 models, including straight central normal or compensated extractor hoods, induction extractor hoods for show cooking and vapour extractors.

Following the same process of other ranges, they are sealed welded devices of up to 6 metres and available for their immediate delivery.



NEWS

Cocktail stations

They are robust, premium stations perfectly equipped, which have been designed with the cooperation of professional barmen and comprise all the necessary characteristics to facilitate the barman's work and increase the business productivity.

They are available for delivery within 24 to 72 hours, depending on the model.

The models equipped with refrigerating drawers are extremely compact, functional working stations that reduce the space necessity in the premises as well as the overall purchase cost due to the fact that they do not require additional cooled tables.



Table MCBN-100. Basic compact and economic model for combined furniture and basic cocktail furniture.

NEWS

Ecological coolant gas R290

As an important innovation, all ERATOS refrigerating equipment are now supplied with ecological refrigerating gas R290 (propane).

Thus, in ERATOS the future is already the present. Our firm intent for a sustainable growth, R&D and continuous investment on latest-generation industrial equipment, place us in a leading edge position, always at the forefront of networking technology.

The use of gas R290 in our refrigerating products generates important economic and environmental advantages

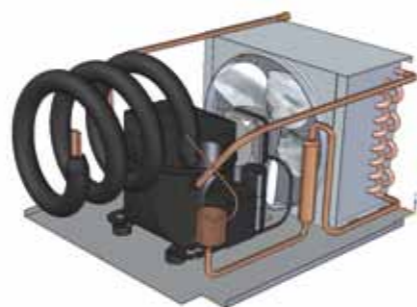

- ERATOS products with gas R290 have a price (RRP) 2% inferior to the ones with equivalent coolant gasses.
- Gas R290 is very efficient, allowing savings of 10% to 30% in electrical consumption depending on the model, seriously reducing the working cost of the product during its life span.
- The price of the gas R290 is lower compared to the more frequent fluorinated gasses (HFC), which makes it possible to reduce manufacturing costs during all the equipment life span.
- Unlike fluorinated gasses (HFC), R290 is an environmentally-friendly hydrocarbon, innocuous for the ozone layer and with a practically null GWP rate (global warming potential).

Coolant	R404A	R452A	R134a	R290
Global warming potential (GWP)	3922	2140	1540	3
Coolant	PCA ≥ 2500		PCA ≥ 150	
Forbidden from	1 January 2020		1 January 2022	

Children self-service

Innovative Children Self-service specifically designed for the catering to children of different ages, normally between 6 and 12 years old.

It is a personalized modular range which has been carefully designed to ensure children's security as well as use ergonomics.



NEWS

New drop-in models and lamp strips

ERATOS 2019 Drop-in range constitutes an utterly complete catalogue of embedding elements and lamp strips for Buffet. They are reliable products, finely finished and of easy installation.



Among our models you can find two-level cooled boards, white tempered glass hot plates, glass-ceramic hot plates for show cooking, straight refrigerated showcases and tilted lamp strips.



Modular show-cooking

The new modular show-cooking units are manufactured of premium quality material and perfectly customized aesthetically as well as functionally.

They can be supplied as independent modules or settled in lineal modules combined with ERATOS Buffet modules.

They are delivered fully mounted and have wheels, which enables an easy, ergonomic, economical, immediate installation.





Permanent investment and excellence at the service of our clients

ERATOS is composed of a team compromised with its excellence in all areas of our company. We are professionals who work with competence, responsibility and great enthusiasm to offer the best products and outstanding service to our clients.

Our new factory features leading-edge technology in management as well as in production systems. We seriously commit to sustainability and continue developing towards the digitalization of our industrial processes and a more personalized and effective relation with our clients.



We work purposefully to give our clients a close, personal approach, meeting their needs and offering the best price and personal care.



More than 90% of our available products are delivered within 24 hours and shipped by a transport company directly from the factory to the address given by the client.



Excellent products with certified quality perfectly designed and manufactured for an intensive professional use to comply with an ergonomic long-lasting function.



We invest in latest technology machinery and equipment which brings down the manufacturing process period, increases the quality of our products and considerably reduces the environmental impact in the manufacturing process.



We test prototypes in our laboratories to steadily improve our products.



Our technical department use engineering advanced programmes for the calculation, simulation and design of our products.



ERATOS is a company compromised with the people and with social, economic and environmental improvement even beyond what is legally required. We develop, sponsor and invest in numerous sustainability actions, training programmes, social aid, et

SINKS, BASINS,
INDUSTRIAL TAPS



WORKING TABLES
COCKTAIL STATION AND
RELATED MODULES



NEUTRAL AND HOT
FURNITURE



SHELVING UNITS



EXTRACTOR CANOPIES



NEUTRAL AND
HEATED TROLLEYS



GASTRONORM
CONTAINERS



DROP-IN ELEMENTS
AND SHOW COOKING
MODULAR



SELF-SERVICE





SINKS, BASINS, INDUSTRIAL TAPS

Disassembled sinks and frame supports Range 550-600	page 14
Disassembled sinks and frame supports Range 700	page 15
Disassembled high capacity sinks and frame supports	page 16
Disassembled sinks and frame supports with dishwasher shaft Range 550-600-700	page 17
Disassembled sinks and frame supports for food waste	page 18
Sinks Range 500-550 with gusset	page 19
Semi-industrial sinks with frame support Range 550	page 19
Welded sinks Range 550-600	page 20
Welded sinks Range 700	page 21
High capacity welded sinks	page 22
Welded sinks with dishwasher shaft Range 550-600-700	page 23
Welded sinks for food waste Range 600-700	page 24
Welded wall tables with well Range 600-700	page 25
Waste disposal sink	page 26
Wall frame supports for sinks	page 26
Back and sides splash for sink frame support	page 26
Taps bore	page 26
Tables for meat/fish and vegetables preparation	page 27
Stainless steel bins with wheels	page 27
Inlet/outlet dishwasher tables	page 28
Straight and curve outlet roller track table 90°	page 29
Wall shelf with baskets	page 29
Dishwasher stands	page 29
Standard and wall basins	page 30
Taps and accessories for basins	page 31
Shower taps	page 32
Taps	page 34

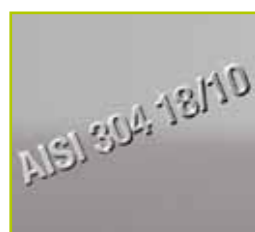

Maximum quality
Products manufactured of highest quality stainless steel AISI 304 18/10, designed with functional, elegant and uniform lines. Perfect, solid, hygienic finishes.



Sinks
Entirely welded countertops with backplash, front profile and sinks provided with rounded sanitary edges. Sound-proof embedded drainers.



Dismounted models
Our dismantled models have been designed for a quick and easy assemble of the countertop, legs and shelves, and present a robust structure. They are supplied with screws and all necessary accessories.



Welded models
Countertop and frame with or without shelf, utterly welded together to obtain a solid, stable and robust structure. Recessed back legs, height adjustable by means of un-seen screws.



Taps
Vast range of taps designed for professional use and manufactured of high quality materials that ensure their ergonomics and durability.



Uniform design
The uniform design of sinks, tables and all other products of our catalogue enables the combination of elements with total aesthetic and functional harmony, achieving elegant and practical compositions.



Wide range and availability
Our wide range of sinks, tables for dishwashers and taps provides a solution adaptable to each situation. Our permanent stock ensures immediate delivery dates.



Accessories
Our vast offer of accessories, including basins, closed cases, shelves or waste buckets enables the setting of more personalized equipment.

DISMOUNTED MODELS

DISMOUNTED SINKS 550-600-700



- These models are supplied dismantled.
- The different elements shape a very solid structure, easy and quick to assemble by means of Allen screws (Allen key included).

SINKS:

- Manufactured of satin stainless steel AISI-304 18/10.
- 100 mm backsplash and 50mm rounded fronts, entirely welded.
- Stainless steel AISI -304 18/10 embedded wells with soundproof cover, drainage valve and spillway tube.
- They can be equipped with a vast range of taps, see pages 31-35
- Optionally, all models can be supplied with a bore for tap fitting, see page 26, RRP 28 €.



SINK		FRAME SUPPORT		SHELF	
Model	RRP(€)	Model	RRP(€)	Model	RRP(€)

Dimensions	Outline	Well dimensions	SINK		FRAME SUPPORT		SHELF		
			Model	RRP(€)	Model	RRP(€)	Model	RRP(€)	
550	NEW 1000x550		340x340x200	FG-1055/11-D	253	BAD-1055	159	EB-1055	103
			340x340x200	FG-1055/11-I	253	BAD-1055	159	EB-1055	103
	NEW 1400x550		400x400x250	FG-1455/21-D	273	BAD-1455	207	EB-1455	108
			400x400x250	FG-1455/21-I	273	BAD-1455	207	EB-1455	108
600	600x600		500x400x250	FG-66/10	214	BAD-66	160	EB-66	85
	700x600		500x500x250	FG-76/10	300	BAD-76	177	EB-76	92
	1000x600		400x400x250	FG-106/11-D	302	BAD-106	189	EB-106	121
			400x400x250	FG-106/11-I	302	BAD-106	189	EB-106	121
			400x400x250	FG-106/20	432	BAD-106	189	EB-106	121
	1200x600		500x400x250	FG-126/11-D	261	BAD-126	196	EB-126	133
			500x400x250	FG-126/11-I	261	BAD-126	196	EB-126	133
			500x400x250	FG-126/20	451	BAD-126	196	EB-126	133
	1400x600		500x400x250	FG-146/11-D	364	BAD-146	235	EB-146	157
			500x400x250	FG-146/11-I	364	BAD-146	235	EB-146	157
			500x400x250	FG-146/20	494	BAD-146	235	EB-146	157
			400x400x250	FG-146/21-D	451	BAD-146	235	EB-146	157
			400x400x250	FG-146/21-I	451	BAD-146	235	EB-146	157
			400x400x250	FG-146/21-I	451	BAD-146	235	EB-146	157
	1600x600		500x400x250	FG-166/21-D	494	BAD-166	241	EB-166	171
			500x400x250	FG-166/21-I	494	BAD-166	241	EB-166	171
1800x600		500x400x250	FG-186/21-D	534	BAD-186	259	EB-186	198	
		500x400x250	FG-186/21-I	534	BAD-186	259	EB-186	198	
2000x600		500x400x250	FG-206/22	557	BAD-206	292	EB-206	207	

FRAME SUPPORTS:

- Manufactured of satin stainless steel 304 18/10 with galvanized steel backrest.
- Legs manufactured of 40x40mm tubes with adjustable end by means of sanitary unseen screw. Height adjustable between 85 and 90 cm.
- Recessed back legs, 50mm, to protect sanitary profiles on the floor.

SHELVES:

- Optional lower shelf, manufactured of satin stainless steel AISI-304 18/10, with omegas reinforcement on galvanized steel.
- Its design allows the possibility of assembling and adding to a module after assembly and when necessary.



Example of assembled sink model with frame support.



Example of assembled sink model with frame support and shelf.



SINK		FRAME SUPPORT		SHELF	
Model	RRP(€)	Model	RRP(€)	Model	RRP(€)

Dimensions	Outline	Well dimensions	SINK		FRAME SUPPORT		SHELF		
			Model	RRP(€)	Model	RRP(€)	Model	RRP(€)	
700	700x700		500x500x300	FG-77/10	312	BAD-77	185	EB-77	100
	800x700		600x500x300	FG-87/10	326	BAD-87	201	EB-87	114
	1000x700		500x500x300	FG-107/11-D	329	BAD-107	218	EB-107	130
			500x500x300	FG-107/11-I	329	BAD-107	218	EB-107	130
	1200x700		500x500x300	FG-127/11-D	302	BAD-127	231	EB-127	152
			500x500x300	FG-127/11-I	302	BAD-127	231	EB-127	152
			500x500x300	FG-127/20	498	BAD-127	231	EB-127	152
	1400x700		600x500x300	FG-147/11-D	384	BAD-147	253	EB-147	169
			600x500x300	FG-147/11-I	384	BAD-147	253	EB-147	169
			600x500x300	FG-147/20	562	BAD-147	253	EB-147	169
	1600x700		500x500x300	FG-167/21-D	518	BAD-167	271	EB-167	202
			500x500x300	FG-167/21-I	518	BAD-167	271	EB-167	202
	1800x700		500x500x300	FG-187/21-D	586	BAD-187	292	EB-187	216
			500x500x300	FG-187/21-I	586	BAD-187	292	EB-187	216
			500x500x300	FG-187/30	747	BAD-187	292	EB-187	216
	2000x700		600x500x300	FG-207/21-D	634	BAD-207	307	EB-207	223
		600x500x300	FG-207/21-I	634	BAD-207	307	EB-207	223	
2200x700		500x500x300	FG-227/22	663	BAD-227	340	EB-227	229	

DISMOUNTED MODELS

HIGH CAPACITY DISMOUNTED SINKS 550-600-700



These models are supplied dismantled. The different elements shape a very solid structure, easy and quick to assemble by means of Allen screws (Allen key included).

SINKS:

- Manufactured of satin stainless steel AISI-304 18/10.
- 100 mm backsplash and 50mm rounded fronts, entirely welded.
- Stainless steel AISI-304 18/10 embedded high capacity wells with soundproof cover, drainage valve and spillway tube.
- They can be equipped with a vast range of taps, see pages 31-35
- Optionally, all models can be supplied with a bore for tap fitting, see page 26, RRP 28 €.



FRAME SUPPORTS:

- Manufactured of stainless steel 304 18/10 with galvanized steel backrest.
- Legs manufactured of 40x40mm tubes with adjustable end by means of sanitary unseen screw. Height adjustable between 85 and 90 cm.
- Recessed back legs, 50mm, to protect sanitary profiles on the floor.

SHELVES:

- Optional lower shelf, manufactured of satin stainless steel AISI-304 18/10, with omegas reinforcement on galvanized steel.



Example of assembled sink model with frame support



Example of assembled sink model with frame support and shelf



Dimensions	Outline	Well dimensions	SINK		FRAME SUPPORT		SHELF	
			Model	RRP(€)	Model	RRP(€)	Model	RRP(€)
1000x700		800x500x350	FG-107/10	580	BAD-107	218	EB-107	130
1200x700		950x500x350	FG-127/10	650	BAD-127	231	EB-127	152
1400x700		1200x500x350	FG-147/10	686	BAD-147	253	EB-147	169
1600x700		800x500x350	FG-167/11-D	720	BAD-167	271	EB-167	202
		800x500x350	FG-167/11-I	720	BAD-167	271	EB-167	202
1800x700		800x500x350	FG-187/20	907	BAD-187	292	EB-187	216
2000x700		1200x500x350	FG-207/11-D	941	BAD-207	307	EB-207	223
		1200x500x350	FG-207/11-I	941	BAD-207	307	EB-207	223

DISMOUNTED SINKS WITH DISHWASHER SHAFT RANGE 550-600-700

DISMOUNTED MODELS



Example of assembled sink model with frame support



Example of assembled sink model with frame support and shelf

These models are supplied dismantled. The different elements shape a very solid structure, easy and quick to assemble by means of Allen screws (Allen key included).

SINKS:

- Manufactured of satin stainless steel AISI-304 18/10.
- 100 mm backsplash and 50mm rounded fronts, and entirely welded.
- Stainless steel AISI-304 18/10 embedded wells with soundproof cover, drainage valve and spillway tube.
- They can be equipped with a vast range of taps, see pages 31-35
- Optionally, all models can be supplied with a bore for tap fitting, see page 26, RRP 28€.

FRAME SUPPORTS:

- Manufactured of satin stainless steel 304 18/10 with galvanized steel backrest.
- Legs manufactured of 40x40mm tubes with adjustable end by means of sanitary hidden screw. Height adjustable between 85 and 90 cm.
- Recessed back legs 50mm to protect sanitary profiles on the floor.

SHELVES:

- Optional lower shelf, manufactured of satin stainless steel AISI-304 18/10, with strengthening omegas on galvanized steel.

Designed to accommodate a glasswasher.

Designed to accommodate a dishwasher, maximum: 600x600x850mm



Dimensions	Outline	V/P	Well dimensions	SINK		FRAME SUPPORT		SHELF		
				Model	RRP(€)	Model	RRP(€)	Model	RRP(€)	
550			340x340x200	FG-1055/11-D	253	BLD-1055	153	EBL-1055	80	
			340x340x200	FG-1055/11-I	253	BLD-1055	153	EBL-1055	80	
			400x400x250	FG-1455/21-D	273	BLD-1455	200	EBL-1455	84	
			400x400x250	FG-1455/21-I	273	BLD-1455	200	EBL-1455	84	
600			400x400x250	FG-106/11-D	302	BLD-106	170	EBL-106	85	
			400x400x250	FG-106/11-I	302	BLD-106	170	EBL-106	85	
			500x400x250	FG-126/11-D	261	BLD-126	174	EBL-126	86	
			500x400x250	FG-126/11-I	261	BLD-126	174	EBL-126	86	
			500x400x250	FG-146/11-D	364	BLD-146	209	EBL-146	102	
			500x400x250	FG-146/11-I	364	BLD-146	209	EBL-146	102	
				500x400x250	FG-186/21-D	534	BLD-186	265	EBL-186	133
				500x400x250	FG-186/21-I	534	BLD-186	265	EBL-186	133
700			500x500x300	FG-127/11-D	302	BLD-127	180	EBL-127	89	
			500x500x300	FG-127/11-I	302	BLD-127	180	EBL-127	89	
			600x500x300	FG-147/11-D	384	BLD-147	215	EBL-147	114	
			600x500x300	FG-147/11-I	384	BLD-147	215	EBL-147	114	
			500x500x300	FG-187/21-D	586	BLD-187	270	EBL-187	152	
			500x500x300	FG-187/21-I	586	BLD-187	270	EBL-187	152	

DISMOUNTED MODELS

DISMOUNTED SINKS WITH FOOD WASTE BORE

These models are supplied dismounted. The different elements shape a very solid structure, easy and quick to assemble by means of Allen screws (Allen key included).

SINKS:

- Manufactured of satin stainless steel AISI-304 18/10.
- 100 mm backsplash and 50mm rounded fronts, entirely welded.
- Stainless steel AISI -304 18/10 embedded wells with sound-proof cover, drainage valve and spillway tube.
- Embedded waste food bore with removable grey rubber ring Ø 200mm flush mounted with the countertop to throw wastes into the waste bin situated under the sink.
- They can be equipped with a vast range of taps, see pages 31-35
- Optionally, all models can be supplied with a bore for tap fitting, see page 26, RRP 28 €.

FRAME SUPPORTS:

- Manufactured of satin stainless steel 304 18/10 with galvanized steel backrest.
- Legs manufactured of 40x40mm tubes with adjustable end by means of sanitary unseen screw. Height adjustable between 85 and 90 cm.
- Recessed back legs, 50mm, to protect sanitary profiles on the floor.
- The dishwasher frame supports easily accommodate standard models of up to 600x600x850mm.
- Designed to accommodate a waste bin, (not included), see page 27.



Example of assembled model for dishwasher (bin not included in the price)



Example of assembled sink model with frame support



	Dimensions	Outline	Well dimensions	SINK		FRAME SUPPORT		FRAME SUPPORT DISHWASHER	
				Model	RRP(€)	Model	RRP(€)	Model	RRP(€)
600	1800x600		500x400x250	FG-186/111-D	656	BDD-186	349	BDLD-186	298
			500x400x250	FG-186/111-I	656	BDD-186	349	BDLD-186	298
700	1400x700		600x500x300	FG-147/101-D	492	BDD-147	254	-	-
			600x500x300	FG-147/101-I	492	BDD-147	254	-	-
	1800x700		500x500x300	FG-187/111-D	697	BDD-187	394	BDLD-187	312
			500x500x300	FG-187/111-I	697	BDD-187	394	BDLD-187	312

INDUSTRIAL SINKS RANGE 550 AND SEMI INDUSTRIAL RANGE 500 WITH GUSSET

NEW

- Countertops manufactured of stainless steel AISI-304 18/10 with embedded wells.
- The industrial models of 550 mm are manufactured with 100 mm backsplash and 50mm rounded fronts, entirely welded.
- Models of 500mm have a 40mm backsplash.
- All models have gussets for wall mounting.



FC-1055/11-D



FC-1050/11-D

	Dimensions	Outline	Model	Wells dimension	Glass washer bore	RRP (€)
550	1000x550		FC-1055/11-D	340x340x200	YES	327
			FC-1055/11-I	340x340x200	YES	327
	1400x550		FC-1455/21-D	400x400x250	YES	347
			FC-1455/21-I	400x400x250	YES	347
500	800x500		FC-850/11-D	340x370x150	NO	409
			FC-850/11-I	340x370x150	NO	409
	1000x500		FC-1050/11-D	340x370x150	500x500x800	424
			FC-1050/11-I	340x370x150	500x500x800	424
	1350x500		FC-1350/21-D	340x370x150	500x500x800	454
			FC-1350/21-I	340x370x150	500x500x800	454

SEMI INDUSTRIAL SINKS RANGE 500 WITH FRAME SUPPORT



- Countertops and frame supports entirely manufactured of stainless steel AISI-304 18/10 with 40 mm backsplash.
- Well of 340x370x150mm. It includes valve and drainage plug.
- Frame support manufactured of stainless steel 304 18/10, 30x30mm, with height adjustable legs and 100mm front spoiler.
- Suitable to easily accommodate glasswasher under its structure (except for model FB-859).

	Dimensions	Outline	Model	Wells dimension	Glass washer bore	RRP (€)
500	800x500		FB-850/11-D	340x370x150	NO	335
			FB-850/11-I	340x370x150	NO	335
500	1000x500		FB-1050/11-D	340x370x150	500x500x750	350
			FB-1050/11-I	340x370x150	500x500x750	350
	1350x500		FB-1350/21-D	340x370x150	500x500x750	380
			FB-1350/21-I	340x370x150	500x500x750	380

WELDED MODELS

WELDED SINKS RANGE 550-600-700



- This range of models is supplied utterly welded.
- The new design and quality of its materials give them a maximum robustness and stability.
- 3 manufacturing possibilities:
 1. Models with frame support.
 2. Models with frame support + shelf.
 3. Completely closed cases with doors.
- Sink manufactured of stainless steel AISI-304 18/10 with 100 mm backsplash and 50mm rounded fronts, entirely welded.
- Embedded wells with soundproof cover, drainage valve and spillway tube.
- Recessed back legs, 50mm, to protect sanitary profiles on the floor.

- Legs manufactured of 40x40mm tubes with adjustable end by means of sanitary unseen screw. Height adjustable between 85 and 90 cm.
- Shelves manufactured of satin stainless steel AISI-304 18/10, with omegas reinforcement on galvanized steel.
- They can be equipped with a vast range of taps, see pages 31-35.
- Optionally, all models can be supplied with a bore for tap fitting, see page 26, RRP 28 €.



SINK CASE WITH DOORS

- This range of models is supplied utterly mounted and welded to the sink and the base shelf.
- Open back to allow easy access to fittings.
- Robust height adjustable legs by means of sanitary unseen screw.
- Height adjustable between 85 and 90 cm.
- Smooth-slide suspended sliding doors by means of rail with ball bearing, except for model FMM-66 /10 with hinged door.
- Option: key lock on doors. Ref. OCPC: 88 €.



SINK WITH FRAME SUPPORT		SINK WITH FRAME SUPPORT AND SHELF		SINK WITH CASE	
Model	RRP(€)	Model	RRP(€)	Model	RRP(€)

Dimensions	Outline	Well dimensions	SINK WITH FRAME SUPPORT		SINK WITH FRAME SUPPORT AND SHELF		SINK WITH CASE		
			Model	RRP(€)	Model	RRP(€)	Model	RRP(€)	
550	1000x550		FMB-1055/11-D	459	FME-1055/11-D	562	-	-	
			FMB-1055/11-I	459	FME-1055/11-I	562	-	-	
	1400x550		FMB-1455/21-D	538	FME-1455/21-D	646	-	-	
			FMB-1455/21-I	538	FME-1455/21-I	646	-	-	
600	600x600		FMB-66/10	421	FME-66/10	506	FMM-66/10	801	
	700x600		FMB-76/10	524	FME-76/10	616	-	-	
	1000x600		400x400x250	FMB-106/11-D	538	FME-106/11-D	659	FMM-106/11-D	1.067
			400x400x250	FMB-106/11-I	538	FME-106/11-I	659	FMM-106/11-I	1.067
			400x400x250	FMB-106/20	668	FME-106/20	789	FMM-106/20	1.197
	1200x600		500x400x250	FMB-126/11-D	515	FME-126/11-D	648	FMM-126/11-D	1.080
			500x400x250	FMB-126/11-I	515	FME-126/11-I	648	FMM-126/11-I	1.080
			500x400x250	FMB-126/20	705	FME-126/20	838	FMM-126/20	1.269
	1400x600		500x400x250	FMB-146/11-D	657	FME-146/11-D	814	FMM-146/11-D	1.236
			500x400x250	FMB-146/11-I	657	FME-146/11-I	814	FMM-146/11-I	1.236
			500x400x250	FMB-146/20	787	FME-146/20	944	FMM-146/20	1.366
			400x400x250	FMB-146/21-D	744	FME-146/21-D	901	FMM-146/21-D	1.353
			400x400x250	FMB-146/21-I	744	FME-146/21-I	901	FMM-146/21-I	1.353
			500x400x250	FMB-166/21-D	806	FME-166/21-D	977	FMM-166/21-D	1.449
	1600x600		500x400x250	FMB-166/21-I	806	FME-166/21-I	977	FMM-166/21-I	1.449
			500x400x250	FMB-186/21-D	864	FME-186/21-D	1.062	FMM-186/21-D	1.541
1800x600		500x400x250	FMB-186/21-I	864	FME-186/21-I	1.062	FMM-186/21-I	1.541	
		500x400x250	FMB-206/22	947	FME-206/22	1.154	FMM-206/22	1.625	

SINK WITH FRAME SUPPORT		SINK WITH FRAME SUPPORT AND SHELF		SINK WITH CASE	
Model	RRP(€)	Model	RRP(€)	Model	RRP(€)

Dimensions	Outline	Well dimensions	SINK WITH FRAME SUPPORT		SINK WITH FRAME SUPPORT AND SHELF		SINK WITH CASE	
			Model	RRP(€)	Model	RRP(€)	Model	RRP(€)
700x700		500x500x300	FMB-77/10	544	FME-77/10	644	-	-
800x700		600x500x300	FMB-87/10	574	FME-87/10	688	FMM-87/10	1.135
1000x700		500x500x300	FMB-107/11-D	594	FME-107/11-D	724	FMM-107/11-D	1.119
		500x500x300	FMB-107/11-I	594	FME-107/11-I	724	FMM-107/11-I	1.119
1200x700		500x500x300	FMB-127/11-D	591	FME-127/11-D	743	FMM-127/11-D	1.181
		500x500x300	FMB-127/11-I	591	FME-127/11-I	743	FMM-127/11-I	1.181
		500x500x300	FMB-127/20	786	FME-127/20	938	FMM-127/20	1.377
1400x700		600x500x300	FMB-147/11-D	695	FME-147/11-D	864	FMM-147/11-D	1.291
		600x500x300	FMB-147/11-I	695	FME-147/11-I	864	FMM-147/11-I	1.291
		600x500x300	FMB-147/20	873	FME-147/20	1.042	FMM-147/20	1.470
1600x700		500x500x300	FMB-167/21-D	860	FME-167/21-D	1.062	FMM-167/21-D	1.489
		500x500x300	FMB-167/21-I	860	FME-167/21-I	1.062	FMM-167/21-I	1.489
1800x700		500x500x300	FMB-187/21-D	949	FME-187/21-D	1.165	FMM-187/21-D	1.608
		500x500x300	FMB-187/21-I	949	FME-187/21-I	1.165	FMM-187/21-I	1.608
		500x500x300	FMB-187/30	1.110	FME-187/30	1.326	FMM-187/30	1.769
2000x700		600x500x300	FMB-207/21-D	1.039	FME-207/21-D	1.262	FMM-207/21-D	1.705
		600x500x300	FMB-207/21-I	1.039	FME-207/21-I	1.262	FMM-207/21-I	1.705
2200x700		500x500x300	FMB-227/22	1.101	FME-227/22	1.330	-	-

WELDED MODELS

HIGH CAPACITY WELDED SINKS

These models are supplied utterly welded.

SINKS WITH FRAME SUPPORT:

- Manufactured of satin stainless steel AISI-304 18/10.
- 100 mm backsplash and 50mm rounded fronts, and entirely welded.
- Stainless steel AISI -304 18/10 embedded wells with sound-proof cover, drainage valve and spillway tube.
- They can be equipped with a vast range of taps, see pages 31-35
- Optionally, all models can be supplied with a bore for tap fitting, see page 26, RRP 28 €.
- The frame support is manufactured of satin stainless steel 304 18/10 with galvanized steel backrest. Legs manufactured of 40x40mm tubes with adjustable end by means of sanitary unseen screw. Height adjustable between 85 and 90 cm.



Module with frame support and shelf



Module with frame support



Sink case with doors



Dimensions	Outline	Well dimensions	SINK WITH FRAME SUPPORT		SINK WITH FRAME SUPPORT AND SHELF		SINK WITH CASE	
			Model	RRP(€)	Model	RRP(€)	Model	RRP(€)
1000x700		800x500x350	FMB-107/10	845	FME-107/10	975	FMM-107/10	1.370
1200x700		950x500x350	FMB-127/10	939	FME-127/10	1.091	FMM-127/10	1.529
1400x700		1200x500x350	FMB-147/10	997	FME-147/10	1.166	FMM-147/10	1.594
1600x700		800x500x350	FMB-167/11-D	1.062	FME-167/11-D	1.264	FMM-167/11-D	1.691
			FMB-167/11-I	1.062	FME-167/11-I	1.264	FMM-167/11-I	1.691
1800x700		800x500x350	FMB-187/20	1.270	FME-187/20	1.422	FMM-187/20	1.961
			FMB-207/11-D	1.346	FME-207/11-D	1.569	FMM-207/11-D	1.980
2000x700		1200x500x350	FMB-207/11-D	1.346	FME-207/11-D	1.569	FMM-207/11-D	1.980
			FMB-207/11-I	1.430	FME-207/11-I	1.632	FMM-207/11-I	2.019

SHELVES:

There are models with lower shelf welded to the 4 legs, which enlarges its life span and gives it more robustness.

SINK CASE:

- It is supplied mounted and welded to the sink.
- Without backrest to allow easy access to fittings.
- Robust height adjustable legs by means of sanitary unseen screw. Adjustable height between 85 and 90 cm.
- Smooth-slide suspended sliding doors by means of rail with ball bearing.
- Optional: key lock on doors. Ref. OCPC: 88 €.

WELDED MODELS

WELDED SINKS WITH DISHWASHER SHAFT RANGE 550-600-700



These models are supplied utterly welded.

SINKS WITH FRAME SUPPORT:

- Manufactured of stainless steel AISI-304 18/10.
- 100 mm backsplash and 50mm rounded fronts, entirely welded.
- Stainless steel AISI -304 18/10 embedded wells with sound-proof cover, drainage valve and spillway tube.
- Frame support manufactured of satin stainless steel 304 18/10 with galvanized steel backrest. Legs manufactured of 40x40mm tubes with adjustable end by means of sanitary unseen screw. Height adjustable between 85 and 90 cm. Recessed back legs, 50mm, to protect sanitary profiles on the floor.

DISHWASHER SINK CASE WITH DOORS:

- It is supplied mounted and welded to the sink.
- Without backrest to allow easy access to fittings.
- Robust height adjustable legs by means of sanitary unseen screw. Adjustable height between 85 and 90 cm.
- Hinged doors with the possibility of key lock. Ref. OCPB: 35 €.
- Models FMLM-186 and FMLM-187: Suspended sliding doors by means of rail with ball bearing. Optionally, key lock OCPC: 88 €

SHELVES:

There are models with lower shelf welded to the 4 legs, which enlarges its life span and gives it more robustness.

Designed to accommodate a glasswasher.

Designed to accommodate a dishwasher, maximum: 600x600x850mm.



Dimensions	Outline	V/P	Well dimensions	SINK WITH FRAME SUPPORT		SINK WITH FRAME SUPPORT AND SHELF		SINK WITH CASE	
				Model	RRP(€)	Model	RRP(€)	Model	RRP(€)
550			340x340x200	FMBL-1055/11-D	453	FMEL-1055/11-D	533	-	-
				FMBL-1055/11-I	453	FMEL-1055/11-I	533	-	-
			400x400x250	FMBL-1455/21-D	531	FMEL-1455/21-D	615	-	-
				FMBL-1455/21-I	531	FMEL-1455/21-I	615	-	-
600			400x400x250	FMBL-106/11-D	519	FMEL-106/11-D	604	-	-
				FMBL-106/11-I	519	FMEL-106/11-I	604	-	-
			500x400x250	FMBL-126/11-D	493	FMEL-126/11-D	578	FMLM-126/11-D	866
				FMBL-126/11-I	493	FMEL-126/11-I	578	FMLM-126/11-I	866
			500x400x250	FMBL-146/11-D	631	FMEL-146/11-D	733	FMLM-146/11-D	1.174
				FMBL-146/11-I	631	FMEL-146/11-I	733	FMLM-146/11-I	1.174
			500x400x250	FMBL-186/21-D	870	FMEL-186/21-D	1.003	FMLM-186/21-D	1.371
				FMBL-186/21-I	870	FMEL-186/21-I	1.003	FMLM-186/21-I	1.371
700			500x500x300	FMBL-127/11-D	540	FMEL-127/11-D	629	FMLM-127/11-D	925
				FMBL-127/11-I	540	FMEL-127/11-I	629	FMLM-127/11-I	925
			600x500x300	FMBL-147/11-D	651	FMEL-147/11-D	765	FMLM-147/11-D	1.193
				FMBL-147/11-I	651	FMEL-147/11-I	765	FMLM-147/11-I	1.193
			500x500x300	FMBL-187/21-D	927	FMEL-187/21-D	1.079	FMLM-187/21-D	1.483
				FMBL-187/21-I	927	FMEL-187/21-I	1.079	FMLM-187/21-I	1.483

WELDED MODELS

WELDED SINKS WITH FOOD WASTE BORE RANGE 600-700

These models are supplied entirely welded.

SINKS WITH FRAME SUPPORT:

- The countertop with sinks and waste bore are manufactured of satin stainless steel AISI-304 18/10.
- 100 mm backsplash and 50mm rounded fronts, and entirely welded.
- Stainless steel AISI -304 18/10 embedded wells with sound-proof cover, drainage valve and spillway tube.
- Embedded waste food bore with removable grey rubber ring flushed with the countertop.
- They can be equipped with a vast range of taps, see pages 31-35.

- Optionally, all models can be supplied with a bore for tap fitting, see page 26, RRP 28 €.
- Frame support manufactured of satin stainless steel 304 18/10 with galvanized steel backrest. Legs manufactured of 40x40mm tubes with adjustable end by means of sanitary unseen screw and height adjustable between 85 and 90 cm. Recessed back legs, 50mm, to protect sanitary profiles on the floor.
- The dishwasher frame supports easily accommodate standard models of up to 600x600x850mm.
- Designed to accommodate a waste bin, (not included), see page 27.



Waste bin not included in the price



Dimensions	Outline	Well dimensions	SINK WITH FRAME SUPPORT		FRAME SUPPORT DISHWASHER	
			Model	RRP (€)	Model	RRP (€)
600	1800x600	500x400x250	FMBD-186/111-D	1.076	FMBDL-186/111-D	1.025
		500x400x250	FMBD-186/111-I	1.076	FMBDL-186/111-I	1.025
700	1400x700	600x500x300	FMBD-147/101-D	804	-	-
		600x500x300	FMBD-147/101-I	804	-	-
700	1800x700	500x500x300	FMBD-187/111-D	1.162	FMBDL-187/111-D	1.080
		500x500x300	FMBD-187/111-I	1.162	FMBDL-187/111-I	1.080

WELDED MODELS

WELDED TABLES WITH WELL RANGE 600-700

- Countertop and shelves manufactured of satin stainless steel AISI-304 18/10 and with omegas reinforcement.
- Entirely welded structure. For dismantled models, see page 44.
- 100 mm backsplash and 50mm rounded fronts, entirely welded.
- Stainless steel AISI -304 18/10 embedded wells 400x400x250mm with drainage and soundproof cover.
- On tables without shelves, a reinforcement 40x40mm tube is added which gives them excellent robustness.
- Stainless steel legs manufactured of 40x40mm tubes with adjustable end by means of sanitary unseen screw.
- Counter bore Ø35mm for tap fitting.

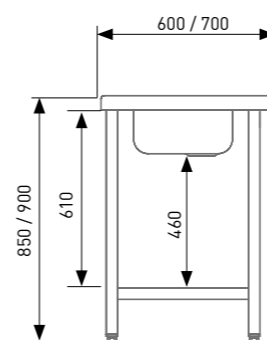

Dimensions	TABLES WITH SHELVES				TABLES WITH REINFORCEMENT				
	Right well	Central well	Left well	RRP (€)	Right well	Central well	Left well	RRP (€)	
600	1000x600x600	MCC60-100DE	MCC60-100CE	MCC60-100IE	620	MCC60-100D	MCC60-100C	MCC60-100I	605
	1200x600x600	MCC60-120DE	MCC60-120CE	MCC60-120IE	651	MCC60-120D	MCC60-120C	MCC60-120I	635
	1400x600x600	MCC60-140DE	MCC60-140CE	MCC60-140IE	685	MCC60-140D	MCC60-140C	MCC60-140I	667
	1500x600x600	MCC60-150DE	MCC60-150CE	MCC60-150IE	706	MCC60-150D	MCC60-150C	MCC60-150I	682
	1600x600x600	MCC60-160DE	MCC60-160CE	MCC60-160IE	726	MCC60-160D	MCC60-160C	MCC60-160I	692
	1800x600x600	MCC60-180DE	MCC60-180CE	MCC60-180IE	790	MCC60-180D	MCC60-180C	MCC60-180I	745
	2000x600x600	MCC60-200DE	MCC60-200CE	MCC60-200IE	854	MCC60-200D	MCC60-200C	MCC60-200I	813
	2200x600x600	MCC60-220DE	MCC60-220CE	MCC60-220IE	993	MCC60-220D	MCC60-220C	MCC60-220I	938
2400x600x600	MCC60-240DE	MCC60-240CE	MCC60-240IE	1009	MCC60-240D	MCC60-240C	MCC60-240I	953	
700	1000x700x850	MCC70-100DE	MCC70-100CE	MCC70-100IE	653	MCC70-100D	MCC70-100C	MCC70-100I	633
	1200x700x850	MCC70-120DE	MCC70-120CE	MCC70-120IE	690	MCC70-120D	MCC70-120C	MCC70-120I	674
	1400x700x850	MCC70-140DE	MCC70-140CE	MCC70-140IE	739	MCC70-140D	MCC70-140C	MCC70-140I	716
	1500x700x850	MCC70-150DE	MCC70-150CE	MCC70-150IE	760	MCC70-150D	MCC70-150C	MCC70-150I	731
	1600x700x850	MCC70-160DE	MCC70-160CE	MCC70-160IE	775	MCC70-160D	MCC70-160C	MCC70-160I	737
	1800x700x850	MCC70-180DE	MCC70-180CE	MCC70-180IE	842	MCC70-180D	MCC70-180C	MCC70-180I	781
	2000x700x850	MCC70-200DE	MCC70-200CE	MCC70-200IE	901	MCC70-200D	MCC70-200C	MCC70-200I	857
	2200x700x850	MCC70-220DE	MCC70-220CE	MCC70-220IE	1.008	MCC70-220D	MCC70-220C	MCC70-220I	973
2400x700x850	MCC70-240DE	MCC70-240CE	MCC70-240IE	1.030	MCC70-240D	MCC70-240C	MCC70-240I	1.001	



WASTE DISPOSAL SINK

- Manufactured entirely of stainless steel AISI-304 18/10.
- Stainless steel AISI -304 18/10 embedded wells, drainage valve and spillway tube; 500x400x250mm (Range 600) or 500x500x300mm (Range 700).
- Frame support included in the price.
- Height adjustable legs manufactured by means of sanitary unseen screw.
- It includes removable grille for big containers' support.

	Model	Dimensions	Frame support	RRP (€)
600	FVD-66/10	600x600x500	Disassembled	421
	FV-66/10	600x600x500	Welded	468
700	FVD-77/10	700x700x500	Disassembled	478
	FV-77/10	700x700x500	Welded	525

WALL STANDS

- Manufactured of stainless steel AISI-304 18/10.
- Removable height adjustable leg.
- Apt for countertops and sinks 600 and 700mm deep

Model	Dimensions	Description	RRP (€/ud)
SM	410x580	Wall stand	95
SMP	410x830	Wall stand with leg	122

BACK AND SIDES SPLASH FOR SINKS

- Manufactured of satin stainless steel AISI-304 18/10.
- They can be integrated into any of ERATOS sinks.
- Easily assembled.

	Model	Dimensions	Description	RRP (€)
600	PLF-60	600x600	Side splash	66
	PL-60D	600x100	Right side splash	101
	PL-60I	600x100	Peto izquierdo	101
700	PLF-70	600x700	Side splash	75
	PL-70D	700x100	Right side splash	109
	PL-70I	700x100	Left side splash	109

TAPS BORE

- Ø 35mm bore.
- Note: When a sink with frame support with dishwasher shaft is fitted, the bore will not be drilled between the well and the drainer.

Model	Position	Description	RRP (€)
OAG-D		Bore to the right of the well	28
OAG-C		Bore in the centre of the well	28
OAG-I		Bore to the left of the well	28
OAG-E		Tap bore between the wells	28



TABLES FOR FISH AND MEET PREPARATION

- Manufactured of satin stainless steel AISI-304 18/10.
- 100 mm backsplash and 50mm rounded fronts, entirely welded.
- Cutting polyethylene sheet and waste disposal bore.
- Counter recess with drainage and removable drilled grille.
- Stainless steel legs manufactured of 40x40mm tubes with adjustable end by means of sanitary unseen screw.
- Designed to accommodate a waste bin (not included).
- The welded frame support is supplied utterly assembled and entirely welded to the countertop.

Model	Dimensions	Description	RRP (€)
EPC-147	1400x700	Countertop	861
BPD-147	1400x700	Dismounted frame support	262
BP-147	1400x700	Welded frame support	321

TABLES FOR VEGETABLE PREPARATION

- Manufactured of satin stainless steel AISI-304 18/10.
- 100 mm backsplash and 50mm rounded fronts, entirely welded.
- Cutting polyethylene sheet and waste disposal bore.
- Well, 1200x310x170mm, with drainage and possibility of overlapping wells GN1/3, 1/2, 1/1, 2/3.
- Stainless steel legs manufactured of 40x40mm tubes with adjustable end by means of sanitary unseen screw.
- Designed to accommodate a waste bin (not included).
- The welded frame support is supplied utterly assembled and entirely welded to the countertop.

Model	Dimensions	Description	RRP (€)
EPV-147	1400x700	Countertop	885
BPD-147	1400x700	Dismounted frame support	262
BP-147	1400x700	Welded frame support	321

STAINLESS STEEL BIN WITH WHEELS

- Manufactured of stainless steel AISI-304 18/10.
- Embedded bottom to facilitate cleaning.
- Models CC-50 and CC-100 bear removable lid.
- Models CCP-100 and SB-100 are equipped with pedal operation lid.
- Available in two capacities: 50 and 100L.
- With wheels Ø50mm.

Model	Dimensions	Description	RRP (€)
CC-50	Ø380x605 (50 L.)	Without pedal	179
CC-100	Ø450x685 (100 L.)	Without pedal	210
CCP-100	Ø450x685 (100 L.)	With pedal	248
SB-100	Ø410x850 (100 L.)	Bag support with pedal	235



Waste bin not included in the price



Waste bin not included in the price



CC-50

CC-100

CCP-100

SB-100

DISHWASHER TABLES



- Manufactured of satin stainless steel AISI-304 18/10.
- Oversized backsplash 150mm and 50mm rounded fronts, entirely welded.
- Universal coupling adjustable to any dishwasher.
- Stainless steel AISI-304 18/10 embedded 500x400x250mm wells with soundproof cover, drainage valve and spillway tube.
- Embedded waste food bore with removable grey rubber ring Ø200mm flushed with the countertop.
- Legs manufactured of 40x40mm tubes with adjustable end by means of sanitary unseen screw.
- Easy and quick to assemble.
- The lower shelf is independent but its design allows dishwasher screwing.

Universal coupling adjustable to any dishwasher

PRE-WASHING TABLES

	Outline	Dimensions	WITH SHELF		WITHOUT SHELF	
			Model	RRP (€)	Model	RRP (€)
WITH SINK		800x750x850	MP-80D	1.030	MPS-80D	892
		800x750x850	MP-80I	1.030	MPS-80I	892
		1200x750x850	MP-120D	1.098	MPS-120D	936
		1200x750x850	MP-120I	1.098	MPS-120I	936
WITH SINK & BORE FOR WASTE		1600x750x850	MP-160D	1.217	MPS-160D	1.025
		1600x750x850	MP-160I	1.217	MPS-160I	1.025
		1200x750x850	MPD-120D	1.181	MPDS-120D	1.114
		1200x750x850	MPD-120I	1.181	MPDS-120I	1.114
		1600x750x850	MPD-160D	1.301	MPDS-160D	1.259
		1600x750x850	MPD-160I	1.301	MPDS-160I	1.259
		2100x750x850	MPD-210D	1.428	MPDS-210D	1.401
		2100x750x850	MPD-210I	1.428	MPDS-210I	1.401

INLET/OUTLET DISHWASHER TABLES

	Outline	Dimensions	WITH SHELF		WITHOUT SHELF	
			Model	RRP (€)	Model	RRP (€)
CENTRAL		600x600	-	-	MES-60	-
WALL		800x750x850	ME-80D	763	MES-80D	607
		800x750x850	ME-80I	763	MES-80I	607
		1200x750x850	ME-120D	832	MES-120D	652
		1200x750x850	ME-120I	832	MES-120I	652
		1600x750x850	ME-160D	951	MES-160D	740
		1600x750x850	ME-160I	951	MES-160I	740

STRAIGHT OUTLET ROLLER TRACK TABLE

- Manufactured of satin stainless steel AISI-304 18/10.
- Removable PVC roller track with stainless steel axe.
- Universal coupling adjustable to any dishwasher.
- They can be latched to any other table with straight or curved roller track.
- Solid removable structure with legs manufactured of 40x40mm tubes with adjustable end by means of sanitary unseen screw.
- Easy and quick to assemble with included hardware.

Model	Dimensions	RRP (€)
MR-110	1100x640x850	1.138
MR-160	1600x640x850	1.379

OUTLET ROLLER TRACK TABLE

- Manufactured of satin stainless steel AISI-304 18/10.
- Removable PVC roller track with stainless steel axe.
- Universal coupling adjustable to any dishwasher.
- They can be latched to any other tables with straight or curved roller track.
- It includes a straight reversible section, 300mm which must be placed at the entrance to enable an adequate basket circulation.
- Solid removable structure with legs manufactured of 40x40mm tubes with adjustable end by means of sanitary unseen screw.
- Easy and quick to assemble (hardware included).

Model	Dimensions	RRP (€)
CR-90	(300+965)x965x850	2.005

WALL BASKET SHELF

- Manufactured of satin stainless steel AISI-304 18/10.
- Utterly welded with embedded drainage.
- Easy and quick to assemble (included hardware).

Model	Dimensions	RRP (€)
EMCL-110	1100x480x300	315
EMCL-160	1600x480x300	389

DISHWASHER STAND

- Manufactured of satin stainless steel AISI-304 18/10.
- Solid removable structure with legs manufactured of 40x40mm tubes with adjustable end by means of sanitary unseen screw.
- Model PG-60 includes rails to accommodate a standard basket 500x500mm.
- Apt for standard dishwasher 600x600mm.

Model	Dimensions	Type	RRP (€)
PE-60	600x555x400	Without rail	208
PG-60	600x555x400	With rail	236





STANDARD BASINS

- Manufactured of satin stainless steel AISI-304 18/10.
- Embedded well and entirely welded corners.
- Front registry door.
- Integrated foot switch and spout with revolving base.
- Model LP-54G and LPD-54G integrate electronic tap.
- Models LPD integrate soap dispenser.
- Cold/hot water mixer.
- **They are supplied ready to install, including assembled hoses and accessories.**

STANDARD BASIN

Model	Dimensions	Description	RRP (€)
LP-54	500x450x850	Spout with revolving base	344
LP-54G	500x450x850	Electronic tap	570

STANDARD BASIN WITH SOAP DISHWASHER

Model	Dimensions	Description	RRP (€)
LPD-54	500x450x850	Spout with revolving base	428
LPD-54G	500x450x850	Electronic tap	654

WALL BASINS



- Manufactured of satin stainless steel AISI-304 18/10.
- Embedded well and entirely welded corners.
- Integrated knee switch and revolving spout.
- Model LM-54 can be equipped with electronic tap.
- They are supplied easy to install, including assembled hoses and accessories.
- Model LMD integrate a soap dispenser.

Model	Dimensions	Description	RRP (€)
LM-33	400x300x230	Spout with revolving base	203
LM-54	500x450x230	Spout with revolving base	240
LM-54G	500x450x230	Electronic tap (AC/DC)	466
LMD-54	500x450x230	Spout with revolving base + soap dispenser	324
LMD-54G	500x450x230	Electronic tap + soap dispenser	550

BASIN BACKSPLASH



- Manufactured of satin stainless steel AISI-304 18/10.
- Easy to assemble, without seen screws.
- Apt for all models (except LM-33)

Model	Dimensions	RRP (€)
PTL-54	500x600	54

BASIN TAPS AND ACCESSORIES

ELECTRONIC TAP GE AC/DC

- Mixed system model apt for battery/electric use.
- Manufactured of bronze with electrolytic chrome finish.
- Electronic sensor with 25 cm detection distance.
- Mixing valve not included.
- Protection: IP56.

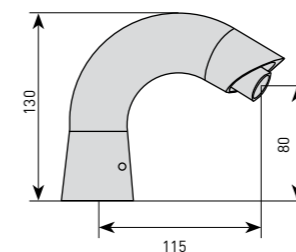

PSM

PDM

PSA



CLG

VMA

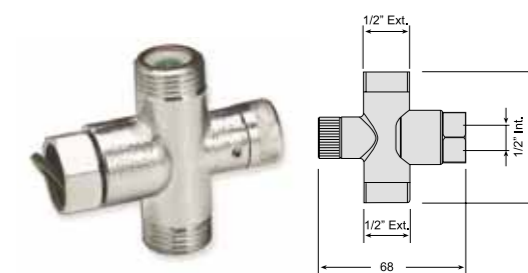
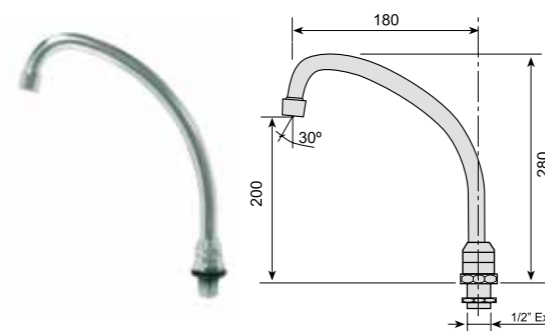

DGD

TF



Model	Description	RRP (€)
GE AC/DC	Mixed system electronic tap (batteries/electricity)	198
PSM	Hot/cold water auto-mixer tap, 1 pedal	147
PDM	Hot/cold water mixer tap, 2 pedals	137
PSA	Simple hot/cold auto-mixer tap, 1 pedal	84
CLG	Revolving hand wash spout	27
VMA	Mixer valve with regulator and check valve	29
DGD	Spray faucet system	80
TF	Flexible hose for shower faucet 1000mm	26

SHOWER FAUCETS

- High quality complete range of shower faucets designed for professional use, ergonomic and durable.
- Manufactured of chromed brass of high density and thickness.
- Ergonomic shower with thermal-protection plastic, flow regulator and check valve.
- It includes flexible hose and all necessary accessories.
- There are models with or without included intermediate faucet.

- The design of the handles allows an easy opening, regulation and closing.
- The range includes mixer taps, and models with opening 1/4 swivel range handles.
- The faucets with 1/4 swivel handle and ceramic cartridge allow a quick simple opening.

GD-0 GD-1 GD-1G GD-2 GD-2G

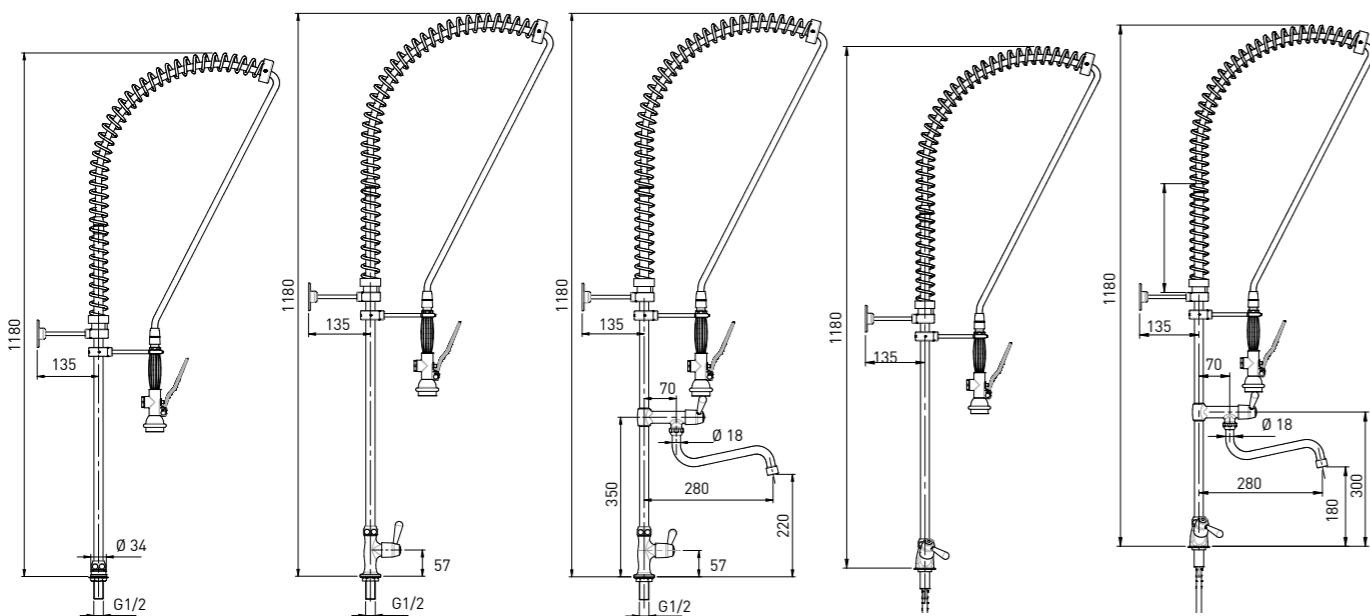

Model	Description	RRP (€)
GD-0	Direct water shower faucet	162
GD-1	Hot or cold water shower faucet with 1/4 swivel handle	191
GD-1G	Hot or cold water shower faucet with auxiliary tap with 1/4 swivel handles	251
GD-2	Hot/Cold water with 1/4 swivel handles	214
GD-2G	Hot/Cold water shower faucet with auxiliary tap with 1/4 swivel handles	278

GD-M GD-MG GDPL-MG GDB-2 GDM-MG

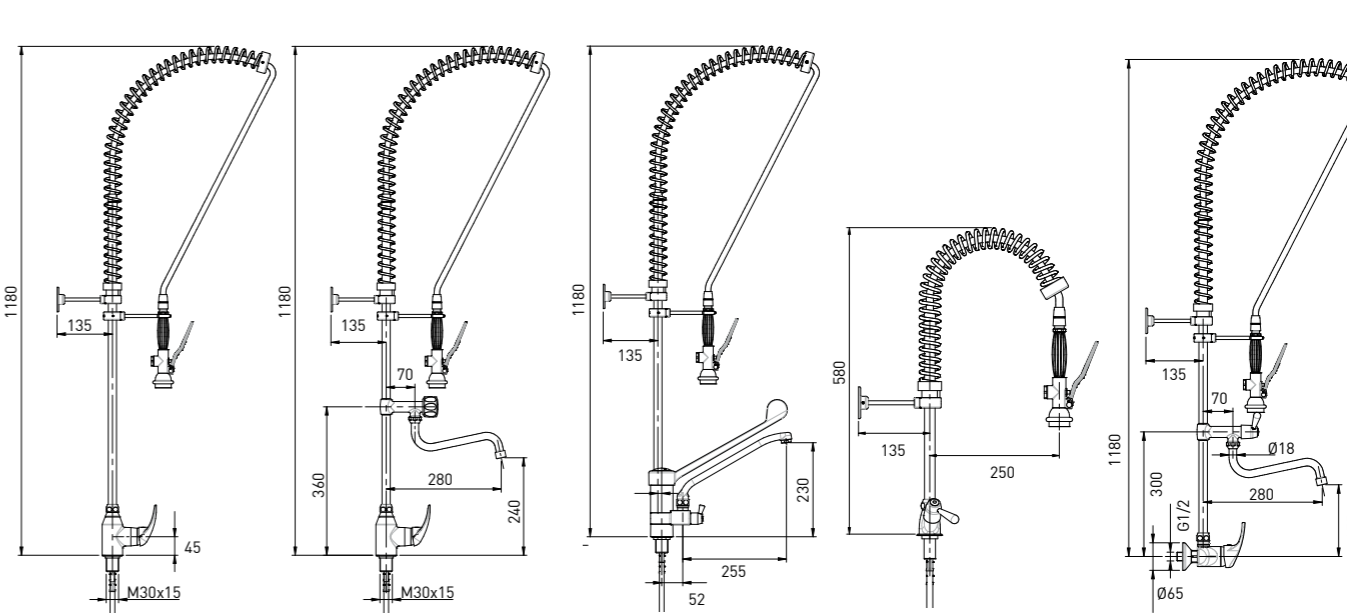

Model	Description	RRP (€)
GD-M	Hot/Cold water faucet mixer tap	288
GD-MG	Hot/Cold water faucet mixer tap with auxiliary tap	326
GDPL-MG	Hot/Cold water faucet mixer tap elbow long lever, with auxiliary tap	344
GDB-2	Hot/Cold water faucet mixer tap with 1/4 swivel handles	244
GDM-MG	Wall hot/cold water faucet mixer tap with auxiliary tap	363

INDUSTRIAL TAPS

- Ergonomic long-lasting high quality taps for professional use.
- The different designs of the spouts and handles allow a solution for each necessity achieving an easy opening, regulation and closing.
- Manufactured of chromed brass of high density and thickness.



Model	Description	RRP (€)
GEB-M	Revolving low spout, mixer tap	98
GEB-2	Revolving low spout	95
GEM-M	Revolving mid-height spout, mixer tap	116
GEM-2	Revolving mid-height spout	76
GEA-M	Revolving high spout, mixer tap	127
GX-ML	Removable spout, long mixer tap	168

- They include flexible hose and all necessary accessories for its installation.
- The range comprises mixer tap models and ¼ swivel opening model.
- The taps with ¼ swivel handles and ceramic cartridge allow a quick simple opening.

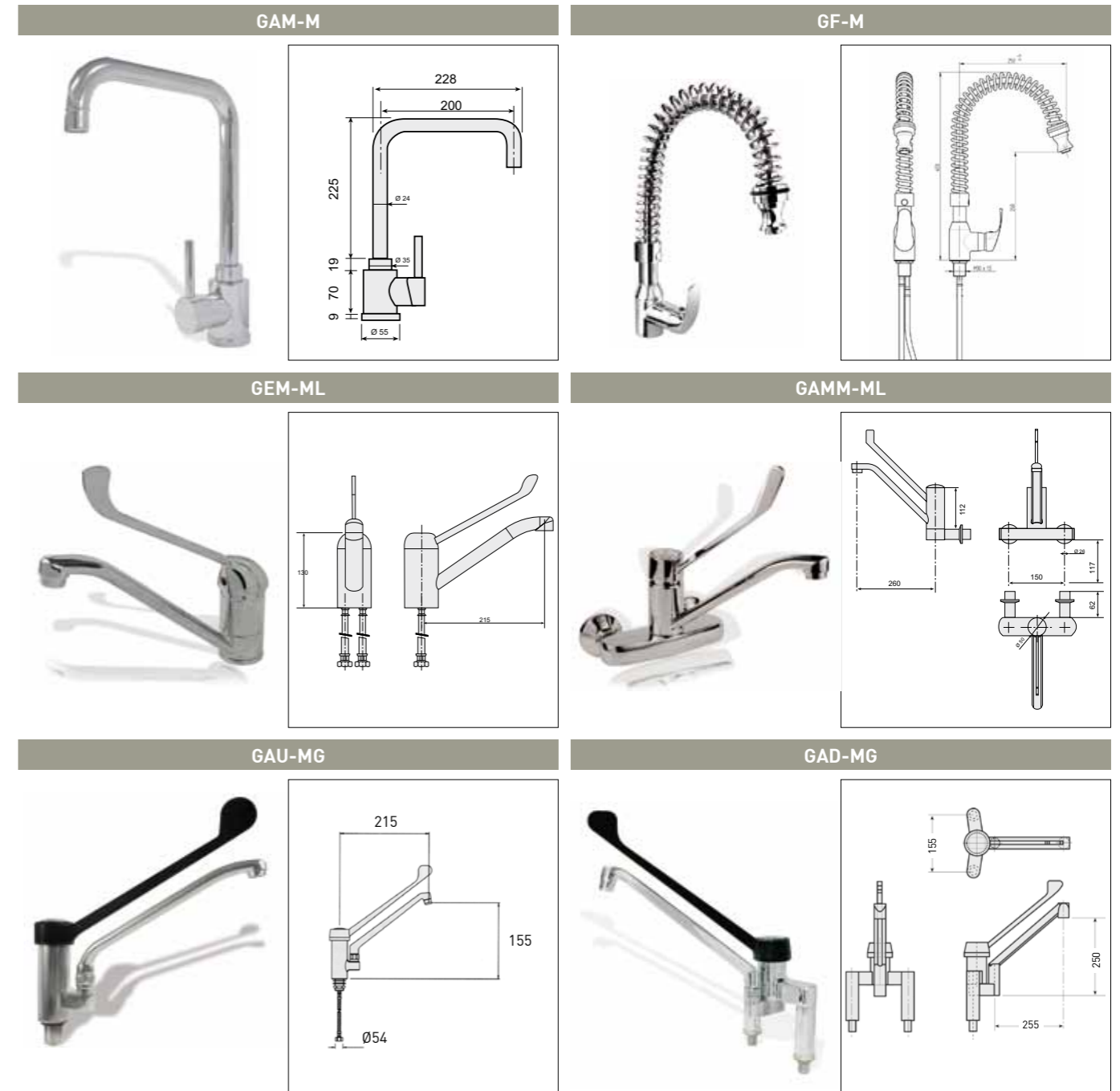

Model	Description	RRP (€)
GAM-M	High range revolving spout, mixer tap	168
GF-M	Flexible revolving spout, mixer tap	211
GEM-ML	Low spout, long mixer tap	101
GAMM-ML	Wall lower spout, long mixer tap	244
GAU-MG	Reinforced revolving spout, gerontologic tap	158
GAD-MG	Revolving spout, gerontologic tap	280

WORKING TABLES

Dismounted wall tables Range 600 and 700	page 40
Dismounted central tables Range 600 and 700	page 41
Dismounted wall tables Range 600 and 700	page 42
Dismounted central tables 600mm high Range 600 and 700	page 43
Dismounted wall tables with well Range 600 and 700	page 44
Shelves for tables	page 45
Table side splash and table side sheet	page 45
Welded wall tables Range 600 and 700	page 46
Welded central tables Range 600 and 700	page 47
Welded wall tables 600mm high Range 600 and 700	page 48
Welded central tables, 600mm high, range 600 and 700	page 49
Welded central tables with well range 600 and 700	page 50
Table shelves	page 51
Tables side splash and tables side sheets	page 51
Angled wall tables and countertops for corners	page 52
Wall stands	page 52
Tray slides body module	page 53
Drawers and chests of drawers with telescopic slides	page 53
Tabletop shelves	page 54
Lamp strips and heat lamp strips	page 55
Options for tables	page 55
Cutting wall tables	page 56
Cutting pylons	page 56
Gastronomy and bakery oven support tables	page 57
Cocktail stations	page 59
Countertop grilles	page 59

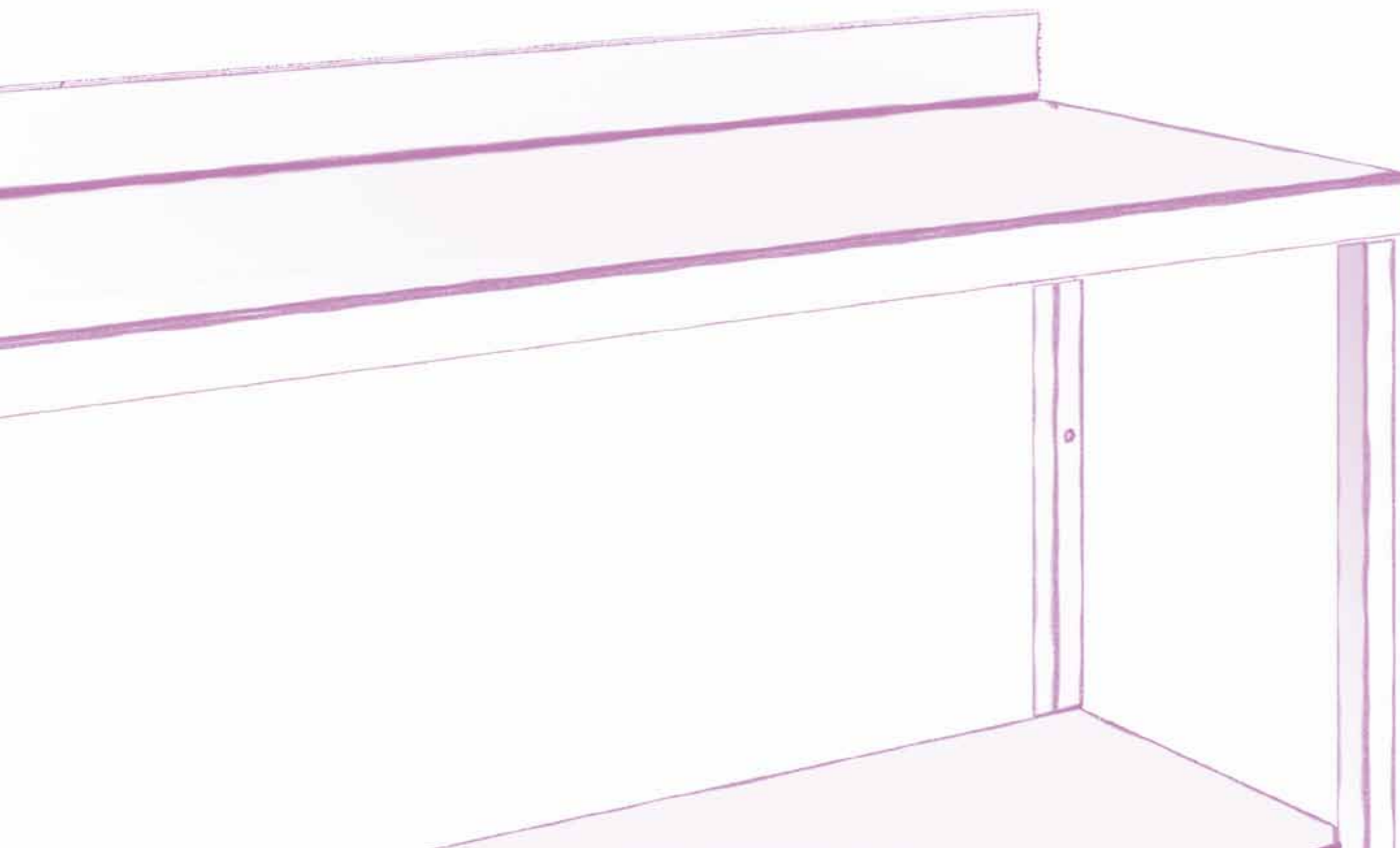

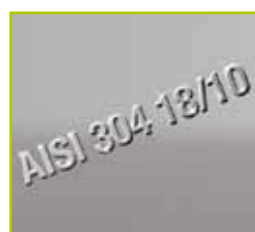

Maximum quality
Products manufactured of highest quality stainless steel AISI 304 18/10, designed with functional, elegant and uniform lines. Perfect, solid, hygienic finishes.



Countertops
They are very solid and completely welded tables with back-splash and sanitary rounded front edges. Soundproof countertops reinforced by highly thick omegas.



Dismounted models
Our dismantled models have been designed for a quick and easy assemble of the countertop, legs and shelves, and present a robust structure. They are supplied with screws and all necessary accessories.



Welded models
Countertops, legs and shelves utterly welded together to obtain a solid, stable and robust structure. Recessed 100mm back legs, height adjustable by means of unseen screws.



Uniform design
The uniform design of sinks, tables and all other products of our catalogue enables the combination of elements with total aesthetic and functional harmony, achieving elegant and practical compositions.



Wide range and availability
Our wide range of tables, together with the possibility of customized manufacturing, provides our clients with a solution adapted to each personal requirement. Our permanent stock ensures immediate delivery dates.



Options
Drawers, chests of drawers, slides modules, tabletop shelves, lam strips and heat lamp strips are all accessories that increase the tabletops functional possibilities.



Cocktail Stations
To our previous offer of cocktail stations, a vast range of new cocktail stations has been included.

DISMOUNTED MODELS

DISMOUNTED WALL TABLES RANGE 600 AND 700



Model with shelf

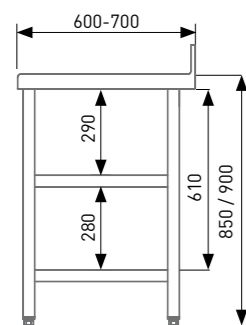

- Countertops manufactured of satin stainless steel AISI-304 18/10 with omegas reinforcement.
- Resistant structure, easy and quick to assemble by means of screws (key tool included).
- 100mm backsplash and 50mm rounded fronts, entirely welded.
- Legs manufactured of 40x40mm stainless steel tubes with adjustable feet by means of sanitary unseen screw.
- Tables without shelves, incorporate reinforcing 40x40mm tube providing excellent robustness.
- Optionally, an intermediate shelf can be supplied and added subsequently.
- They can be equipped with drawers, chests of drawers, slides modules, and tabletop shelves, among other accessories, see pages 51-55
- They are supplied dismounted.



Model with reinforcement

RANGE 600



Dimensions	WITH SHELF		WITH REINFORCEMENT	
	Model	RRP (€)	Model	RRP (€)
600x600x850	MMD60-60	361	MMSD60-60	354
700x600x850	MMD60-70	373	MMSD60-70	359
800x600x850	MMD60-80	381	MMSD60-80	362
900x600x850	MMD60-90	387	MMSD60-90	369
1000x600x850	MMD60-100	390	MMSD60-100	375
1100x600x850	MMD60-110	398	MMSD60-110	386
1200x600x850	MMD60-120	406	MMSD60-120	390
1300x600x850	MMD60-130	420	MMSD60-130	406
1400x600x850	MMD60-140	440	MMSD60-140	422
1500x600x850	MMD60-150	459	MMSD60-150	435
1600x600x850	MMD60-160	479	MMSD60-160	445
1700x600x850	MMD60-170	511	MMSD60-170	464
1800x600x850	MMD60-180	543	MMSD60-180	498
1900x600x850	MMD60-190	563	MMSD60-190	519
2000x600x850	MMD60-200	586	MMSD60-200	545
2200x600x850	MMD60-220	725	MMSD60-220	670
2400x600x850	MMD60-240	741	MMSD60-240	685

RANGE 700



Dimensions	WITH SHELF		WITH REINFORCEMENT	
	Model	RRP (€)	Model	RRP (€)
600x700x850	MMD70-60	367	MMSD70-60	358
700x700x850	MMD70-70	382	MMSD70-70	360
800x700x850	MMD70-80	393	MMSD70-80	366
900x700x850	MMD70-90	406	MMSD70-90	383
1000x700x850	MMD70-100	423	MMSD70-100	403
1100x700x850	MMD70-110	433	MMSD70-110	414
1200x700x850	MMD70-120	444	MMSD70-120	428
1300x700x850	MMD70-130	469	MMSD70-130	444
1400x700x850	MMD70-140	493	MMSD70-140	470
1500x700x850	MMD70-150	511	MMSD70-150	482
1600x700x850	MMD70-160	526	MMSD70-160	488
1700x700x850	MMD70-170	561	MMSD70-170	492
1800x700x850	MMD70-180	593	MMSD70-180	532
1900x700x850	MMD70-190	620	MMSD70-190	572
2000x700x850	MMD70-200	649	MMSD70-200	605
2200x700x850	MMD70-220	756	MMSD70-220	721
2400x700x850	MMD70-240	778	MMSD70-240	749

DISMOUNTED CENTRAL TABLES RANGE 600 AND 700

DISMOUNTED MODELS

- Countertops manufactured of satin stainless steel AISI-304 18/10 with omegas reinforcement.
- Resistant structure, easy and quick to assemble by means of screws (key tool included).
- 50mm rounded fronts, entirely welded.
- Tables without shelves, incorporate reinforcing 40x40mm tube providing excellent robustness.
- Legs manufactured of 40x40mm stainless steel tubes with adjustable feet by means of sanitary unseen screw.
- Optionally, an intermediate shelf can be supplied and added subsequently.
- Stainless steel AISI-304 18/10 embedded wells with soundproof cover, drainage valve and spillway tube.
- They can be equipped with drawers, chests of drawers, slide modules, and tabletop shelves, among other accessories, see pages 51-55
- They are supplied dismounted.



Model with shelf

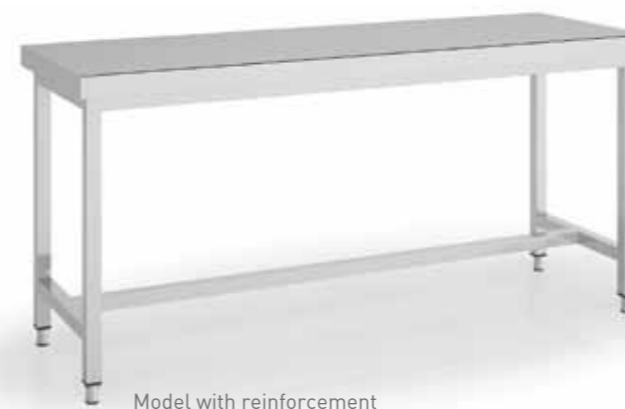

Model with reinforcement

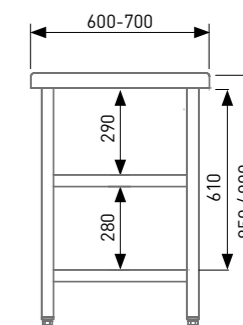

RANGE 600



Dimensions	WITH SHELF		WITH REINFORCEMENT	
	Model	RRP (€)	Model	RRP (€)
600x600x850	MCD60-60	359	MCSD60-60	348
700x600x850	MCD60-70	365	MCSD60-70	350
800x600x850	MCD60-80	373	MCSD60-80	356
900x600x850	MCD60-90	379	MCSD60-90	360
1000x600x850	MCD60-100	385	MCSD60-100	364
1100x600x850	MCD60-110	388	MCSD60-110	371
1200x600x850	MCD60-120	394	MCSD60-120	379
1300x600x850	MCD60-130	411	MCSD60-130	396
1400x600x850	MCD60-140	434	MCSD60-140	410
1500x600x850	MCD60-150	450	MCSD60-150	417
1600x600x850	MCD60-160	465	MCSD60-160	435
1700x600x850	MCD60-170	498	MCSD60-170	450
1800x600x850	MCD60-180	532	MCSD60-180	481
1900x600x850	MCD60-190	548	MCSD60-190	488
2000x600x850	MCD60-200	562	MCSD60-200	509
2200x600x850	MCD60-220	658	MCSD60-220	634
2400x600x850	MCD60-240	676	MCSD60-240	645

RANGE 700



Dimensions	WITH SHELF		WITH REINFORCEMENT	
	Model	RRP (€)	Model	RRP (€)
600x700x850	MCD70-60	364	MCSD70-60	344
700x700x850	MCD70-70	372	MCSD70-70	348
800x700x850	MCD70-80	384	MCSD70-80	356
900x700x850	MCD70-90	390	MCSD70-90	366
1000x700x850	MCD70-100	406	MCSD70-100	380
1100x700x850	MCD70-110	410	MCSD70-110	388
1200x700x850	MCD70-120	419	MCSD70-120	391
1300x700x850	MCD70-130	448	MCSD70-130	419
1400x700x850	MCD70-140	486	MCSD70-140	444
1500x700x850	MCD70-150	494	MCSD70-150	452
1600x700x850	MCD70-160	503	MCSD70-160	459
1700x700x850	MCD70-170	542	MCSD70-170	482
1800x700x850	MCD70-180	581	MCSD70-180	514
1900x700x850	MCD70-190	597	MCSD70-190	535
2000x700x850	MCD70-200	608	MCSD70-200	561
2200x700x850	MCD70-220	685	MCSD70-220	650
2400x700x850	MCD70-240	712	MCSD70-240	703

DISMOUNTED MODELS

DISMOUNTED WALL TABLES, 600mm HIGH RANGE 600 and 700



Model with shelf

- Countertops manufactured of satin stainless steel AISI-304 18/10 with omegas reinforcement.
- Resistant structure, easy and quick to assemble by means of screws (key tool included).
- 100mm backsplash and 50mm rounded fronts, entirely welded.
- Legs manufactured of 40x40mm stainless steel tubes with adjustable feet by means of sanitary unseen screw.
- Tables without shelves, incorporate reinforcing 40x40mm tube providing excellent robustness.
- They are supplied dismounted.



Model with reinforcement

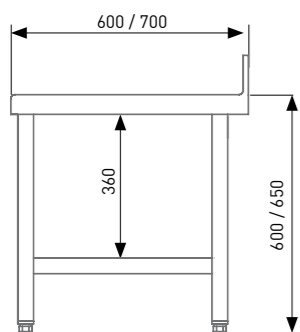

DISMOUNTED CENTRAL TABLES 600m HIGH RANGE 600 AND 700

DISMOUNTED MODELS

- Countertops manufactured of satin stainless steel AISI-304 18/10 with omegas reinforcement.
- Resistant structure, easy and quick to assemble by means of screws (key tool included).
- 50mm rounded fronts, entirely welded.
- Legs manufactured of 40x40mm stainless steel tubes with adjustable feet by means of sanitary unseen screw.
- On tables without shelves, reinforcing 40x40mm tube is added providing excellent robustness.
- They are supplied dismounted.



Model with shelf



Model with reinforcement

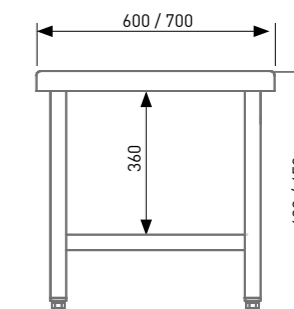

RANGE 600



Dimensions	WITH SHELF		WITH REINFORCEMENT	
	Model	RRP(€)	Model	RRP(€)
600x600x600	MMBD60-60	361	MMSBD60-60	354
700x600x600	MMBD60-70	373	MMSBD60-70	359
800x600x600	MMBD60-80	381	MMSBD60-80	362
900x600x600	MMBD60-90	387	MMSBD60-90	369
1000x600x600	MMBD60-100	390	MMSBD60-100	375
1100x600x600	MMBD60-110	398	MMSBD60-110	386
1200x600x600	MMBD60-120	406	MMSBD60-120	390
1300x600x600	MMBD60-130	420	MMSBD60-130	406
1400x600x600	MMBD60-140	440	MMSBD60-140	422
1500x600x600	MMBD60-150	459	MMSBD60-150	435
1600x600x600	MMBD60-160	479	MMSBD60-160	445
1700x600x600	MMBD60-170	511	MMSBD60-170	464
1800x600x600	MMBD60-180	543	MMSBD60-180	498
1900x600x600	MMBD60-190	563	MMSBD60-190	519
2000x600x600	MMBD60-200	586	MMSBD60-200	545
2200x600x600	MMBD60-220	725	MMSBD60-220	670
2400x600x600	MMBD60-240	741	MMSBD60-240	685

RANGE 700



Dimensions	WITH SHELF		WITH REINFORCEMENT	
	Model	RRP(€)	Model	RRP(€)
600x700x600	MMBD70-60	367	MMSBD70-60	358
700x700x600	MMBD70-70	382	MMSBD70-70	360
800x700x600	MMBD70-80	393	MMSBD70-80	366
900x700x600	MMBD70-90	406	MMSBD70-90	383
1000x700x600	MMBD70-100	423	MMSBD70-100	403
1100x700x600	MMBD70-110	433	MMSBD70-110	414
1200x700x600	MMBD70-120	444	MMSBD70-120	428
1300x700x600	MMBD70-130	469	MMSBD70-130	444
1400x700x600	MMBD70-140	493	MMSBD70-140	470
1500x700x600	MMBD70-150	511	MMSBD70-150	482
1600x700x600	MMBD70-160	526	MMSBD70-160	488
1700x700x600	MMBD70-170	561	MMSBD70-170	492
1800x700x600	MMBD70-180	593	MMSBD70-180	532
1900x700x600	MMBD70-190	620	MMSBD70-190	572
2000x700x600	MMBD70-200	649	MMSBD70-200	605
2200x700x600	MMBD70-220	756	MMSBD70-220	721
2400x700x600	MMBD70-240	778	MMSBD70-240	749

RANGE 600



Dimensions	WITH SHELF		WITH REINFORCEMENT	
	Model	RRP(€)	Model	RRP(€)
600x600x600	MCBD60-60	359	MCSBD60-60	348
700x600x600	MCBD60-70	365	MCSBD60-70	350
800x600x600	MCBD60-80	373	MCSBD60-80	356
900x600x600	MCBD60-90	379	MCSBD60-90	360
1000x600x600	MCBD60-100	385	MCSBD60-100	364
1100x600x600	MCBD60-110	388	MCSBD60-110	371
1200x600x600	MCBD60-120	394	MCSBD60-120	379
1300x600x600	MCBD60-130	411	MCSBD60-130	396
1400x600x600	MCBD60-140	434	MCSBD60-140	410
1500x600x600	MCBD60-150	450	MCSBD60-150	417
1600x600x600	MCBD60-160	465	MCSBD60-160	435
1700x600x600	MCBD60-170	498	MCSBD60-170	450
1800x600x600	MCBD60-180	532	MCSBD60-180	481
1900x600x600	MCBD60-190	548	MCSBD60-190	488
2000x600x600	MCBD60-200	562	MCSBD60-200	509
2200x600x600	MCBD60-220	658	MCSBD60-220	634
2400x600x600	MCBD60-240	676	MCSBD60-240	645

RANGE 700



Dimensions	WITH SHELF		WITH REINFORCEMENT	
	Model	RRP(€)	Model	RRP(€)
600x700x600	MCBD70-60	364	MCSBD70-60	344
700x700x600	MCBD70-70	372	MCSBD70-70	348
800x700x600	MCBD70-80	384	MCSBD70-80	356
900x700x600	MCBD70-90	390	MCSBD70-90	366
1000x700x600	MCBD70-100	406	MCSBD70-100	380
1100x700x600	MCBD70-110	410	MCSBD70-110	388
1200x700x600	MCBD70-120	419	MCSBD70-120	391
1300x700x600	MCBD70-130	448	MCSBD70-130	419
1400x700x600	MCBD70-140	486	MCSBD70-140	444
1500x700x600	MCBD70-150	494	MCSBD70-150	452
1600x700x600	MCBD70-160	503	MCSBD70-160	459
1700x700x600	MCBD70-170	542	MCSBD70-170	482
1800x700x600	MCBD70-180	581	MCSBD70-180	514
1900x700x600	MCBD70-190	597	MCSBD70-190	535
2000x700x600	MCBD70-200	608	MCSBD70-200	561
2200x700x600	MCBD70-220	685	MCSBD70-220	650
2400x700x600	MCBD70-240	712	MCSBD70-240	703

DISMOUNTED MODELS

DISMOUNTED WALL TABLES WITH WELL RANGE 600 AND 700



- Countertops manufactured of satin stainless steel AISI-304 18/10 with omegas reinforcement.
- Resistant structure, easy and quick to assemble by means of screws (key tool included).
- 100mm backsplash and 50mm rounded fronts, entirely welded.
- Well with drainage and soundproof cover, 400x400x200mm.
- Tables without shelves, incorporate reinforcing 40x40mm tube providing excellent robustness.
- Legs manufactured of 40x40mm stainless steel tubes with adjustable feet by means of sanitary unseen screw.
- On the countertop a Ø35mm tap fitting bore is added.
- They are supplied dismantled.

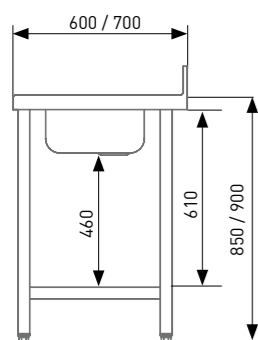

TABLE WITH SHELF



TABLE WITH REINFORCEMENT

	Dimensions	TABLE WITH SHELF			RRP (€)	TABLE WITH REINFORCEMENT			RRP (€)
		Right well	Central well	Left well		Right well	Central well	Left well	
600	1000x600x600	MCCD60-100DE	MCCD60-100CE	MCCD60-100IE	581	MCCD60-100D	MCCD60-100C	MCCD60-100I	566
	1200x600x600	MCCD60-120DE	MCCD60-120CE	MCCD60-120IE	597	MCCD60-120D	MCCD60-120C	MCCD60-120I	581
	1400x600x600	MCCD60-140DE	MCCD60-140CE	MCCD60-140IE	631	MCCD60-140D	MCCD60-140C	MCCD60-140I	613
	1500x600x600	MCCD60-150DE	MCCD60-150CE	MCCD60-150IE	650	MCCD60-150D	MCCD60-150C	MCCD60-150I	626
	1600x600x600	MCCD60-160DE	MCCD60-160CE	MCCD60-160IE	670	MCCD60-160D	MCCD60-160C	MCCD60-160I	636
	1800x600x600	MCCD60-180DE	MCCD60-180CE	MCCD60-180IE	734	MCCD60-180D	MCCD60-180C	MCCD60-180I	689
	2000x600x600	MCCD60-200DE	MCCD60-200CE	MCCD60-200IE	777	MCCD60-200D	MCCD60-200C	MCCD60-200I	736
	2200x600x600	MCCD60-220DE	MCCD60-220CE	MCCD60-220IE	916	MCCD60-220D	MCCD60-220C	MCCD60-220I	861
2400x600x600	MCCD60-240DE	MCCD60-240CE	MCCD60-240IE	932	MCCD60-240D	MCCD60-240C	MCCD60-240I	876	
700	1000x700x850	MCCD70-100DE	MCCD70-100CE	MCCD70-100IE	614	MCCD70-100D	MCCD70-100C	MCCD70-100I	594
	1200x700x850	MCCD70-120DE	MCCD70-120CE	MCCD70-120IE	635	MCCD70-120D	MCCD70-120C	MCCD70-120I	619
	1400x700x850	MCCD70-140DE	MCCD70-140CE	MCCD70-140IE	684	MCCD70-140D	MCCD70-140C	MCCD70-140I	661
	1500x700x850	MCCD70-150DE	MCCD70-150CE	MCCD70-150IE	702	MCCD70-150D	MCCD70-150C	MCCD70-150I	673
	1600x700x850	MCCD70-160DE	MCCD70-160CE	MCCD70-160IE	717	MCCD70-160D	MCCD70-160C	MCCD70-160I	679
	1800x700x850	MCCD70-180DE	MCCD70-180CE	MCCD70-180IE	784	MCCD70-180D	MCCD70-180C	MCCD70-180I	723
	2000x700x850	MCCD70-200DE	MCCD70-200CE	MCCD70-200IE	840	MCCD70-200D	MCCD70-200C	MCCD70-200I	796
	2200x700x850	MCCD70-220DE	MCCD70-220CE	MCCD70-220IE	947	MCCD70-220D	MCCD70-220C	MCCD70-220I	912
2400x700x850	MCCD70-240DE	MCCD70-240CE	MCCD70-240IE	969	MCCD70-240D	MCCD70-240C	MCCD70-240I	940	

SHELVES FOR TABLES RANGE

- Shelves for all the tables range.
- Manufactured of satin stainless steel AISI-304 18/10 with 40mm front and omegas reinforcement.
- Easy to assemble by means of supplied screws (included).

RANGE 600			RANGE 700		
Model	For tables	RRP (€)	Model	For tables	RRP (€)
EB-66	600x600	85	EB-67	600x700	89
EB-76	700x600	92	EB-77	700x700	100
EB-86	800x600	102	EB-87	800x700	114
EB-96	900x600	111	EB-97	900x700	121
EB-106	1000x600	121	EB-107	1000x700	130
EB-116	1100x600	127	EB-117	1100x700	136
EB-126	1200x600	133	EB-127	1200x700	152
EB-136	1300x600	144	EB-137	1300x700	161
EB-146	1400x600	157	EB-147	1400x700	169
EB-156	1500x600	164	EB-157	1500x700	180
EB-166	1600x600	171	EB-167	1600x700	202
EB-176	1700x600	185	EB-177	1700x700	210
EB-186	1800x600	198	EB-187	1800x700	216
EB-196	1900x600	203	EB-197	1900x700	219
EB-206	2000x600	207	EB-207	2000x700	223
EB-226	2200x600	213	EB-227	2200x700	229
EB-246	2400x600	232	EB-247	2400x700	246



TABLE SIDE SPLASH

- Manufactured of satin stainless steel AISI-304 18/10.
- It can be fitted on any ERATOS countertop or sink top.
- Easy to assemble.

Model	Side splash	Range	RRP (€)
PL-60D	Right	600	101
PL-60I	Left	600	101
PL-70D	Right	700	109
PL-70I	Left	700	109



TABLE SIDE SHEET

- Manufactured of satin stainless steel AISI-304 18/10.
- It can be fitted on any ERATOS table frame work.

Model	Range	RRP (€)
PLM-60	600	104
PLM-70	700	108



WELDED MODELS

WELDED WALL TABLES RANGE 600 AND 700



Model with shelf

- Countertops manufactured of satin stainless steel AISI-304 18/10 with omegas reinforcement.
- Utterly welded structure.
- 100mm backsplash and 50mm rounded fronts, entirely welded.
- Tables without shelves, incorporate reinforcing 40x40mm tube providing excellent robustness.
- Legs manufactured of 40x40mm stainless steel tubes with adjustable feet by means of sanitary unseen screw.
- Optionally, an additional intermediate shelf can be added, which must be integrated and welded in ERATOS premises.
- They can be equipped with drawers, chests of drawers, slides modules, and tabletop shelves, among other accessories, see pages 51-55



Model with reinforcement

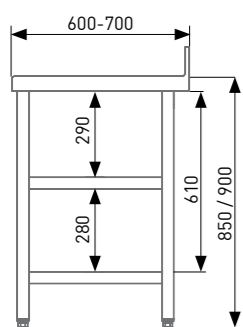

WELDED CENTRAL TABLES RANGE 600 AND 700

WELDED MODELS

- Countertops manufactured of satin stainless steel AISI-304 18/10 with omegas reinforcement.
- Utterly welded structure.
- 50mm rounded fronts, entirely welded.
- Tables without shelves, incorporate reinforcing 40x40mm tube providing excellent robustness.
- Legs manufactured of 40x40mm stainless steel tubes with adjustable feet by means of sanitary unseen screw.
- Optionally, an additional intermediate shelf can be added, which must be integrated and welded in ERATOS premises.
- They can be equipped with drawers, chests of drawers, slides modules, and tabletop shelves, among other accessories, see pages 51-55



Model with shelf

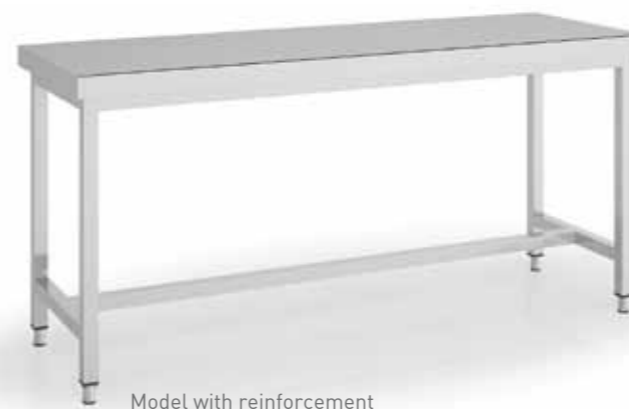

Model with reinforcement

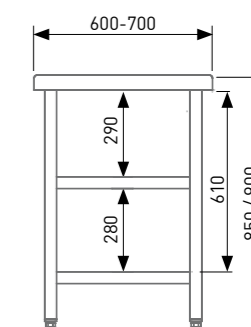

RANGE 600



Dimensions	WITH SHELF		WITH REINFORCEMENT	
	Model	RRP(€)	Model	RRP(€)
600x600x850	MM60-60	400	MMS60-60	393
700x600x850	MM60-70	412	MMS60-70	398
800x600x850	MM60-80	420	MMS60-80	401
900x600x850	MM60-90	426	MMS60-90	408
1000x600x850	MM60-100	429	MMS60-100	414
1100x600x850	MM60-110	437	MMS60-110	425
1200x600x850	MM60-120	460	MMS60-120	444
1300x600x850	MM60-130	474	MMS60-130	460
1400x600x850	MM60-140	494	MMS60-140	476
1500x600x850	MM60-150	515	MMS60-150	491
1600x600x850	MM60-160	535	MMS60-160	501
1700x600x850	MM60-170	567	MMS60-170	520
1800x600x850	MM60-180	599	MMS60-180	554
1900x600x850	MM60-190	619	MMS60-190	575
2000x600x850	MM60-200	663	MMS60-200	622
2200x600x850	MM60-220	802	MMS60-220	747
2400x600x850	MM60-240	818	MMS60-240	762

RANGE 700



Dimensions	WITH SHELF		WITH REINFORCEMENT	
	Model	RRP(€)	Model	RRP(€)
600x700x850	MM70-60	406	MMS70-60	397
700x700x850	MM70-70	421	MMS70-70	399
800x700x850	MM70-80	432	MMS70-80	405
900x700x850	MM70-90	445	MMS70-90	422
1000x700x850	MM70-100	462	MMS70-100	442
1100x700x850	MM70-110	472	MMS70-110	453
1200x700x850	MM70-120	499	MMS70-120	483
1300x700x850	MM70-130	524	MMS70-130	499
1400x700x850	MM70-140	548	MMS70-140	525
1500x700x850	MM70-150	569	MMS70-150	540
1600x700x850	MM70-160	584	MMS70-160	546
1700x700x850	MM70-170	619	MMS70-170	550
1800x700x850	MM70-180	651	MMS70-180	590
1900x700x850	MM70-190	678	MMS70-190	630
2000x700x850	MM70-200	710	MMS70-200	666
2200x700x850	MM70-220	817	MMS70-220	782
2400x700x850	MM70-240	839	MMS70-240	810

RANGE 600

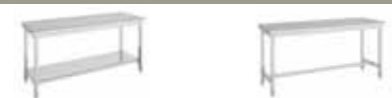

Dimensions	WITH SHELF		WITH REINFORCEMENT	
	Model	RRP(€)	Model	RRP(€)
600x600x850	MC60-60	398	MCS60-60	387
700x600x850	MC60-70	404	MCS60-70	389
800x600x850	MC60-80	412	MCS60-80	395
900x600x850	MC60-90	418	MCS60-90	399
1000x600x850	MC60-100	424	MCS60-100	403
1100x600x850	MC60-110	427	MCS60-110	410
1200x600x850	MC60-120	448	MCS60-120	433
1300x600x850	MC60-130	465	MCS60-130	450
1400x600x850	MC60-140	488	MCS60-140	464
1500x600x850	MC60-150	506	MCS60-150	473
1600x600x850	MC60-160	521	MCS60-160	491
1700x600x850	MC60-170	554	MCS60-170	506
1800x600x850	MC60-180	588	MCS60-180	537
1900x600x850	MC60-190	604	MCS60-190	544
2000x600x850	MC60-200	639	MCS60-200	586
2200x600x850	MC60-220	735	MCS60-220	711
2400x600x850	MC60-240	753	MCS60-240	722

RANGE 700



Dimensions	WITH SHELF		WITH REINFORCEMENT	
	Model	RRP(€)	Model	RRP(€)
600x700x850	MC70-60	403	MCS70-60	383
700x700x850	MC70-70	411	MCS70-70	387
800x700x850	MC70-80	423	MCS70-80	395
900x700x850	MC70-90	429	MCS70-90	405
1000x700x850	MC70-100	445	MCS70-100	419
1100x700x850	MC70-110	449	MCS70-110	427
1200x700x850	MC70-120	474	MCS70-120	446
1300x700x850	MC70-130	503	MCS70-130	474
1400x700x850	MC70-140	541	MCS70-140	499
1500x700x850	MC70-150	552	MCS70-150	510
1600x700x850	MC70-160	561	MCS70-160	517
1700x700x850	MC70-170	600	MCS70-170	540
1800x700x850	MC70-180	639	MCS70-180	572
1900x700x850	MC70-190	655	MCS70-190	593
2000x700x850	MC70-200	669	MCS70-200	622
2200x700x850	MC70-220	746	MCS70-220	711
2400x700x850	MC70-240	773	MCS70-240	764

WELDED MODELS

WELDED WALL TABLES RANGE 600 AND 700



Model with shelf

- Countertops manufactured of satin stainless steel AISI-304 18/10 with omegas reinforcement.
- Utterly welded structure.
- 100mm backsplash and 50mm rounded fronts, entirely welded.
- Tables without shelves incorporate reinforcing 40x40mm tube providing excellent robustness.
- Legs manufactured of 40x40mm stainless steel tubes with adjustable feet by means of sanitary unseen screw.



Model with reinforcement

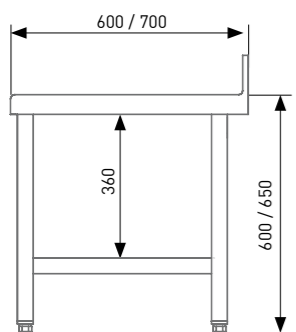

WELDED CENTRAL TABLES, 600mm HIGH, RANGE 600 AND 700

WELDED MODELS

- Countertops manufactured of satin stainless steel AISI-304 18/10 with omegas reinforcement.
- Utterly welded structure.
- 50mm rounded fronts, and entirely welded.
- Tables without shelves incorporate reinforcing 40x40mm tube providing excellent robustness.
- Legs manufactured of 40x40mm stainless steel tubes with adjustable feet by means of sanitary unseen screw.



Model with shelf



Model with reinforcement

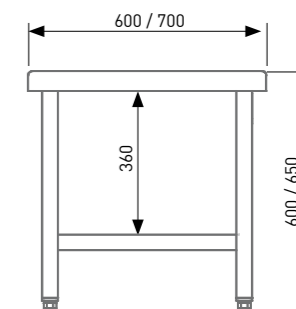

RANGE 600



Dimensions	WITH SHELF		WITH REINFORCEMENT	
	Model	RRP(€)	Model	RRP(€)
600x600x600	MMB60-60	400	MMSB60-60	393
700x600x600	MMB60-70	412	MMSB60-70	398
800x600x600	MMB60-80	420	MMSB60-80	401
900x600x600	MMB60-90	426	MMSB60-90	408
1000x600x600	MMB60-100	429	MMSB60-100	414
1100x600x600	MMB60-110	437	MMSB60-110	425
1200x600x600	MMB60-120	460	MMSB60-120	444
1300x600x600	MMB60-130	474	MMSB60-130	460
1400x600x600	MMB60-140	494	MMSB60-140	476
1500x600x600	MMB60-150	515	MMSB60-150	491
1600x600x600	MMB60-160	535	MMSB60-160	501
1700x600x600	MMB60-170	567	MMSB60-170	520
1800x600x600	MMB60-180	599	MMSB60-180	554
1900x600x600	MMB60-190	619	MMSB60-190	575
2000x600x600	MMB60-200	663	MMSB60-200	622
2200x600x600	MMB60-220	802	MMSB60-220	747
2400x600x600	MMB60-240	818	MMSB60-240	762

RANGE 700



Dimensions	WITH SHELF		WITH REINFORCEMENT	
	Model	RRP(€)	Model	RRP(€)
600x700x600	MMB70-60	406	MMSB70-60	397
700x700x600	MMB70-70	421	MMSB70-70	399
800x700x600	MMB70-80	432	MMSB70-80	405
900x700x600	MMB70-90	445	MMSB70-90	422
1000x700x600	MMB70-100	462	MMSB70-100	442
1100x700x600	MMB70-110	472	MMSB70-110	453
1200x700x600	MMB70-120	499	MMSB70-120	483
1300x700x600	MMB70-130	524	MMSB70-130	499
1400x700x600	MMB70-140	548	MMSB70-140	525
1500x700x600	MMB70-150	569	MMSB70-150	540
1600x700x600	MMB70-160	584	MMSB70-160	546
1700x700x600	MMB70-170	619	MMSB70-170	550
1800x700x600	MMB70-180	651	MMSB70-180	590
1900x700x600	MMB70-190	678	MMSB70-190	630
2000x700x600	MMB70-200	710	MMSB70-200	666
2200x700x600	MMB70-220	817	MMSB70-220	782
2400x700x600	MMB70-240	839	MMSB70-240	810

RANGE 600



Dimensions	WITH SHELF		WITH REINFORCEMENT	
	Model	RRP(€)	Model	RRP(€)
600x600x600	MCB60-60	398	MCSB60-60	387
700x600x600	MCB60-70	404	MCSB60-70	389
800x600x600	MCB60-80	412	MCSB60-80	395
900x600x600	MCB60-90	418	MCSB60-90	399
1000x600x600	MCB60-100	424	MCSB60-100	403
1100x600x600	MCB60-110	427	MCSB60-110	410
1200x600x600	MCB60-120	448	MCSB60-120	433
1300x600x600	MCB60-130	465	MCSB60-130	450
1400x600x600	MCB60-140	488	MCSB60-140	464
1500x600x600	MCB60-150	506	MCSB60-150	473
1600x600x600	MCB60-160	521	MCSB60-160	491
1700x600x600	MCB60-170	554	MCSB60-170	506
1800x600x600	MCB60-180	588	MCSB60-180	537
1900x600x600	MCB60-190	604	MCSB60-190	544
2000x600x600	MCB60-200	639	MCSB60-200	586
2200x600x600	MCB60-220	735	MCSB60-220	711
2400x600x600	MCB60-240	753	MCSB60-240	722

RANGE 700



Dimensions	WITH SHELF		WITH REINFORCEMENT	
	Model	RRP(€)	Model	RRP(€)
600x700x600	MCB70-60	403	MCSB70-60	383
700x700x600	MCB70-70	411	MCSB70-70	387
800x700x600	MCB70-80	423	MCSB70-80	395
900x700x600	MCB70-90	429	MCSB70-90	405
1000x700x600	MCB70-100	445	MCSB70-100	419
1100x700x600	MCB70-110	449	MCSB70-110	427
1200x700x600	MCB70-120	474	MCSB70-120	446
1300x700x600	MCB70-130	503	MCSB70-130	474
1400x700x600	MCB70-140	541	MCSB70-140	499
1500x700x600	MCB70-150	552	MCSB70-150	510
1600x700x600	MCB70-160	561	MCSB70-160	517
1700x700x600	MCB70-170	600	MCSB70-170	540
1800x700x600	MCB70-180	639	MCSB70-180	572
1900x700x600	MCB70-190	655	MCSB70-190	593
2000x700x600	MCB70-200	669	MCSB70-200	622
2200x700x600	MCB70-220	746	MCSB70-220	711
2400x700x600	MCB70-240	773	MCSB70-240	764

WELDED MODELS

WELDED CENTRAL TABLES WITH WELL RANGE 600 AND 700



- Countertops manufactured of satin stainless steel AISI-304 18/10 with omegas reinforcement.
- Utterly welded structure.
- 100mm backsplash and 50mm rounded fronts, entirely welded.
- Well with drainage and soundproof cover, 400x400x250mm.
- Tables without shelves incorporate reinforcing 40x40mm tube providing excellent robustness.
- Legs manufactured of 40x40mm stainless steel tubes with height adjustable feet by means of sanitary unseen screw.
- On the countertop a Ø37mm tap fitting bore is added.

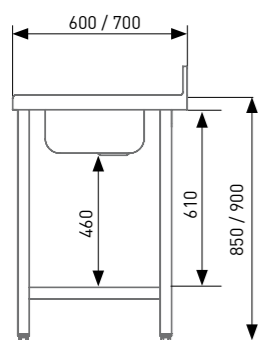

TABLE WITH SHELF



TABLE WITH REINFORCEMENT

Dimensions	TABLE WITH SHELF				TABLE WITH REINFORCEMENT				
	Right well	Central well	Left well	RRP (€)	Right well	Central well	Left well	RRP (€)	
600	1000x600x600	MCC60-100DE	MCC60-100CE	MCC60-100IE	620	MCC60-100D	MCC60-100C	MCC60-100I	605
	1200x600x600	MCC60-120DE	MCC60-120CE	MCC60-120IE	651	MCC60-120D	MCC60-120C	MCC60-120I	635
	1400x600x600	MCC60-140DE	MCC60-140CE	MCC60-140IE	685	MCC60-140D	MCC60-140C	MCC60-140I	667
	1500x600x600	MCC60-150DE	MCC60-150CE	MCC60-150IE	706	MCC60-150D	MCC60-150C	MCC60-150I	682
	1600x600x600	MCC60-160DE	MCC60-160CE	MCC60-160IE	726	MCC60-160D	MCC60-160C	MCC60-160I	692
	1800x600x600	MCC60-180DE	MCC60-180CE	MCC60-180IE	790	MCC60-180D	MCC60-180C	MCC60-180I	745
	2000x600x600	MCC60-200DE	MCC60-200CE	MCC60-200IE	854	MCC60-200D	MCC60-200C	MCC60-200I	813
	2200x600x600	MCC60-220DE	MCC60-220CE	MCC60-220IE	993	MCC60-220D	MCC60-220C	MCC60-220I	938
	2400x600x600	MCC60-240DE	MCC60-240CE	MCC60-240IE	1009	MCC60-240D	MCC60-240C	MCC60-240I	953
700	1000x700x850	MCC70-100DE	MCC70-100CE	MCC70-100IE	653	MCC70-100D	MCC70-100C	MCC70-100I	633
	1200x700x850	MCC70-120DE	MCC70-120CE	MCC70-120IE	690	MCC70-120D	MCC70-120C	MCC70-120I	674
	1400x700x850	MCC70-140DE	MCC70-140CE	MCC70-140IE	739	MCC70-140D	MCC70-140C	MCC70-140I	716
	1500x700x850	MCC70-150DE	MCC70-150CE	MCC70-150IE	760	MCC70-150D	MCC70-150C	MCC70-150I	731
	1600x700x850	MCC70-160DE	MCC70-160CE	MCC70-160IE	775	MCC70-160D	MCC70-160C	MCC70-160I	737
	1800x700x850	MCC70-180DE	MCC70-180CE	MCC70-180IE	842	MCC70-180D	MCC70-180C	MCC70-180I	781
	2000x700x850	MCC70-200DE	MCC70-200CE	MCC70-200IE	901	MCC70-200D	MCC70-200C	MCC70-200I	857
	2200x700x850	MCC70-220DE	MCC70-220CE	MCC70-220IE	1008	MCC70-220D	MCC70-220C	MCC70-220I	973
	2400x700x850	MCC70-240DE	MCC70-240CE	MCC70-240IE	1030	MCC70-240D	MCC70-240C	MCC70-240I	1001

SHELVES FOR TABLES RANGE

- Shelves for all the tables range.
- Manufactured of satin stainless steel AISI-304 18/10 with 40mm front and omegas reinforcement.
- Easy to assemble by means of supplied screws (included).

RANGE 600			RANGE 700		
Model	For tables	RRP (€)	Model	For tables	RRP (€)
EB-66	600x600	85	EB-67	600x700	89
EB-76	700x600	92	EB-77	700x700	100
EB-86	800x600	102	EB-87	800x700	114
EB-96	900x600	111	EB-97	900x700	121
EB-106	1000x600	121	EB-107	1000x700	130
EB-116	1100x600	127	EB-117	1100x700	136
EB-126	1200x600	133	EB-127	1200x700	152
EB-136	1300x600	144	EB-137	1300x700	161
EB-146	1400x600	157	EB-147	1400x700	169
EB-156	1500x600	164	EB-157	1500x700	180
EB-166	1600x600	171	EB-167	1600x700	202
EB-176	1700x600	185	EB-177	1700x700	210
EB-186	1800x600	198	EB-187	1800x700	216
EB-196	1900x600	203	EB-197	1900x700	219
EB-206	2000x600	207	EB-207	2000x700	223
EB-226	2200x600	213	EB-227	2200x700	229
EB-246	2400x600	232	EB-247	2400x700	246



TABLE SIDE SPLASH

- Manufactured of satin stainless steel AISI-304 18/10.
- It can be fitted on any ERATOS countertop or sink top.
- Easy to assemble.

Model	Side splash	Range	RRP (€)
PL-60D	Right	600	101
PL-60I	Left	600	101
PL-70D	Right	700	109
PL-70I	Left	700	109



TABLE SIDE SHEET

- Manufactured of satin stainless steel AISI-304 18/10.
- It can be fitted on any ERATOS table frame work.

Model	Range	RRP (€)
PLM-60	600	104
PLM-70	700	108





Model MMRD-67

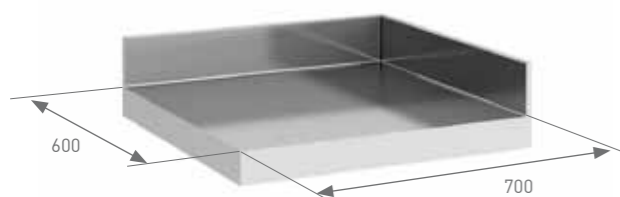

Model ER-67



Model ERC-67



Mod. SM

Mod. SMP

Example: 2 SMP + countertop
(not included)

ANGLED WALL TABLES FOR CORNERS

- Manufactured of satin stainless steel AISI-304 18/10.
- Countertop and shelf reinforced with omegas.
- Utterly welded structure.
- Legs manufactured of 40x40mm stainless steel tubes with adjustable feet by means of sanitary unseen screw.
- Straight edges to assemble onto other tables and countertops.

Model	Dimensions	RRP (€)
MMR-66	600x600x850	468
MMR-77	700x700x850	518
MMR-67	600x700x850	495
MMR-76	700x600x850	495

INTERMEDIATE SHELF FOR CORNER TABLE

- Shelves must be integrated and welded in ERATOS premises.

Model	Dimensions	RRP (€)
EBR-66	600x600x850	122
EBR-77	700x700x850	129
EBR-67/76	600x700x850	125

CORNER COUNTERTOP

- Manufactured of satin stainless steel AISI-304 18/10.
- It includes two wall supports (screws and plugs included).
- Straight edges to assemble onto other tables and countertops.

Model	Dimensions	RRP (€)
ER-66	600x600	345
ER-77	700x700	401
ER-67	600x700	373
ER-76	700x600	373

CORNER CHAMFER TABLE

- Manufactured of satin stainless steel AISI-304 18/10.
- It includes two wall supports (screws and plugs included).
- Straight edges to assemble onto other tables and countertops.

Model	Dimensions	RRP (€)
ERC-66	1000x1000 (600x600)	433
ERC-77	1000x1000 (700x700)	500
ERC-67	1000x1000 (600x700)	466
ERC-76	1000x1000 (700x600)	466

WALL STANDS

- Manufactured of stainless steel AISI-304 18/10.
- Removable height adjustable leg.
- Apt for countertops and sinks 600 and 700mm deep.

Model	Description	Dimensions	RRP (€/ud)
SM	Wall stand	410x580	95
SMP	Wall stand with leg	410x830	122

TRAYS SLIDES BODY MODULE

- Manufactured of stainless steel AISI-304 18/10.
- Easy to install (screws included).
- After delivered, they can be attached to other mounted tables.
- 8 pairs of slides, 70mm apart.

Model	Dimensions	Slides	RRP (€)
CG-GN	380x570x590	GN 1/1	290
CG-PS	660x570x590	Pasteleras	323

DRAWERS WITH TELESCOPIC SLIDES

- Manufactured of stainless steel AISI-304 18/10.
- Removable drawer with telescopic slides with brakes.
- Each well can hold a GN1/1 well.
- Easy to install (screws included).
- After delivered, they can be attached to other mounted tables.
- If they are required attached to welded mounted tables, it must be clearly indicated in the order.

Model	Dimensions	Drawers	Capacity	RRP (€)	
600	CM60	330x561x190	1	GN1/1-100	162
	CM62	390x561x440	2	GN1/1-100	279
	CM61	390x561x440	1	GN1/1-200	268
700	CM70	330x626x190	1	GN1/1-100	179
	CM72	390x626x440	2	GN1/1-100	285
	CM71	390x626x440	1	GN1/1-200	273

CHEST OF DRAWERS MODULES

- Manufactured of stainless steel AISI-304 18/10.
- Removable drawers with telescopic slides with brakes.
- Each well can hold a GN1/1 well.
- Optional individual lock.
- Easy to install (screws included).
- After delivered, they can be attached to other mounted tables.
- If they are required attached to welded mounted tables, (syllable) this clearly in the order.

Model	Dimensions	Drawers	Capacity	RRP (€)
CM3	390x562x596	3	GN1/1-100	485
CM21	390x562x596	1	GN1/1-200	522
		1	GN1/1-100	
CM12	390x562x596	1	GN1/1-100	522
		1	GN1/1-100	

INDIVIDUAL DRAWER LOCK

Model	Description	RRP (€)
OCPB	Individual drawer lock	35



TABLETOP SHELVES

- Manufactured of satin stainless steel AISI-304 18/10.
- Easy and quick installation by means of small bores on the countertop (Assembly Instructions Manual included).
- Ø30 mm rounded tube legs.
- They can be attached to any other mounted tables.
- They can be equipped with lamp strip or heat lamp strip (not included).



DISMOUNTED

Model	Dimensions	RRP (€)	Model	Dimensions	RRP (€)
ESD-71	700x350x400	259	ESD-72	700x350x700	356
ESD-91	900x350x400	263	ESD-92	900x350x700	363
ESD-111	1100x350x400	266	ESD-112	1100x350x700	369
ESD-131	1300x350x400	274	ESD-132	1300x350x700	379
ESD-151	1500x350x400	289	ESD-152	1500x350x700	409
ESD-171	1700x350x400	303	ESD-172	1700x350x700	448
ESD-191	1900x350x400	317	ESD-192	1900x350x700	462
ESD-211	2100x350x400	352	ESD-212	2100x350x700	518

WELDED

Model	Dimensions	RRP (€)	Model	Dimensions	RRP (€)
ES-71	700x350x400	306	ES-72	700x350x700	403
ES-91	900x350x400	310	ES-92	900x350x700	410
ES-111	1100x350x400	313	ES-112	1100x350x700	416
ES-131	1300x350x400	339	ES-132	1300x350x700	444
ES-151	1500x350x400	355	ES-152	1500x350x700	475
ES-171	1700x350x400	368	ES-172	1700x350x700	513
ES-191	1900x350x400	401	ES-192	1900x350x700	546
ES-211	2100x350x400	436	ES-212	2100x350x700	602

Example of assembled shelves with lamp strip and heat lamp strip, see following page.



LAMP STRIP AND HEAT LAMP STRIP

NEW DESIGN

- Manufactured of satin stainless steel AISI-304 18/10.
- Illuminated switch.
- The halogen bulbs integrate glass protection.
- Easy and quick installation.

HEAT LAMP STRIP WITH HALOGEN BULBS

- Strip to keep products warm and illuminated.
- The heat and light is realized by means of high power halogen bulbs.

Model	Dimensions	Nº of Lamps	Power	RRP (€)
PL-80	800x150x60	2	600 W	427
PL-120	1200x150x60	3	900 W	471
PL-160	1600x150x60	4	1200 W	513

HALOGEN BULBS LAMP STRIP WITH CERAMIC HEAT

- Strip to keep products warm and illuminated.
- It offers a higher intensity of heat thanks to the ceramic elements that provide intense and more concentrated heat. The illumination is produced by means of halogen bulbs and the heat produced by ceramic resistances tile type.

Model	Dimensions	Nº of Lamps and Resistances	Power	RRP (€)
PLC-80	800x150x60	2+2	890 W	603
PLC-120	1200x150x60	3+2	1210 W	666
PLC-160	1600x150x60	4+3	1530 W	796

LAMP STRIP WITH CERAMIC HEAT

- Strip to keep products warm.
- It offers a higher intensity of heat thanks to the ceramic elements that provide intense and more concentrated heat.

Model	Dimensions	Nº of Resistances	Power	RRP (€)
PCC-80	800x150x60	2	750 W	465
PCC-120	1200x150x60	3	1000 W	528
PCC-160	1600x150x60	4	1250 W	589

OPTIONAL BORE FOR FOOD WASTE ON TABLE

- Ø200mm mechanized bore on countertop.
- Removable rubber ring.

Model	Description	RRP (€)
AA-200	Agujero en encimera + Aro goma	73
AD-200	Recambio aro de goma	33

WHEELS KIT, Ø125 mm

- Ø125mm wheels.
- Two wheels with brakes are supplied in each kit.

For tables	Model	Nº of wheels	RRP (€)
≤ 2000 mm	KR4	4	190
> 2000 mm	KR6	6	278

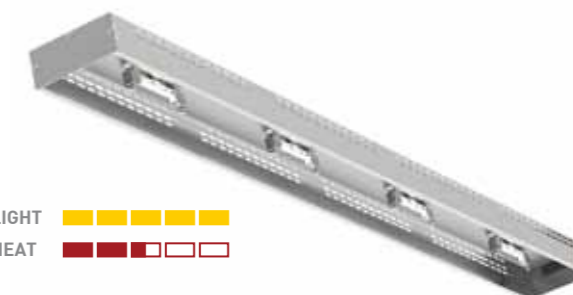

LIGHT 
HEAT 

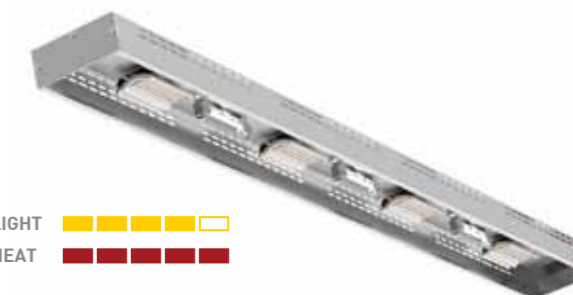

LIGHT 
HEAT 

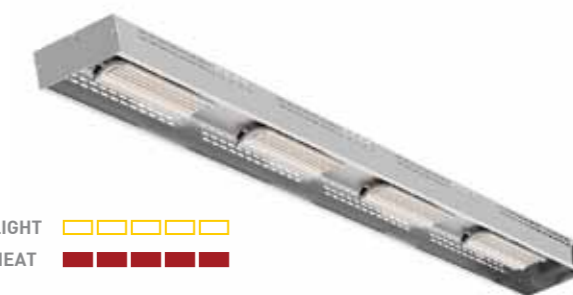

LIGHT 
HEAT 



WELDED WELL ON TABLES

- Stainless steel AISI-304 18/10 well with drainage and sound-proof cover, 400x440x250mm.

Model	Description-Well position	RRP (€)
CSE-44D	Well welded on the right	191
CSE-44I	Well welded on the left	191
CSE-44C	Well welded in the centre	191



WALL CUTTING TABLES

- Manufactured of satin stainless steel AISI-304 18/10.
- Countertop and optional shelf with omegas reinforcement.
- Removable white 20mm thick polystyrene cover.
- Legs manufactured of 40x40mm stainless steel tubes with height adjustable feet by means of sanitary unseen screw.
- Unassembled models offer a robust structure reinforced by means of skirts to provide utter solidity.
- The assembled tables are supplied totally welded.

CUTTING TABLE WITH SHELF



UNASSEMBLED			
	Model	Dimensions	RRP (€)
600	MMCED60-100	1000x600x850	794
	MMCED60-150	1500x600x850	908
700	MMCED70-100	1000x700x850	858
	MMCED70-150	1500x700x850	985
WELDED			
	Model	Dimensions	RRP (€)
600	MMCE60-100	1000x600x850	842
	MMCE60-150	1500x600x850	963
700	MMCE70-100	1000x700x850	910
	MMCE70-150	1500x700x850	1044

CUTTING TABLES WITHOUT SHELF



UNASSEMBLED			
	Model	Dimensions	RRP (€)
600	MMCS60-100	1000x600x850	738
	MMCS60-150	1500x600x850	807
700	MMCS70-100	1000x700x850	800
	MMCS70-150	1500x700x850	776
WELDED			
	Model	Dimensions	RRP (€)
600	MMCS60-100	1000x600x850	782
	MMCS60-150	1500x600x850	855
700	MMCS70-100	1000x700x850	848
	MMCS70-150	1500x700x850	823

CUTTING PYLON



- Manufactured of stainless steel AISI-304 18/10.
- Legs manufactured of 40x40mm stainless steel tubes with height adjustable feet by means of sanitary unseen screw.
- Reinforced structure, with inferior shelf included.
- They are supplied totally welded.
- Removable white 50 or 100mm thick polystyrene cover.

Model	Dimensions	RRP (€)
PC50-50	500x500x850	459
PC50-100	500x500x900	634

GASTRONOMY AND BAKERY OVEN SUPPORT TABLES

NEW

- All models are supplied totally welded.
- Designed to allocate gastronomy and bakery ovens.
- Models with or without slides.
- Entirely manufactured of satin stainless steel AISI-304 18/10 and omega reinforcement.
- Models without slides integrate stainless steel AISI-304 18/10 lower shelf.
- Stainless steel AISI-304 18/10 slides body.
- 50mm front edges totally welded.
- Legs manufactured of 40x40mm stainless steel tubes with adjustable feet by means of sanitary unseen screw. Adjustable height between 70 and 76cm.



TABLES WITH GASTRO-NORM SLIDES

Model	Dimensions	Capacity	RRP (€)
MHG-8575	850 x 750 x 700	2 slides bodies for 6 GN 1/1	601
MHG-8585	850 x 850 x 700	2 slides bodies for 6 GN 1/1	636
MHG-1085	1100 x 850 x 700	1 slides body for 6 GN 1/1 and 1 for 6 GN2/1	733
MHG-1095	1100 x 950 x 700	1 slides body for 6 GN 1/1 and 1 for 6 GN2/1	776



BAKERY TABLES SLIDES, 60X40CM

Model	Dimensions	Capacity	RRP (€)
MHP-8585	850x850x700	1 slides body for 6 cans 400x600	612
MHP-1085	1100x850x700	2 slides bodies for 6 cans 400x600	670



SUPPORT TABLE WITHOUT SLIDES

Model	Dimensions	Capacity	RRP (€)
MH-8575	850 x 750 x 700	Without slides - with shelf	472
MH-8585	850 x 850 x 700	Without slides - with shelf	488
MH-1085	1100 x 850 x 700	Without slides - with shelf	568
MH-1095	1100 x 950 x 700	Without slides - with shelf	579



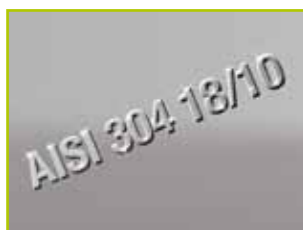

Maximum quality
Products manufactured in AISI 304 18/10 Stainless Steel. Designed for a lasting professional use, with functional lines and robust, solid, hygienic finish.



Ergonomics and productivity
Professional, ergonomic, compact and very well equipped tables. Designed to organize and facilitate the barman development thus enhancing her/his productivity and the business profit.



Refrigerated models
The refrigerated models are very compact and functional cocktail stations. They contain cold storage with ample totally removable drawers with telescopic guide rails.



Insulated well
Big well insulated with high density and thickness injected polyurethane, welded, watertight and with drainage. It contains double drilled bottom, mobile divisions and wells



Professional functionality
Sink with tap, double drilled bottom and countertop glass rinser, removable cutting top with waste container, polypropylene bar cocktail stoppers, blender support, speed track, etc.



Broad range
There is a station for each possible necessity. Basic models, for combined cocktails, professional cocktail tables, refrigerated cocktail stations, mobile cocktail stations with counter and decorated panel, etc.



Options and accessories
Depending on the model, options and accessories such as a second speed track, GN buckets for ingredients, various types of taps, wheels, upper counter and decorated panel can be added.



Availability
All tables and cocktail stations in ERATOS catalogue as well as their options, are available for shipping in a reduced delivery time from 24 to 74 hours, depending on the model.

COMBINED COCKTAIL PREPARATION TABLE

NEW

- Satin 304 18/10 stainless steel table.
- 40x40 mm stainless steel tube structure welded to the countertop.
- Model manufactured with lower shelf and back reinforcement.
- Stainless steel, height adjustable legs by means of hidden screw.
- Countertop with 40mm high backsplash.
- 520x200 mm countertop surface.
- Thermally insulated well with ecologic injected polyurethane 725x405x300mm and incorporated drainage.

- It contains drilled bottom in the entire well, as well as 2 mobile divisions.
- Insulated well capacity: 2 areas for ice, 1 area for bottles, 1 area for 7 GN 1/9-100 wells (wells not included in the price, see optional kit KCB -120)
- 900x110mm front speed track with capacity for 10/11 bottles, easily removable. Optionally, a second track can be included; model CRB-100 can be added.
- It contains a beating board for polyethylene cocktail lid, removable for its thorough cleaning.



Model MBCN-100 + optional wells kit KCB-125 and second bottles track CRB-100



Model MBCN-100-E



Model MBCN-100-E



Optional: second track for bottles. Model CRB-100

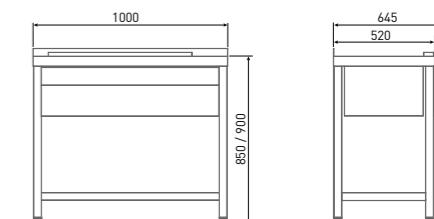

Model	Description	Type	Dimensions	Dimensions with 2 ^o track	RRP (€)
MBCN-100-E	Table with insulated well	With shelf	1000x645x900	1000x780x900	1.230
MBCN-100	Table with insulated well	With rear reinforcement	1000x645x900	1000x780x900	1.230
OPTIONS					
CRB-100	2 ^o bottles speed track		910x135x260		161
KCB-120	Kit 7 stainless steel GN wells 1/9 100 mm				113,4

ON-COUNTER TRAYS

NEW

- Designed to be placed on top of the bars.
- Stainless steel AISI 304 kit base and grilles.
- Base drawer with hole and tube for liquid drainage.

Model	Dimensions	Nº of grilles	RRP (€)
KBN-120	1202x202x21	3	202
KBN-160	1602x202x21	4	261
KBN-200	2002x202x21	5	296



NEW

COCKTAIL TABLES AND MODULES

SIMPLE TABLE

- Manufactured in satin AISI 304 18/10 stainless steel.
- Stainless steel tube structure 40x40 welded onto countertop.
- Two models available: one with lower shelf and another one with back reinforcement.
- Countertop with backsplash 40mm.
- Sink 275x250x150mm with fit-in drainage.
- Single lever tap included.
- Pressure glass rinser with removable grille.
- 1 removable waste container.
- It contains 2 cutting/beating boards, polyethylene cocktail stopper, removable for proper cleaning, 1 x (190x260x20mm) and 1 x (730x60x20mm).
- Well thermally insulated with ecologic injected polyurethane, 725x405x300mm and fit-in drainage.
- It includes drilled bottom in the entire well, as well as 3 mobile divisions.
- Capacity of insulated well: 1 area for bottles, 2 areas for ice and 1 area for wells of 7 wells GN 1/9 (not included in the price, see optional kit KCB-120)
- Speed track of 785mm with capacity for 7/9 bottles, easily removable. Optionally, a second track can be added.
- 1 bracket for blender and/or mixer with lead-through hole, easily removable.



Model MBCN-120-E



Height adjustable legs

Single lever tap



Model MBCN-120 + optional KCB-120 well kit and 2° bottles track CRB-120



Optional, 2° bottles track, model CRB-120



Model MBCN-120-E top view

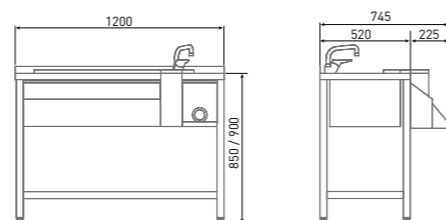

Model	Description	Type	Dimensions	Dimensions with 2° track	RRP (€)
MBCN-120-E	Simple table for cocktail preparation	With shelf	1200x745x900	1200x785x900	1.572
MBCN-120	Simple table for cocktail preparation	With rear reinforcement	1200x745x900	1200x785x900	1.572
OPTIONS					
KCB-120	7 SST GN 1/9 wells 100mm				113,4
CRB-120	2° bottles speed track		785x135x260		115

DOUBLE TABLE

- Manufactured in satin AISI 304 18/10 stainless steel.
- Stainless steel tube structure 40x40 welded onto countertop.
- Countertop with backsplash 40mm.
- Two models available: one with lower shelf and another one with back reinforcement.
- 2 sinks 275x250x150mm with fit-in drainage.
- 2 single lever taps included.
- 2 pressure glass rinsers with removable grille.
- 2 removable waste containers.
- It contains 3 cutting/beating boards, polyethylene cocktail stopper, both removable for proper cleaning, 2 x (190x260x20mm) + 1 x (1265x60x20mm).
- Well thermally insulated with ecologic injected polyurethane, 1265x400x300mm.
- It includes drilled bottom in the entire well, as well as 4 mobile divisions.
- Capacity for insulated well: 2 areas for bottles, 3 areas for ice and 1 area for wells of 12 wells GN 1/9-100 (not included in the price, see optional kit KCB-200)
- Speed track of 1265mm with capacity for 13/15 bottles, easily removable. Optionally, a second track can be added.
- 2 front brackets for blender and/or mixer with lead-through hole, easily removable.

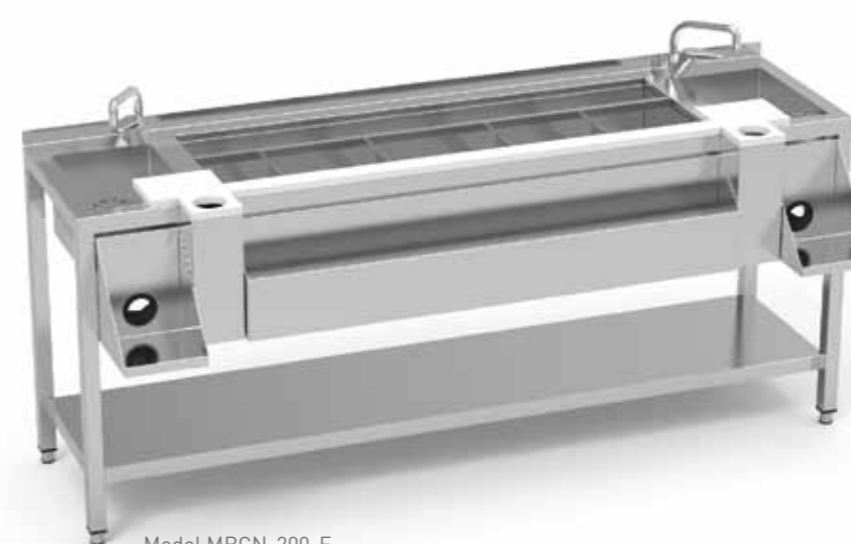

Model MBCN-200-E



Mobile dividers included.

Removable waste container.



Optional, 2° bottle track, model CRB-200



Model MBCN-200-E top view



Model MBCN-200 + KCB-200 wells kit and 2° bottle track CRB-200

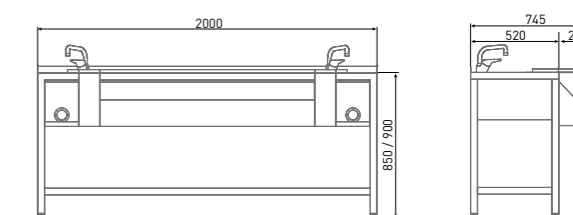

Model	Description	Type	Dimensions	Dimensions with 2° track	RRP (€)
MBCN-200-E	Double table for cocktail preparation	With shelf	2000x745x900	2000x785x900	2.658
MBCN-200	Double table for cocktail preparation	With rear reinforcement	2000x745x900	2000x785x900	2.658
OPTIONS					
KCB-200	12 SST kit GN 1/9 wells 100mm				194,4
CRB-200	2° bottles speed track		1265x135x260		143

NEW

COCKTAIL STATIONS WITH REFRIGERATED DRAWERS

SIMPLE STATION WITH 2 REFRIGERATED DRAWERS

- Manufactured in satin AISI 304 18/10 stainless steel.
- Countertop with backsplash 40mm.
- Stainless steel height adjustable legs.
- Sink 275x250x150mm with fit-in drainage.
- 1 pressure glass rinsers with removable grille.
- 1 removable waste container.
- It contains 2 cutting/beating boards, polyethylene cocktail stopper, 190x260x20mm and 730x60x20mm.
- Well thermally insulated with ecologic injected polyurethane of 725x405x300mm and fit-in drainage.
- It includes drilled bottom in the entire well, as well as 2 mobile divisions.
- Capacity of insulated well: 1 area for bottles, 2 areas for ice

- and 1 area for wells of 7 wells GN 1/9 (not included in the price, see optional kit KCB-120)
- Speed track of 785mm with capacity for 7/9 bottles.
- 1 support for blender and/or mixer with lead-trough hole, easily removable.
- Single lever tap included.
- 2 removable stainless steel refrigerated drawers with SST telescopic rails with auto-lock system.
- Injected polyurethane insulation of 40 kg/m3 density.
- Ventilated condenser unit, ¾ parts removable.
- Ventilated evaporator with anti-corrosion cover.
- Temperature range: -2°C+8°C



Model MBCR-120



Refrigerated drawers Blender support



Model MBCR + optional wells kit KCB-120



Top view model MBCR-120

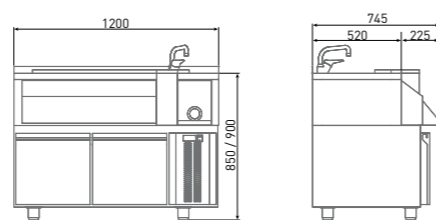

Model	Description	Dimensions	Refrig.Power	Consumption	Voltage	RRP (€)
MBCR-120	Simple cabinet with 2 refrigerated drawers	1200x745x900	305W	330W	230V 50Hz	4.718
OPTIONS						
KCB-120	7 wells kit GN 1/9 100mm					113,4

DOUBLE STATION WITH 3 REFRIGERATED DRAWERS

- Manufactured in satin AISI 304 18/10 stainless steel.
- Countertop with backsplash 40mm.
- Stainless steel height adjustable legs.
- 2 sinks 275x250x150mm with fit-in drainage.
- 2 pressure glass rinsers with removable grille.
- 2 removable waste containers.
- It contains 3 cutting/beating boards, polyethylene cocktail stopper, 2 x (190x260x20mm) + 1 x (1265x60x20mm).
- Well thermally insulated with ecologic injected polyurethane of 1265x400x300mm and fit-in drainage.
- Capacity of insulated well: 2 areas for bottles, 3 areas for ice and 1 area for wells of 12 wells GN 1/9 (not included in the price, see optional kit KCB-200)

- It includes drilled bottom in the entire well, as well as 2 mobile divisions.
- Speed track of 1265mm with capacity for 14/16 bottles, easily removable.
- 2 supports for blender and/or mixer with lead-through hole, easily removable.
- 2 single lever taps included in the price.
- 3 removable stainless steel refrigerated drawers, with telescopic rails with auto-lock system.
- Injected polyurethane insulation of 40 kg/m3 density.
- Ventilated condenser unit, ¾ parts removable.
- Ventilated evaporator with anti-corrosion cover.
- Temperature range: -2°C+8°C.



Single lever tap included Divisions and drilled bottom included



Model MBCR-200



Model MBCR-200 + optional wells kit KCB-200



Model MBCR-200 top view

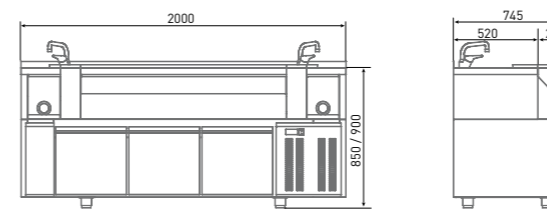

Model	Description	Dimensions	Refrig.Power	Consumption	Voltage	RRP (€)
MBCR-200	Double cabinet with 3 refrigerated drawers	2000x745x900	330W	520W	230V 50Hz	6.688
OPTIONS						
KCB-200	12 wells kit GN 1/9 100mm					194,4

COCKTAIL STATION

- Manufactured in satin AISI 304 18/10 stainless steel.
- Robust structure manufactured in stainless steel welded onto countertop and lower shelf. Countertop with backsplash of 100mm.
- Sink 300x250x150mm with fit-in drainage.
- Low pipe single lever tap included.
- Pressure glass rinser with removable grille.
- Waste hole.
- Polyethylene cutting board of 190x190x20mm.
- Well thermally insulated with ecologic injected polyurethane

- of 940x450x300mm and fit-in drainage.
- Capacity of insulated well: 2 areas for bottles, 2 areas for ice and 1 area for wells GN 1/9 and 2 GN1/6 (wells not included in the price, see optional kit KCB-160)
- It includes drilled bottom in the entire well, as well as 3 mobile divisions.
- Front speed track with capacity for 14/16 bottles, easily removable.
- Front supports for blender or mixer with lead-through hole, easily removable.

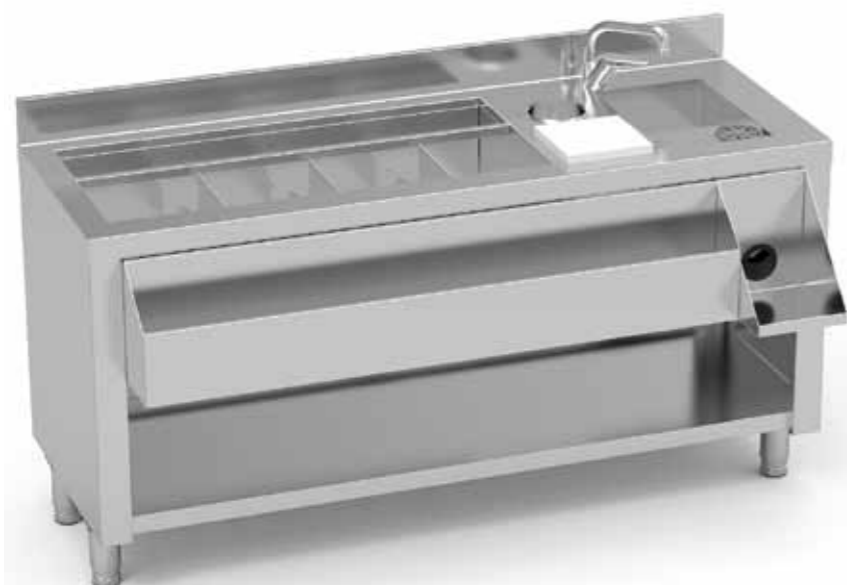

Model MBC-160



Single lever tap included



Optional wells kit: KCB-160



Model MBC-160 + optional wells kit KCB-160 and second bottles track CRB-160



Optional 2° bottles track CRB-160



Model MBC-160 top view with optional wells kit GN, model KCB-160

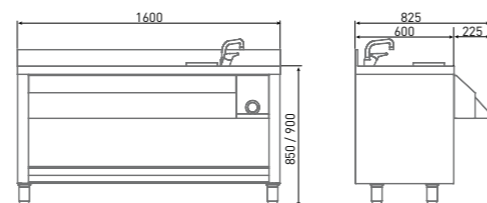

Model	Dimensions	Dimension with front track	RRP (€)
MBC-160	1600x825x900	1600x865x900	2.245

OPTIONS

- Optional counter equipped with:
 - Counter of 1600x280x40mm.
 - Counter support.
 - White laminated steel rails and decorative panel. Optionally, the colours can be changed by any of the ample range of colours shown at the bottom.
 - It contains 4 wheels of Ø125mm, 2 of them with brakes.
- Optional kit of 6 wells GN 1/9-100 y 2 GN1/6-100 stainless steel, model KCB-160
- Optional 2° bottles speed track: CRB-160



Optional counter kit, model KEB-160

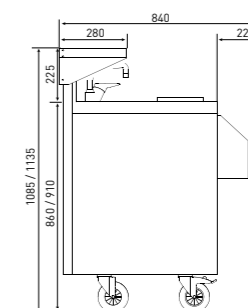

Optional 2° bottles speed track.

Model	Description	Dimensions	RRP (€)
KEB-160	Counter and supports kit with back rails and white decorative panels	1495x815	307
KCB-160	SST wells kit GN, composed of 6 GN1/9-100 and 2 GN1/6-100		127,20
CRB-160	2° bottles speed track (15/16)	1135x135x260	131

DECORATIVE PANELS

- White is the standard colour of the counter kit KEB-160.
- Optionally, standard white colour can be changed by laminated steel decorative panels in plain colours, wood-effect design or stainless steel.
- Optionally, panels can be manufactured in any colour and with customized decoration with vinyl film. Inquire prices.



COLOUR CHANGE FROM STANDARD WHITE TO PLAIN COLOUR PANEL

YELLOW	ORANGE	RED	BOURDEAUX	BLUE	GREEN	GRAY	BEIGE	BLACK	RRP (€)
RAL-1023	RAL-2008	RAL-3020	RAL-3003	RAL-5003	RAL-6001	RAL-7040	RAL-1015	RAL-9005	65
MBP-160-AM	MBP-160-NA	MBP-160-RO	MBP-160-BU	MBP-160-AZ	MBP-160-VE	MBP-160-GR	MBP-160-BE	MBP-160-NE	

COLOUR CHANGE FROM STANDARD WHITE TO STAINLESS STEEL

SATIN	RRP (€)
MBP-160-SA	198

COLOUR CHANGE FROM STANDARD WHITE TO WOOD-EFFECT DESIGN

WENGUE	WALNUT	BEECH	RRP (€)
MBP-160-WE	MBP-160-NO	MBP-160-HA	192



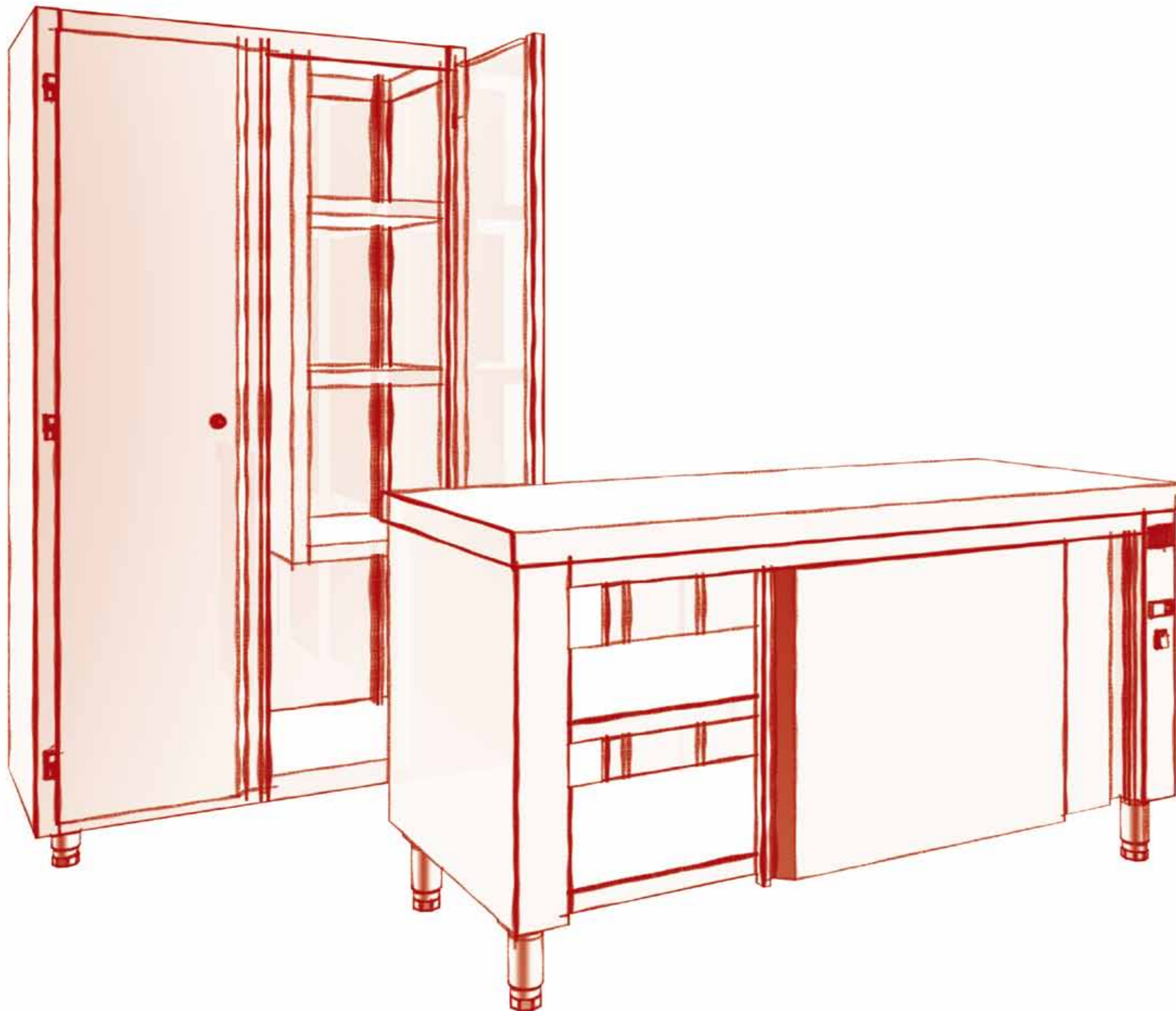

NEUTRAL AND HOT FURNITURE

Closed neutral furniture with sliding doors	page 70
Neutral open furniture	page 72
Neutral closed furniture with hinged doors	page 74
Neutral furniture with doors and drawers	page 76
Neutral open furniture 600mm high	page 77
Corner modules	page 78
Slides body module	page 78
Auxiliary elements for modules and waste disposal bore option	page 79
Neutral chest of drawers	page 80
Wall and central hot tables with sliding doors	page 82
Bein-marie warmers	page 84
Tabletop bein-marie warmers	page 85
Bein-marie trolleys	page 85
Tall cabinets	page 86
Cleaners cabinets	page 86
Wall cabinets	page 87
Countertops for furniture	page 88
Plinths and wheels kit	page 90
Examples modular compositions	page 91

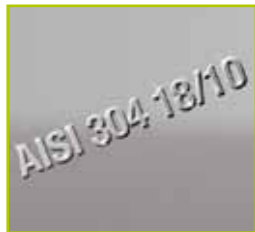

Maximum quality

Products manufactured of stainless steel AISI 304 18/10, with functional, elegant and uniform lines designs with perfect, solid, hygienic finishes.



Robustness

All furniture has been carefully designed and reinforced to provide the reliability needed for a professional use. Including neutral furniture is solid, stable and long-lasting.



Modularity

We offer a high standard modular design system which enables monoblock sets adapted to any quick, easy and economical necessity.



Countertop

They can be customised and are supplied utterly welded with backsplash and sanitary rounded fronts. Reinforced and soundproof with high thickness omegas.



Heated tables

Manufactured of high quality components. They offer a maximum energetic efficiency thanks to their integral insulation by means of double wall and fibreglass in furniture as well as in doors.



Uniform design

The countertops, tables and neutral furniture can be combined with tables, sinks and other products from our catalogue thanks to their uniform aesthetic design.



Practical details

Drawers and serving units are manufactured with soft closing system and full extension telescopic slides. They integrate suspended sliding doors with unseen upper slide. Tilted furniture tops.



Complements

Our vast offer of complementary products including wall shelves, extractor hoods, tables or sinks enables the most personal solution to any possible necessity.

CLOSED NEUTRAL FURNITURE WITH SLIDING DOORS

- Countertops manufactured of satin stainless steel AISI-304 18/10.
- Countertops with 100 mm backsplash (on wall models) and 50mm rounded fronts, entirely welded.
- Countertops and shelves with omegas reinforcement.
- Intermediate shelf adjustable in height by means of highly resistant support.
- Suspended sliding doors of smooth slide by means of rail with ball bearing.
- Robust legs, height adjustable by unseen screws.
- Modular furniture easily integrated to any other modular neutral elements by means of common or independent countertop.
- Possibility of integrating a key lock, model OCPC: 88 €.

CROSSING SLIDING DOORS FURNITURE



CENTRAL COUNTERTOP			
	Model	Dimensions	RRP (€)
RANGE 600	MNCP60-100C	1000x600x850	1.229
	MNCP60-120C	1200x600x850	1.315
	MNCP60-140C	1400x600x850	1.402
	MNCP60-160C	1600x600x850	1.490
	MNCP60-180C	1800x600x850	1.669
	MNCP60-200C	2000x600x850	1.728
RANGE 700	MNCP70-100C	1000x700x850	1.263
	MNCP70-120C	1200x700x850	1.349
	MNCP70-140C	1400x700x850	1.520
	MNCP70-160C	1600x700x850	1.569
	MNCP70-180C	1800x700x850	1.708
	MNCP70-200C	2000x700x850	1.818



WITHOUT COUNTERTOP			
	Model	Dimensions	RRP (€)
RANGE 600	MNCP60-100	1000x600x850	997
	MNCP60-120	1200x600x850	1.067
	MNCP60-140	1400x600x850	1.138
	MNCP60-160	1600x600x850	1.206
	MNCP60-180	1800x600x850	1.362
	MNCP60-200	2000x600x850	1.396
RANGE 700	MNCP70-100	1000x700x850	1.010
	MNCP70-120	1200x700x850	1.078
	MNCP70-140	1400x700x850	1.229
	MNCP70-160	1600x700x850	1.258
	MNCP70-180	1800x700x850	1.371
	MNCP70-200	2000x700x850	1.453

Consult countertops on pages 88-89

SLIDING DOORS FURNITURE

WALL COUNTERTOP

	Model	Dimensions	RRP (€)
RANGE 600	MNC60-100M	1000x600x850	1.023
	MNC60-120M	1200x600x850	1.092
	MNC60-140M	1400x600x850	1.163
	MNC60-160M	1600x600x850	1.266
	MNC60-180M	1800x600x850	1.339
	MNC60-200M	2000x600x850	1.421
RANGE 700	MNC70-100M	1000x700x850	1.071
	MNC70-120M	1200x700x850	1.178
	MNC70-140M	1400x700x850	1.229
	MNC70-160M	1600x700x850	1.314
	MNC70-180M	1800x700x850	1.389
	MNC70-200M	2000x700x850	1.460



CENTRAL COUNTERTOP

	Model	Dimensions	RRP (€)
RANGE 600	MNC60-100C	1000x600x850	997
	MNC60-120C	1200x600x850	1.067
	MNC60-140C	1400x600x850	1.136
	MNC60-160C	1600x600x850	1.239
	MNC60-180C	1800x600x850	1.314
	MNC60-200C	2000x600x850	1.400
RANGE 700	MNC70-100C	1000x700x850	1.043
	MNC70-120C	1200x700x850	1.150
	MNC70-140C	1400x700x850	1.199
	MNC70-160C	1600x700x850	1.282
	MNC70-180C	1800x700x850	1.359
	MNC70-200C	2000x700x850	1.436



WITHOUT COUNTERTOP

	Model	Dimensions	RRP (€)
RANGE 600	MNC60-100	1000x600x850	765
	MNC60-120	1200x600x850	819
	MNC60-140	1400x600x850	872
	MNC60-160	1600x600x850	955
	MNC60-180	1800x600x850	1.007
	MNC60-200	2000x600x850	1.068
RANGE 700	MNC70-100	1000x700x850	790
	MNC70-120	1200x700x850	879
	MNC70-140	1400x700x850	908
	MNC70-160	1600x700x850	971
	MNC70-180	1800x700x850	1.022
	MNC70-200	2000x700x850	1.071



Consult countertops on pages 88-89

NEUTRAL OPEN FURNITURE

- Manufactured of satin stainless steel AISI-304 18/10.
- Countertops with 100 mm backsplash (on wall models) and 50mm rounded fronts, entirely welded.
- Countertops and shelves with omegas reinforcement.
- Intermediate shelf adjustable in height by means of highly resistant support.
- Robust legs, height adjustable by unseen screws.
- Modular furniture easily integrated to any other modular neutral elements by means of common or independent counter-top.

NEUTRAL FURNITURE CROSSING OPEN



CENTRAL COUNTERTOP			
	Model	Dimensions	RRP (€)
RANGE 600	MNAP60-60C	600x600x850	666
	MNAP60-80C	800x600x850	690
	MNAP60-100C	1000x600x850	720
	MNAP60-120C	1200x600x850	771
	MNAP60-140C	1400x600x850	821
	MNAP60-160C	1600x600x850	874
	MNAP60-180C	1800x600x850	930
	MNAP60-200C	2000x600x850	1.005
	MNAP60-220C	2200x600x850	1.109
	MNAP60-240C	2400x600x850	1.183
RANGE 700	MNAP70-60C	600x700x850	688
	MNAP70-80C	800x700x850	713
	MNAP70-100C	1000x700x850	742
	MNAP70-120C	1200x700x850	795
	MNAP70-140C	1400x700x850	872
	MNAP70-160C	1600x700x850	905
	MNAP70-180C	1800x700x850	963
	MNAP70-200C	2000x700x850	1.042
	MNAP70-220C	2200x700x850	1.148
	MNAP70-240C	2400x700x850	1.228



WITHOUT COUNTERTOP			
	Model	Dimensions	RRP (€)
RANGE 600	MNAP60-60	600x600x850	457
	MNAP60-80	800x600x850	472
	MNAP60-100	1000x600x850	488
	MNAP60-120	1200x600x850	523
	MNAP60-140	1400x600x850	557
	MNAP60-160	1600x600x850	590
	MNAP60-180	1800x600x850	623
	MNAP60-200	2000x600x850	673
	MNAP60-220	2200x600x850	752
	MNAP60-240	2400x600x850	801
RANGE 700	MNAP70-60	600x700x850	461
	MNAP70-80	800x700x850	475
	MNAP70-100	1000x700x850	489
	MNAP70-120	1200x700x850	524
	MNAP70-140	1400x700x850	581
	MNAP70-160	1600x700x850	594
	MNAP70-180	1800x700x850	626
	MNAP70-200	2000x700x850	677
	MNAP70-220	2200x700x850	754
	MNAP70-240	2400x700x850	805

Consult countertops on pages 88-89

NEUTRAL OPEN FURNITURE

WALL COUNTERTOP

	Model	Dimensions	RRP (€)
RANGE 600	MNA60-60M	600x600x850	726
	MNA60-80M	800x600x850	757
	MNA60-100M	1000x600x850	791
	MNA60-120M	1200x600x850	846
	MNA60-140M	1400x600x850	901
	MNA60-160M	1600x600x850	958
	MNA60-180M	1800x600x850	1.015
	MNA60-200M	2000x600x850	1.090
RANGE 700	MNA70-60M	600x700x850	751
	MNA70-80M	800x700x850	780
	MNA70-100M	1000x700x850	817
	MNA70-120M	1200x700x850	873
	MNA70-140M	1400x700x850	932
	MNA70-160M	1600x700x850	991
	MNA70-180M	1800x700x850	1.051
	MNA70-200M	2000x700x850	1.128
RANGE 700	MNA70-220M	2200x700x850	1.247
	MNA70-240M	2400x700x850	1.332



CENTRAL COUNTERTOP

	Model	Dimensions	RRP (€)
RANGE 600	MNA60-60C	600x600x850	702
	MNA60-80C	800x600x850	731
	MNA60-100C	1000x600x850	765
	MNA60-120C	1200x600x850	821
	MNA60-140C	1400x600x850	874
	MNA60-160C	1600x600x850	931
	MNA60-180C	1800x600x850	990
	MNA60-200C	2000x600x850	1.069
	MNA60-220C	2200x600x850	1.180
	MNA60-240C	2400x600x850	1.259
RANGE 700	MNA70-60C	600x700x850	722
	MNA70-80C	800x700x850	753
	MNA70-100C	1000x700x850	789
	MNA70-120C	1200x700x850	845
	MNA70-140C	1400x700x850	902
	MNA70-160C	1600x700x850	959
	MNA70-180C	1800x700x850	1.021
	MNA70-200C	2000x700x850	1.104
	MNA70-220C	2200x700x850	1.220
	MNA70-240C	2400x700x850	1.303



WITHOUT COUNTERTOP

	Model	Dimensions	RRP (€)
RANGE 600	MNA60-60	600x600x850	493
	MNA60-80	800x600x850	513
	MNA60-100	1000x600x850	533
	MNA60-120	1200x600x850	573
	MNA60-140	1400x600x850	610
	MNA60-160	1600x600x850	647
	MNA60-180	1800x600x850	683
	MNA60-200	2000x600x850	737
	MNA60-220	2200x600x850	823
	MNA60-240	2400x600x850	877
RANGE 700	MNA70-60	600x700x850	495
	MNA70-80	800x700x850	515
	MNA70-100	1000x700x850	536
	MNA70-120	1200x700x850	574
	MNA70-140	1400x700x850	611
	MNA70-160	1600x700x850	648
	MNA70-180	1800x700x850	684
	MNA70-200	2000x700x850	739
	MNA70-220	2200x700x850	826
	MNA70-240	2400x700x850	880



Consult countertops on pages 88-89

NEUTRAL CLOSED FURNITURE WITH HINGED DOORS

- Countertops manufactured of satin stainless steel AISI-304 18/10.
- Countertops with 100mm backsplash (on wall models) and 50mm rounded fronts, entirely welded.
- Countertops and shelves with omegas reinforcement.
- Intermediate shelf adjustable in height by means of highly resistant support.
- Hinged doors by means of sturdy unseen hinge.
- Robust legs, height adjustable by unseen screws.
- Modular furniture easily integrated to any other modular neutral elements by means of common or independent countertop.
- Possibility of integrating a key lock, model OCPB: 35€ (per door)

HINGED DOORS FURNITURE CROSSING OPEN



CENTRAL COUNTERTOP				
	Model	Dimensions	Nº Puertas	RRP (€)
RANGE 600	MNBP60-60C	600x600x850	1+1	951
	MNBP60-80C	800x600x850	2+2	1.219
	MNBP60-100C	1000x600x850	2+2	1.314
	MNBP60-120C	1200x600x850	2+2	1.411
	MNBP60-140C	1400x600x850	3+3	2.007
	MNBP60-160C	1600x600x850	3+3	2.286
	MNBP60-180C	1800x600x850	3+3	2.390
	MNBP60-200C	2000x600x850	4+4	2.496
RANGE 700	MNBP60-220C	2200x600x850	4+4	2.602
	MNBP60-240C	2400x600x850	4+4	2.708
	MNBP70-60C	600x700x850	1+1	992
	MNBP70-80C	800x700x850	2+2	1.261
	MNBP70-100C	1000x700x850	2+2	1.344
	MNBP70-120C	1200x700x850	2+2	1.430
	MNBP70-140C	1400x700x850	3+3	2.079
	MNBP70-160C	1600x700x850	3+3	2.357
RANGE 700	MNBP70-180C	1800x700x850	3+3	2.451
	MNBP70-200C	2000x700x850	4+4	2.547
	MNBP70-220C	2200x700x850	4+4	2.644
	MNBP70-240C	2400x700x850	4+4	2.741



WITHOUT COUNTERTOP				
	Model	Dimensions	Nº Puertas	RRP (€)
RANGE 600	MNBP60-60	600x600x850	1+1	742
	MNBP60-80	800x600x850	2+2	1.001
	MNBP60-100	1000x600x850	2+2	1.082
	MNBP60-120	1200x600x850	2+2	1.163
	MNBP60-140	1400x600x850	3+3	1.743
	MNBP60-160	1600x600x850	3+3	2.002
	MNBP60-180	1800x600x850	3+3	2.083
	MNBP60-200	2000x600x850	4+4	2.164
RANGE 700	MNBP60-220	2200x600x850	4+4	2.245
	MNBP60-240	2400x600x850	4+4	2.326
	MNBP70-60	600x700x850	1+1	765
	MNBP70-80	800x700x850	2+2	1.023
	MNBP70-100	1000x700x850	2+2	1.091
	MNBP70-120	1200x700x850	2+2	1.159
	MNBP70-140	1400x700x850	3+3	1.788
	MNBP70-160	1600x700x850	3+3	2.046
RANGE 700	MNBP70-180	1800x700x850	3+3	2.114
	MNBP70-200	2000x700x850	4+4	2.182
	MNBP70-220	2200x700x850	4+4	2.250
	MNBP70-240	2400x700x850	4+4	2.318

Consult countertops on pages 88-89

HINGED DOORS FURNITURE

WALL COUNTERTOP

	Model	Dimensions	Nº Puertas	RRP (€)
RANGE 600	MNB60-60M	600x600x850	1	820
	MNB60-80M	800x600x850	2	1.036
	MNB60-100M	1000x600x850	2	1.114
	MNB60-120M	1200x600x850	2	1.193
	MNB60-140M	1400x600x850	3	1.670
	MNB60-160M	1600x600x850	3	1.895
	MNB60-180M	1800x600x850	3	1.980
	MNB60-200M	2000x600x850	4	2.065
RANGE 700	MNB60-220M	2200x600x850	4	2.162
	MNB60-240M	2400x600x850	4	2.257
	MNB70-60M	600x700x850	1	861
	MNB70-80M	800x700x850	2	1.074
	MNB70-100M	1000x700x850	2	1.144
	MNB70-120M	1200x700x850	2	1.216
	MNB70-140M	1400x700x850	3	1.735
	MNB70-160M	1600x700x850	3	1.961
RANGE 700	MNB70-180M	1800x700x850	3	2.039
	MNB70-200M	2000x700x850	4	2.115
	MNB70-220M	2200x700x850	4	2.201
	MNB70-240M	2400x700x850	4	2.286

CENTRAL COUNTERTOP

	Model	Dimensions	Nº Puertas	RRP (€)
RANGE 600	MNB60-60C	600x600x850	1	796
	MNB60-80C	800x600x850	2	1.010
	MNB60-100C	1000x600x850	2	1.088
	MNB60-120C	1200x600x850	2	1.168
	MNB60-140C	1400x600x850	3	1.643
	MNB60-160C	1600x600x850	3	1.868
	MNB60-180C	1800x600x850	3	1.955
	MNB60-200C	2000x600x850	4	2.044
RANGE 700	MNB60-220C	2200x600x850	4	2.133
	MNB60-240C	2400x600x850	4	2.222
	MNB70-60C	600x700x850	1	832
	MNB70-80C	800x700x850	2	1.047
	MNB70-100C	1000x700x850	2	1.116
	MNB70-120C	1200x700x850	2	1.188
	MNB70-140C	1400x700x850	3	1.705
	MNB70-160C	1600x700x850	3	1.929
RANGE 700	MNB70-180C	1800x700x850	3	2.009
	MNB70-200C	2000x700x850	4	2.091
	MNB70-220C	2200x700x850	4	2.174
	MNB70-240C	2400x700x850	4	2.257

WITHOUT COUNTERTOP

	Model	Dimensions	Nº Puertas	RRP (€)
RANGE 600	MNB60-60	600x600x850	1	587
	MNB60-80	800x600x850	2	792
	MNB60-100	1000x600x850	2	856
	MNB60-120	1200x600x850	2	920
	MNB60-140	1400x600x850	3	1.379
	MNB60-160	1600x600x850	3	1.584
	MNB60-180	1800x600x850	3	1.648
	MNB60-200	2000x600x850	4	1.712
RANGE 700	MNB60-220	2200x600x850	4	1.776
	MNB60-240	2400x600x850	4	1.840
	MNB70-60	600x700x850	1	605
	MNB70-80	800x700x850	2	809
	MNB70-100	1000x700x850	2	863
	MNB70-120	1200x700x850	2	917
	MNB70-140	1400x700x850	3	1.414
	MNB70-160	1600x700x850	3	1.618
RANGE 700	MNB70-180	1800x700x850	3	1.672
	MNB70-200	2000x700x850	4	1.726
	MNB70-220	2200x700x850	4	1.780
	MNB70-240	2400x700x850	4	1.834

Consult countertops on pages 88-89



NEUTRAL FURNITURE WITH DOORS AND DRAWERS



WALL COUNTERTOP

	Model	Dimensions	RRP (€)
RANGE 600	MNCC60-140M	1400x600x850	1.802
	MNCC60-160M	1600x600x850	1.876
	MNCC60-180M	1800x600x850	1.950
	MNCC60-200M	2000x600x850	2.054
	MNCC60-220M	2200x600x850	2.139
	MNCC60-240M	2400x600x850	2.231
RANGE 700	MNCC70-140M	1400x700x850	1.875
	MNCC70-160M	1600x700x850	1.986
	MNCC70-180M	1800x700x850	2.039
	MNCC70-200M	2000x700x850	2.124
	MNCC70-220M	2200x700x850	2.207
	MNCC70-240M	2400x700x850	2.287

CENTRAL COUNTERTOP

	Model	Dimensions	RRP (€)
RANGE 600	MNCC60-140C	1400x600x850	1.775
	MNCC60-160C	1600x600x850	1.849
	MNCC60-180C	1800x600x850	1.925
	MNCC60-200C	2000x600x850	2.033
	MNCC60-220C	2200x600x850	2.110
	MNCC60-240C	2400x600x850	2.196
RANGE 700	MNCC70-140C	1400x700x850	1.845
	MNCC70-160C	1600x700x850	1.954
	MNCC70-180C	1800x700x850	2.009
	MNCC70-200C	2000x700x850	2.100
	MNCC70-220C	2200x700x850	2.180
	MNCC70-240C	2400x700x850	2.258

WITHOUT COUNTERTOP

	Model	Dimensions	RRP (€)
RANGE 600	MNCC60-140	1400x600x850	1.511
	MNCC60-160	1600x600x850	1.565
	MNCC60-180	1800x600x850	1.618
	MNCC60-200	2000x600x850	1.701
	MNCC60-220	2200x600x850	1.753
	MNCC60-240	2400x600x850	1.814
RANGE 700	MNCC70-140	1400x700x850	1.554
	MNCC70-160	1600x700x850	1.643
	MNCC70-180	1800x700x850	1.672
	MNCC70-200	2000x700x850	1.735
	MNCC70-220	2200x700x850	1.786
	MNCC70-240	2400x700x850	1.835

Consult countertops on pages 88-89

NEUTRAL OPEN FURNITURE 600mm HIGH



WALL COUNTERTOP

	Model	Dimensions	RRP (€)
RANGE 600	MNAB60-60M	600x600x600	675
	MNAB60-80M	800x600x600	704
	MNAB60-100M	1000x600x600	737
	MNAB60-120M	1200x600x600	792
	MNAB60-140M	1400x600x600	852
	MNAB60-160M	1600x600x600	906
RANGE 700	MNAB70-60M	600x700x600	699
	MNAB70-80M	800x700x600	728
	MNAB70-100M	1000x700x600	762
	MNAB70-120M	1200x700x600	819
	MNAB70-140M	1400x700x600	883
	MNAB70-160M	1600x700x600	939

CENTRAL COUNTERTOP

	Model	Dimensions	RRP (€)
RANGE 600	MNAB60-60C	600x600x600	651
	MNAB60-80C	800x600x600	678
	MNAB60-100C	1000x600x600	711
	MNAB60-120C	1200x600x600	767
	MNAB60-140C	1400x600x600	825
	MNAB60-160C	1600x600x600	879
RANGE 700	MNAB70-60C	600x700x600	670
	MNAB70-80C	800x700x600	701
	MNAB70-100C	1000x700x600	734
	MNAB70-120C	1200x700x600	791
	MNAB70-140C	1400x700x600	853
	MNAB70-160C	1600x700x600	907

WITHOUT COUNTERTOP

	Model	Dimensions	RRP (€)
RANGE 600	MNAB60-60	600x600x600	442
	MNAB60-80	800x600x600	460
	MNAB60-100	1000x600x600	479
	MNAB60-120	1200x600x600	519
	MNAB60-140	1400x600x600	561
	MNAB60-160	1600x600x600	595
RANGE 700	MNAB70-60	600x700x600	443
	MNAB70-80	800x700x600	463
	MNAB70-100	1000x700x600	481
	MNAB70-120	1200x700x600	520
	MNAB70-140	1400x700x600	562
	MNAB70-160	1600x700x600	596

Consult countertops on pages 88-89

CORNER MODULE 90° WITH COUNTERTOP



Model MNEI60

- Straight edges to attach other countertops.
- It requires a cantilevered countertop, 600mm, on coupling lateral module.
- Possibility of integrating a key lock, model OCPB: 35€ (each door).

	Model	Dimensions	Corner	RRP (€)
RANGE 600	MNED60	1200x600x850	A derecha	1.032
	MNEI60	1200x600x850	A izquierda	1.032
RANGE 700	MNED70	1200x700x850	A derecha	1.071
	MNEI70	1200x700x850	A izquierda	1.071

ANGLE NEUTRAL MODULE WITH CHAMFERING AND COUNTERTOP



Model MNAC60

- Straight edges to attach other counters.

	Model	Dimensions	RRP (€)
	MNAC60	1000/1000x600x850	1.387
	MNAC70	1000/1000x700x850	1.431

SLIDES BODY MODULE



Consult countertops on pages 88-89

- 8 pairs of slides, 70mm apart.

	Model	Dimensions	Countertop	RRP (€)
RANGE 600	MNCG60GN-M	400x600x850	Wall	695
	MNCG60GN-C	400x600x850	Central	669
	MNCG60GN	400x600x850	Without	471
PASTRY SLIDES	MNCG60PS-M	600x600x850	Wall	722
	MNCG60PS-C	600x600x850	Central	698
	MNCG60PS	600x600x850	Without	489
RANGE 700	MNCG70GN-M	400x700x850	Wall	727
	MNCG70GN-C	400x700x850	Central	700
	MNCG70GN	400x700x850	Without	485
PASTRY SLIDES	MNCG70PS-M	600x700x850	Wall	759
	MNCG70PS-C	600x700x850	Central	730
	MNCG70PS	600x700x850	Without	503

BREAD SERVING UNIT MODULE

- Removable serving unit with integrated telescopic slides and brakes.

	Model	Dimensions	Corner	RRP (€)
RANGE 600	MNTP60M	600x600x850	Wall	948
	MNTP60C	600x600x850	Central	924
	MNTP60	600x600x850	Without countertop	715
RANGE 700	MNTP70M	600x700x850	Wall	993
	MNTP70C	600x700x850	Central	964
	MNTP70	600x700x850	Without countertop	737



WASTE UNIT MODULE

- Removable serving unit with integrated telescopic slides and brakes.
- Waste sack support.

	Model	Dimensions	Corner	RRP (€)
RANGE 600	MNTB60M	600x600x850	Wall	961
	MNTB60C	600x600x850	Central	937
	MNTB60	600x600x850	Without countertop	728
RANGE 700	MNTB70M	600x700x850	Wall	1.008
	MNTB70C	600x700x850	Central	979
	MNTB70	600x700x850	Without countertop	752



WASTE UNIT MODULE WITHOUT SHELF

- Capacity to hold a waste bin of up to Ø400mm.

	Model	Dimensions	Corner	RRP (€)
RANGE 600	MNSE60M	600x600x850	Wall	838
	MNSE60C	600x600x850	Central	814
	MNSE60	600x600x850	Without countertop	605
RANGE 700	MNSE70M	600x700x850	Wall	884
	MNSE70C	600x700x850	Central	855
	MNSE70	600x700x850	Without countertop	628



OPTIONAL WASTE DISPOSAL BORE ON COUNTERTOP

- Mechanized Ø 200mm bore on countertop.
- Removable rubber ring.

Model	For tables	RRP (€)
AAD-200	Countertop bore + rubber ring	73
AD-200	Rubber ring replacement	33



NEUTRAL CHEST OF DRAWERS

- Countertops manufactured of satin stainless steel AISI-304 18/10.
- Countertops with 100mm backsplash (on wall models) and 50mm rounded fronts, entirely welded.
- Countertops and shelves with omegas reinforcement.
- Removable drawers with incorporated telescopic slides with brakes.
- Each drawer can hold a well GN 1/1 100 or up to 200, depending on the model.
- Robust legs, height adjustable by unseen screws.
- Modular furniture easily integrated to any other modular neutral elements by means of common or independent countertop.
- Possibility of integrating a key lock on each drawer, model OCPB: 35€ (per drawer).

NEUTRAL CHEST OF DRAWERS MODULE - 4 DRAWERS



	Model	Dimensions	Corner	RRP (€)
RANGE 600	MNC4-60M	400x600x850	Wall	970
	MNC4-60C	400x600x850	Central	944
	MNC4-60	400x600x850	Without countertop	746

	Model	Dimensions	Corner	RRP (€)
RANGE 700	MNC4-70M	400x700x850	Wall	1.006
	MNC4-70C	400x700x850	Central	979
	MNC4-70	400x700x850	Without countertop	764

NEUTRAL CHEST OF DRAWERS MODULE - 2 DRAWERS



	Model	Dimensions	Corner	RRP (€)
RANGE 600	MNC2-60M	400x600x850	Wall	836
	MNC2-60C	400x600x850	Central	810
	MNC2-60	400x600x850	Without countertop	612

	Model	Dimensions	Corner	RRP (€)
RANGE 700	MNC2-70M	400x700x850	Wall	863
	MNC2-70C	400x700x850	Central	836
	MNC2-70	400x700x850	Without countertop	621

Consult countertops on pages 88-89

NEUTRAL CHEST OF DRAWERS MODULE - 3 DRAWERS

	Model	Dimensions	Corner	RRP (€)
RANGE 600	MNC31-60M	400x600x850	Wall	878
	MNC31-60C	400x600x850	Central	852
	MNC31-60	400x600x850	Without countertop	654

	Model	Dimensions	Corner	RRP (€)
RANGE 700	MNC31-70M	400x700x850	Wall	909
	MNC31-70C	400x700x850	Central	882
	MNC31-70	400x700x850	Without countertop	667

	Model	Dimensions	Corner	RRP (€)
RANGE 600	MNC32-60M	400x600x850	Wall	878
	MNC32-60C	400x600x850	Central	852
	MNC32-60	400x600x850	Without countertop	654

	Model	Dimensions	Corner	RRP (€)
RANGE 700	MNC32-70M	400x700x850	Wall	909
	MNC32-70C	400x700x850	Central	882
	MNC32-70	400x700x850	Without countertop	667

	Model	Dimensions	Corner	RRP (€)
RANGE 600	MNC33-60M	400x600x850	Wall	836
	MNC33-60C	400x600x850	Central	810
	MNC33-60	400x600x850	Without countertop	612

	Model	Dimensions	Corner	RRP (€)
RANGE 700	MNC33-70M	400x700x850	Wall	909
	MNC33-70C	400x700x850	Central	882
	MNC33-70	400x700x850	Without countertop	667

Consult countertops on pages 88-89



HOT TABLES WITH SLIDING DOORS

- Countertops manufactured of satin stainless steel AISI-304 18/10.
- Countertops with 100mm backsplash (on wall models) and 50mm rounded fronts, entirely welded.
- Countertops and shelves with omegas reinforcement.
- Inner heating by means of easily removable ventilated resistances.
- Control panel with illuminated switch and adjustable digital thermometer/thermostat.
- Security thermal protection by means of klixon.
- Maximum energetic efficiency thanks to the double wall and fibreglass integral insulation, in the case as well as the doors.
- Suspended sliding doors of smooth slide by means of rail with ball bearing.
- Robust legs, height adjustable by unseen screws.
- Modular furniture easily integrated to any other modular neutral elements by means of common or independent countertop.
- Operating power 230V single-phase, 50 Hz.

HOT TABLES CROSSING OPEN



CENTRAL COUNTERTOP

	Model	Dimensions	Power	RRP (€)
RANGE 600	MCAP60-120C	1200x600x850	2100 W	1.892
	MCAP60-160C	1600x600x850	2100 W	2.285
	MCAP60-180C	1800x600x850	2600 W	2.609

	Model	Dimensions	Power	RRP (€)
RANGE 700	MCAP70-120C	1200x700x850	2100 W	2.041
	MCAP70-160C	1600x700x850	2600 W	2.429
	MCAP70-180C	1800x700x850	3100 W	2.691
	MCAP70-200C	2000x700x850	3100 W	2.955
	MCAP70-225C	2250x700x850	3100 W	3.221

WITHOUT COUNTERTOP

	Model	Dimensions	Power	RRP (€)
RANGE 600	MCAP60-120	1200x600x850	2100 W	1.644
	MCAP60-160	1600x600x850	2100 W	2.001
	MCAP60-180	1800x600x850	2600 W	2.302

	Model	Dimensions	Power	RRP (€)
RANGE 700	MCAP70-120	1200x700x850	2100 W	1.770
	MCAP70-160	1600x700x850	2600 W	2.118
	MCAP70-180	1800x700x850	3100 W	2.354
	MCAP70-200	2000x700x850	3100 W	2.590
	MCAP70-225	2250x700x850	3100 W	2.800

Consult countertops on pages 88-89

HOT TABLES WITH DOORS AND STAINLESS STEEL BACKREST

WALL COUNTERTOP

	Model	Dimensions	Power	RRP (€)
RANGE 600	MCA60-120M	1200x600x850	2100 W	1.712
	MCA60-160M	1600x600x850	2100 W	2.086
	MCA60-180M	1800x600x850	2600 W	2.276

	Model	Dimensions	Power	RRP (€)
RANGE 700	MCA70-120M	1200x700x850	2100 W	1.761
	MCA70-160M	1600x700x850	2600 W	2.121
	MCA70-180M	1800x700x850	3100 W	2.476
	MCA70-200M	2000x700x850	3100 W	2.707
	MCA70-225M	2250x700x850	3100 W	2.905



CENTRAL COUNTERTOP

	Model	Dimensions	Power	RRP (€)
RANGE 600	MCA60-120C	1200x600x850	2100 W	1.687
	MCA60-160C	1600x600x850	2100 W	2.059
	MCA60-180C	1800x600x850	2600 W	2.251

	Model	Dimensions	Power	RRP (€)
RANGE 700	MCA70-120C	1200x700x850	2100 W	1.733
	MCA70-160C	1600x700x850	2600 W	2.089
	MCA70-180C	1800x700x850	3100 W	2.446
	MCA70-200C	2000x700x850	3100 W	2.683
	MCA70-225C	2250x700x850	3100 W	2.878



WITHOUT COUNTERTOP

	Model	Dimensions	Power	RRP (€)
RANGE 600	MCA60-120	1200x600x850	2100 W	1.439
	MCA60-160	1600x600x850	2100 W	1.775
	MCA60-180	1800x600x850	2600 W	1.944

	Model	Dimensions	Power	RRP (€)
RANGE 700	MCA70-120	1200x700x850	2100 W	1.462
	MCA70-160	1600x700x850	2600 W	1.778
	MCA70-180	1800x700x850	3100 W	2.109
	MCA70-200	2000x700x850	3100 W	2.318
	MCA70-225	2250x700x850	3100 W	2.484

Consult countertops on pages 88-89



BEIN MARIE WARMERS

- Countertops manufactured of satin stainless steel AISI-304 18/10.
- Countertops with 50mm rounded fronts, entirely welded.
- Embedded well with sanitary rounded corners for wells GN of up to 150mm deep (humid models) or 200mm (dry models). Trays not included.
- Adjustable well temperature +50°C/+90°C.
- Insulation by means of fireproof ecological polyurethane.
- Suspended sliding doors of smooth slide by means of rail with ball bearing.
- Robust legs, height adjustable by unseen screws.
- Control panel with illuminated switch and adjustable digital

- thermometer/thermostat and security thermal protection.
- Single-phase 230V/50 Hz (except for modules MBMN-225 and MBMR-225: three-phase 400V/50Hz).

Models with heated reserve:

- Interior heating by means of easily removable ventilated resistances.
- Maximum energetic efficiency thanks to the double wall and fibreglass integral insulation, in the case as well as the doors.
- Control panel with illuminated switch and adjustable digital thermometer/thermostat with security thermal protection.

HUMID BEIN MARIE WARMERS

- Well heating by means of silicone resistances that improve and reduce the electric consumption.
- Inlet taps and integrated drainage 1/2", with ball valve mechanism and removable spillway tube.

NEUTRAL RESERVE HUMID BEIN-MARIE WARMER



Model	Trays	Dimensions	Power	RRP (€)
MBMN-120	3 GN 1/1-200	1200x700x850	2000 W	2288
MBMN-160	4 GN 1/1-200	1600x700x850	3000 W	2683
MBMN-200	5 GN 1/1-200	2000x700x850	3000 W	3297
MBMN-225	6 GN 1/1-200	2250x700x850	4000 W	3689

HEATED RESERVE HUMID BEIN-MARIE WARMER



Model	Trays	Dimensions	Power	RRP (€)
MBMR-120	3 GN 1/1-200	1200x700x850	4100 W	2466
MBMR-160	4 GN 1/1-200	1600x700x850	5100 W	2803
MBMR-200	5 GN 1/1-200	2000x700x850	5600 W	3657
MBMR-225	6 GN 1/1-200	2250x700x850	6600 W	3788

DRY BEIN MARIE WARMERS

- Well heating by means of sealed resistances, protected by grilled double bottom and easily removable for its cleanness.

NEUTRAL RESERVE DRY BEIN-MARIE WARMER



Model	Trays	Dimensions	Power	RRP (€)
MBSN-120	3 GN 1/1-150	1200x700x850	2000 W	2223
MBSN-160	4 GN 1/1-150	1600x700x850	2500 W	2618
MBSN-200	5 GN 1/1-150	2000x700x850	3000 W	3232
MBSN-225	6 GN 1/1-150	2250x700x850	3000 W	3624

HEATED RESERVE DRY BEIN-MARIE WARMER



Model	Trays	Dimensions	Power	RRP (€)
MBSR-120	3 GN 1/1-150	1200x700x850	4100 W	2401
MBSR-160	4 GN 1/1-150	1600x700x850	4600 W	2737
MBSR-200	5 GN 1/1-150	2000x700x850	5600 W	3592
MBSR-225	6 GN 1/1-150	2250x700x850	5600 W	3722

TABLETOP BEIN-MARIE WARMERS

- Manufactured of stainless steel AISI-304 18/10.
- Entirely welded well, with rounded sanitary edges.
- Insulation by means of fireproof ecological polyurethane.
- Designed for GN wells of up to 150mm deep (not included).
- Adjustable well temperature +50°C/+90°C.

- Drainage faucet with ball valve mechanism.
- Control panel with illuminated switch and digital thermometer/thermostat.
- Security thermal protection by means of klixon.
- Operating power 230V single-phase, 50 Hz.

TOPTABLE HUMID BEIN-MARIE

- Well heating by means of silicone resistances that improve and reduce the electric consumption.
- Designed for GN wells of up to 150mm deep (not included).
- Integrated drainage 1/2", with ball valve mechanism and removable spillway tube



Model	Dimensions	Trays	Power	RRP (€)
BMMH-2GN	790x650x270	2 GN 1/1-150	1000 W	782
BMMH-3GN	1120x650x270	3 GN 1/1-150	2000 W	997

TOPTABLE HUMID BEIN-MARIE

- Well heating by means of shielded resistances protected by grilled double bottom, removable for a better cleaning.
- Designed for GN wells of up to 100mm deep (not included).



Model	Dimensions	Trays	Power	RRP (€)
BMMS-2GN	790x650x270	2 GN 1/1-100	800 W	613
BMMS-3GN	1120x650x270	3 GN 1/1-100	1200 W	775

BEIN-MARIE TROLLEYS

- Manufactured of stainless steel AISI-304 18/10.
- Entirely welded well, with sanitary rounded edges.
- Insulation by means of fireproof ecological polyurethane.
- Adjustable operating temperature +50°C/+90°C.
- Control panel with illuminated switch and digital thermometer/thermostat.
- Security thermal protection by means of klixon.
- Operating power 230V single-phase, 50 Hz.
- 4 swivelling wheels, two of them with brakes.
- Lower shelf included.



HUMID BEIN-MARIE TROLLEY

- Well heating by means of silicone resistances that improve and reduce the electric consumption.
- Designed for GN wells of up to 150mm deep (not included).
- Integrated drainage 1/2", with ball valve mechanism and removable spillway tube

Model	Dimensions	Trays	Power	RRP (€)
CBMH-2GN	790x690x945	2 GN 1/1-150	1000 W	1.483
CBMH-3GN	1120x690x945	3 GN 1/1-150	2000 W	1.747
CBMH-4GN	1445x690x945	4 GN 1/1-150	3000 W	2.144
CBMH-5GN	1770x690x945	5 GN 1/1-150	3000 W	2.566

DRY BEIN-MARIE TROLLEY

- Well heating by means of shielded resistances protected by grilled double bottom, removable for a better cleaning.
- Designed for GN wells of up to 100mm deep (not included).

Model	Dimensions	Trays	Power	RRP (€)
CBMS-2GN	790x690x945	2 GN 1/1-100	800 W	1.351
CBMS-3GN	1120x690x945	3 GN 1/1-100	1200 W	1.503
CBMS-4GN	1445x690x945	4 GN 1/1-100	1600 W	1.868
CBMS-5GN	1770x690x945	5 GN 1/1-100	2000 W	2.279

TALL CABINETS

- Manufactured of satin stainless steel AISI-304 18/10.
- Intermediate shelves adjustable in height by means of highly resistant support.

- Shelves with omegas reinforcement.
- Robust legs, height adjustable by unseen screws.
- Integrated key lock.

TALL CABINET WITH SLIDING DOORS

- Suspended sliding doors of smooth slide by means of rail with ball bearing.

Model	Dimensions	Doors	RRP (€)
APC-120	1200x600x1900	Sliding	1.795
APC-140	1400x600x1900	Sliding	1.941
APC-160	1600x600x1900	Sliding	2.092

TALL CABINET WITH HINGED DOORS

- Hinged doors with 3 hinges and magnetic lock.

Model	Dimensions	Doors	RRP (€)
APB-60	600x600x1900	Hinged	1.065
APB-100	1000x600x1900	Hinged	1.529
APB-120	1200x600x1900	Hinged	1.734
APB-140	1400x600x1900	Hinged	1.836



CLEANERS CABINETS

- Manufactured of satin stainless steel AISI-304 18/10.
- Highly resistant shelves.
- Hinged doors with 3 hinges and magnetic lock.
- Robust legs, height adjustable by unseen screws.
- Integrated key lock.

Model	Dimensions	Doors	RRP (€)
APL-60	600x450x1900	One door	1.076
APL-100	1000x450x1900	Two doors	1.357



TILTED PROTECTION FOR CABINET TOPS

- Easy instalment with screw included.

Model	Dimensions	RRP (€)
PI45-60	600x450	78
PI45-100	1000x450	98
PI60-60	600x600	91
PI60-100	1000x600	102
PI60-120	1200x600	113
PI60-140	1400x600	141
PI60-160	1600x600	160



OPEN WALL CABINET

- Manufactured of satin stainless steel AISI-304 18/10.
- Reinforced intermediate shelf, adjustable in height.
- Sturdy wall anchor, easy to install by means of screw included.

Model	Dimensions	RRP (€)
APA-100	1000x400x600	518
APA-120	1200x400x600	579
APA-140	1400x400x600	639
APA-160	1600x400x600	708



SLIDING DOORS WALL CABINETS

- Manufactured of satin stainless steel AISI-304 18/10.
- Reinforced intermediate shelf, adjustable in height.
- Suspended sliding doors of smooth slide by means of rail with ball bearing.
- Sturdy wall anchor, easy to install by means of screw included.

Model	Dimensions	RRP (€)
AP-100	1000x400x600	642
AP-120	1200x400x600	716
AP-140	1400x400x600	836
AP-160	1600x400x600	881



SLIDING DOORS WALL CABINETS AND PLATE RACKS

- Manufactured of satin stainless steel AISI-304 18/10.
- Reinforced intermediate shelf, adjustable in height.
- Interior plates rack.
- Designed for plates of up to Ø300mm.
- Suspended sliding doors of smooth slide by means of rail with ball bearing.
- Sturdy wall anchor, easy to install by means of screw included.

Model	Dimensions	RRP (€)
AP-100 E	1000x400x600	726
AP-120 E	1200x400x600	765



CORNER WALL CABINET

- Manufactured of satin stainless steel AISI-304 18/10.
- Hinged door with magnetic lock.
- Reinforced intermediate shelf, adjustable in height.
- Sturdy wall anchors, easy to install by means of screw included.

Model	Dimensions	RRP (€)
APR-70	700x700x600	926



COUNTERTOPS FOR FURNITURE

- Manufactured of satin stainless steel AISI-304 18/10.
- Countertops with 100mm backsplash (on wall models) and 50mm rounded fronts, entirely welded.
- Reinforced and soundproof by omegas.
- They are easily installed to assemble any modular composition.
- They can perfectly integrate different neutral or cold modular elements.
- Possibility of manufacturing according to customized measurements.
- Option of waste bore on countertop, see page 79.
- Option of well on countertop, see page 55.



DOUBLE CENTRAL COUNTERTOPS

	Model	Dimensions	RRP (€)		Model	Dimensions	RRP (€)
RANGE 1200	EC120-140	1400x1200	583	RANGE 1300	EC130-140	1400x1300	612
	EC120-160	1600x1200	621		EC130-160	1600x1300	653
	EC120-180	1800x1200	666		EC130-180	1800x1300	699
	EC120-200	2000x1200	707		EC130-200	2000x1300	743
	EC120-220	2200x1200	772		EC130-220	2200x1300	808
	EC120-240	2400x1200	834		EC130-240	2400x1300	870
	EC120-260	2600x1200	896		EC130-260	2600x1300	927
	EC120-280	2800x1200	959		EC130-280	2800x1300	992

SPECIAL MEASUREMENTS. CONSULT PRICES.

WALL COUNTERTOPS



	Model	Dimensions	RRP (€)		Model	Dimensions	RRP (€)
RANGE 600	EM60-40	400x600	224	RANGE 700	EM70-40	400x700	242
	EM60-60	600x600	233		EM70-60	600x700	256
	EM60-80	800x600	244		EM70-80	800x700	265
	EM60-100	1000x600	258		EM70-100	1000x700	281
	EM60-120	1200x600	273		EM70-120	1200x700	299
	EM60-140	1400x600	291		EM70-140	1400x700	321
	EM60-160	1600x600	311		EM70-160	1600x700	343
	EM60-180	1800x600	332		EM70-180	1800x700	367
	EM60-200	2000x600	353		EM70-200	2000x700	389
	EM60-220	2200x600	386		EM70-220	2200x700	421
	EM60-240	2400x600	417		EM70-240	2400x700	452
	EM60-260	2600x600	447		EM70-260	2600x700	479
EM60-280	2800x600	479	EM70-280	2800x700	512		
EM60-300	3000x600	510	EM70-300	3000x700	547		

CENTRAL COUNTERTOPS



	Model	Dimensions	RRP (€)		Model	Dimensions	RRP (€)
RANGE 600	EC60-40	400x600	198	RANGE 700	EC70-40	400x700	215
	EC60-60	600x600	209		EC70-60	600x700	227
	EC60-80	800x600	218		EC70-80	800x700	238
	EC60-100	1000x600	232		EC70-100	1000x700	253
	EC60-120	1200x600	248		EC70-120	1200x700	271
	EC60-140	1400x600	264		EC70-140	1400x700	291
	EC60-160	1600x600	284		EC70-160	1600x700	311
	EC60-180	1800x600	307		EC70-180	1800x700	337
	EC60-200	2000x600	332		EC70-200	2000x700	365
	EC60-220	2200x600	357		EC70-220	2200x700	394
	EC60-240	2400x600	382		EC70-240	2400x700	423
	EC60-260	2600x600	408		EC70-260	2600x700	452
EC60-280	2800x600	437	EC70-280	2800x700	485		
EC60-300	3000x600	468	EC70-300	3000x700	520		

SPECIAL MEASUREMENTS. CONSULT PRICES.

ERATOS furniture is supplied with legs adjustable in height by means of unseen screw. Optionally, they can also be supplied with decorating plinths, wheels or with straight base for their placement on brick bases or plinths.

ERATOS. CATALOG 2020

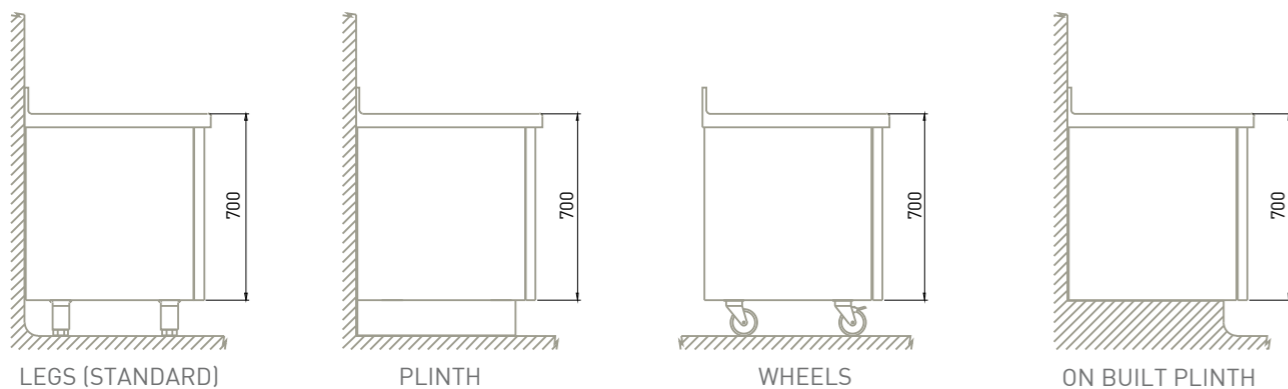

PLINTHS

- Manufactured of stainless steel AISI-304 18/10.
- Easy to install.



Model	Type	Dimensions	RRP (€)
SZ-40	Front	400x100x135	58
SZ-60	Front	600x100x135	74
SZ-80	Front	800x100x135	92
SZ-100	Front	1000x100x135	126
SZ-120	Front	1200x100x135	142
SZ-140	Front	1400x100x135	155
SZ-160	Front	1600x100x135	189
SZ-180	Front	1800x100x135	224
SZ-200	Front	2000x100x135	261
SZ-220	Front	2200x100x135	323
SZ-240	Front	2400x100x135	342
ZL-60	Lateral 600	348x100x135	80
ZL-70	Lateral 700	448x100x135	82

WHEELS KIT

- Ø125mm wheels.
- Two wheels with brakes are supplied in each kit.



For furniture	Model	Nº of wheels	RRP (€)
≤ 2000 mm	KRM4	4	192
> 2000 mm	KRM6	6	288

EXAMPLES OF MODULAR COMPOSITIONS



Model	Description	RRP (€)
MCA70-120	Heated table without countertop. Measurements 1200x700x850mm	1.462
MNC33-70	Furniture with 2 simple and 1 double drawers without countertop. Measurements: 400x700x850mm	667
MNCG70GN	Furniture with slides GN1/1, without countertop. Measurements: 1000x700x850mm	485
MNB70-100	Hinged doors furniture, without countertop. Measurements: 1000x700x850mm	863
EC70-300	Wall countertop. Measurements: 3000x700mm	520



Model	Description	RRP (€)
MNC70-120	Table with sliding doors, without countertop. Measurements: 1200x700x850mm	879
MNC4-70	Furniture with 4 drawers, without countertop. Measurements: 400x700x850mm	764
MNED70	Corner module 90°, with right countertop. Measurements: 1200x700x850mm	1.071
MNA70-100M	Open furniture, with wall countertop. Measurements: 1000x700x850mm	817
EM70-280	Wall countertop. Measurements: 2800x700mm	485
AAD-200	Bore on countertop and removable waste ring.	73
CC-100	Waste bin 100 litres without pedal. Measurements: Ø450x685mm	210

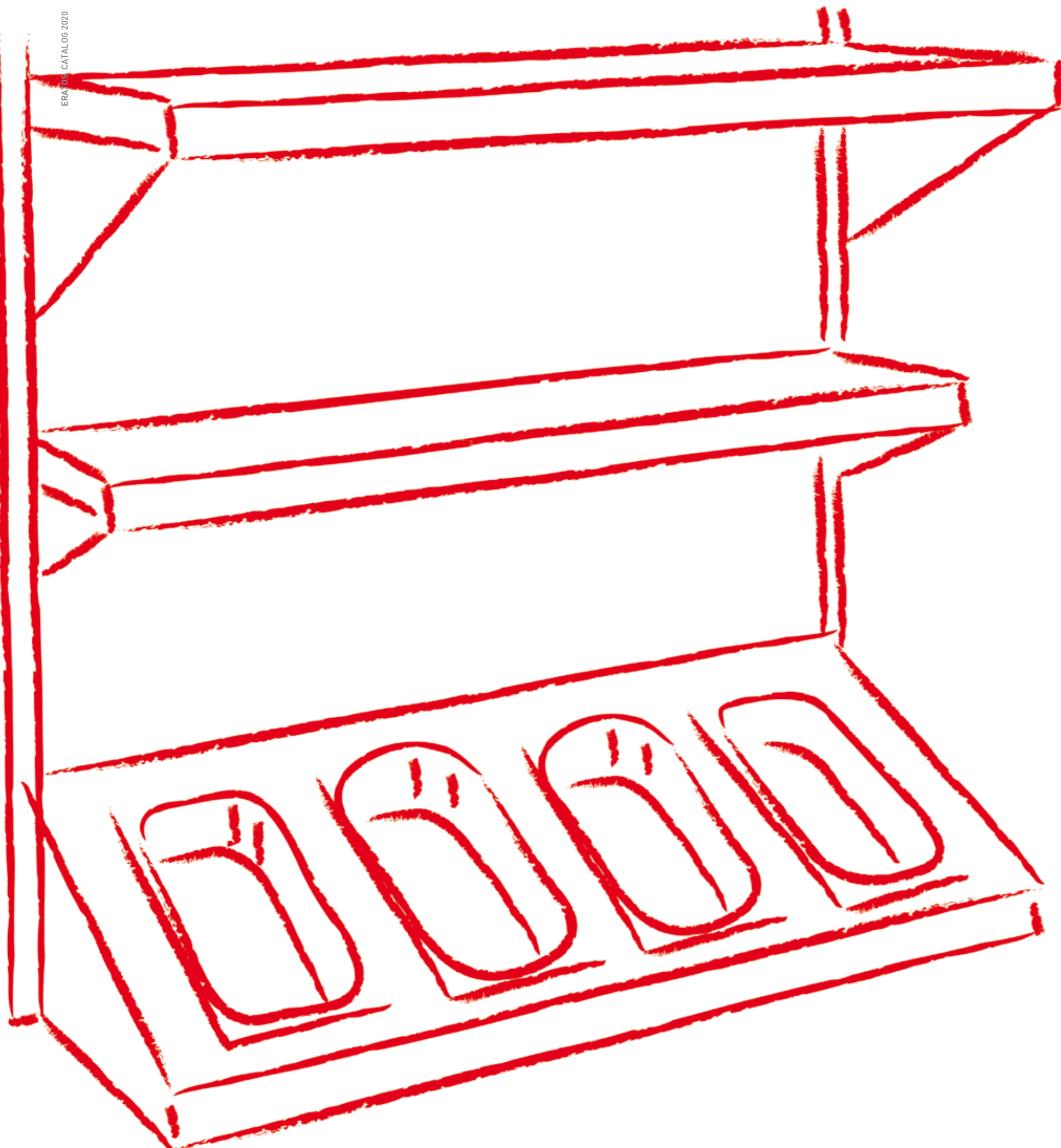

SHELVING UNITS

- Stainless steel and polypropylene shelving units page 94
- Shelving units height 1800mm – depth 400 mm page 96
- Shelving units height 1800mm – depth 500 mm page 96
- Shelving units height 2100mm – depth 400 mm page 96
- Shelving units height 2100mm – depth 500 mm page 96
- Adjustable wall shelving unit page 100
- Microwave shelf page 100
- Hanging bar page 100
- Wall shelving units page 101
- Tabletop shelving units page 102
- Heat/lamp strips page 103
- Stainless steel tall shelving units page 103

STAINLESS STEEL AND POLYPROPYLENE SHELVING UNITS

- Stainless steel and polypropylene shelving units with excellent quality-price ratio, designed for perfect adaptation to all refrigeration, catering and food industry thanks to their performance and constructive characteristics.
- Anodized aluminium structure and polypropylene grilles.
- Adjustable in height every 150mm.



Quality and hygiene

Robust, hygienic and long-lasting shelving units, with rack ladders structure and crossbars manufactured of anodized aluminium and removable high-density polypropylene grilles.



Easy to assemble

Shelving units designed with a quick, easy and intuitive assembly system, which does not require qualified staff, screws or tools. Once assembled, it acquires a solid, resistant performance.



Modularity

Modular shelving units without lineal-angle setting limits and with up to 10 levels of shelves. Adjustable height feet by means of unsewn screw and optional wheels.



Performance

Our shelving units can be in direct contact with food. They support temperatures of -30° to +75°C and distributed loads of 100 kg/m or punctual loads of 120 kg/shelf.

COMPLETE SHELVES

- They include crossbars, grilles and anchor.



	Model	Dimensions (mm)	RRP (€)		Model	Dimensions (mm)	RRP (€)
RANGE 400	AL-21	686x400	37,7	RANGE 500	AL-13	686x500	40,5
	AL-22	798x400	42,0		AL-14	798x500	45,1
	AL-23	910x400	46,1		AL-15	910x500	49,7
	AL-24	1029x400	52,3		AL-16	1029x500	56,4
	AL-25	1141x400	56,5		AL-17	1141x500	61,0
	AL-26	1253x400	61,0		AL-18	1253x500	65,8
	AL-27	1365x400	65,8		AL-19	1365x500	70,9
	AL-28	1481x400	72,0		AL-20	1481x500	78,9
	AL-29	1593x400	75,9		AL-30	1593x500	86,4

RACK LADDERS

	Model	Dimensions (mm)	RRP (€)
RANGE 400	AL-01	1800x400	65,2
	AL-11	2100x400	91,9
RANGE 500	AL-02	1800x500	65,7
	AL-12	2100x500	92,5

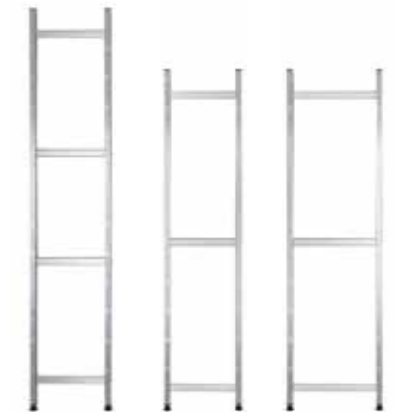

MOUNTING ANGLE

- This accessory is for each shelf.

Model	Depth (mm)	RRP (€)
AL-31	400	9,9
AL-32	500	9,9



SHELF SUPPORT ANCHOR

- Single, 4 units/shelf.

Model	Type	RRP (€)
AL-61	Staright	1,3 (und)
AL-62	Angle	1,3 (und)



WHEELS

Model	Type	RRP (€)
AL-81	With brake	34,3
AL-82	Without brake	38,9



FLOOR BENCHES



	Model	Dimensions (mm)	RRP (€)		Model	Dimensions (mm)	RRP (€)
RANGE 400	BS-01	744x400x200	80,3	RANGE 500	BS-10	744x500x200	83,2
	BS-02	856x400x200	84,4		BS-11	856x500x200	87,8
	BS-03	968x400x200	88,6		BS-12	968x500x200	92,4
	BS-04	1087x400x200	94,6		BS-13	1087x500x200	99,0
	BS-05	1099x400x200	98,8		BS-14	1199x500x200	103,5
	BS-06	1311x400x200	103,2		BS-15	1311x500x200	108,4
	BS-07	1423x400x200	108,0		BS-16	1423x500x200	113,4
	BS-08	1539x400x200	113,2		BS-17	1539x500x200	119,3
	BS-09	1651x400x200	117,7		BS-18	1651x500x200	124,2

ADJUSTABLE WALL SHELVING UNIT

- Manufactured of stainless steel AISI-304 18/10.
- Easy horizontal and vertical enlargement thanks to its slotted side stands.
- Easily removable and height adjustable shelves.
- Quick and easy to assemble (screws and plugs included).



GASTRONORM containers not included

SIDE STANDS

Model	Dimensions	RRP (€/Ud.)
MM-60	600	25
MM-100	1000	30
MM-150	1500	40

PLAIN SHELVES

Model	Dimensions	RRP (€)
RANGE 250 EMR25-100	1000x250	76
EMR25-120	1200x250	98
EMR25-140	1400x250	105
EMR25-160	1600x250	136

RANGE 400 EMR40-100	1000x400	108
EMR40-120	1200x400	136
EMR40-140	1400x400	150
EMR40-160	1600x400	195

TILTED SHELVES

Model	Wells	Dimensions	RRP (€)
EMR125-100	4 - 1/6 GN	1000x250	91
EMR140-100	4 - 1/3 GN	1000x400	130

WALL MICROWAVE SHELF



- Manufactured of stainless steel AISI-304 18/10.
- It includes lead-through hole.
- Quick and easy to assemble (screws and plugs included)

Model	Dimensions	RRP (€)
EMM40-60	600x400	165
EMM55-60	600x550	191

HANGING BAR



- Solid and robust, manufactured of stainless steel AISI-304 18/10 tube.
- Quick and easy to assemble (screws and plugs included).

Model	Dimensions	RRP (€)
BC-10	1000x200	110
BC-15	1500x200	135
BC-20	2000x200	143

PLAIN WALL SHELF

NEW DESIGN

- Solid and robust, manufactured of satin stainless steel AISI-304 18/10.
- New, more solid and reinforced design.
- Utterly welded corners.
- Quick and easy to assemble (screws and plugs included).

Model	Dimensions	RRP (€)
RANGE 250 EML25-60	600x250	102
EML25-80	800x250	106
EML25-100	1000x250	115
EML25-120	1200x250	130
EML25-140	1400x250	144
EML25-150	1500x250	146
EML25-160	1600x250	149
EML25-180	1800x250	172
EML25-200	2000x250	194



Model	Dimensions	RRP (€)
RANGE 400 EML40-60	600x400	127
EML40-80	800x400	131
EML40-100	1000x400	146
EML40-120	1200x400	158
EML40-140	1400x400	174
EML40-150	1500x400	184
EML40-160	1600x400	192
EML40-180	1800x400	211
EML40-200	2000x400	233



TUBULAR WALL SHELF

- Solid and robust, manufactured of stainless steel AISI-304 18/10.
- Quick and easy to assemble (screws and plugs included).

Model	Dimensions	RRP (€)
EMT40-100	1000x400	190
EMT40-120	1200x400	196
EMT40-140	1400x400	216
EMT40-160	1600x400	229
EMT40-180	1800x400	272
EMT40-200	2000x400	290



EXTRACTOR HOOD WALL SHELF

- Manufactured of stainless steel AISI-304 18/10.
- Easily removable grilles to facilitate their cleaning.
- Quick and easy to assemble (screws and plugs included).

Model	Dimensions	RRP (€)
EMC-1GN	585x380	263
EMC-2GN	1115x380	324
EMC-3GN	1650x380	375
EMC-4GN	2180x380	423



TABLETOP SHELVES

- Manufactured of satin stainless steel AISI-304 18/10.
- Easy and quick installation by means of small bores on the countertop (Assembly Instructions Manual included).
- Ø30 mm rounded tube legs.
- They can be attached to any other mounted tables.
- They can be equipped with lamp strip or heat lamp strip (not included).



DISMOUNTED

Model	Dimensions	RRP (€)	Model	Dimensions	RRP (€)
ESD-71	700x350x400	259	ESD-72	700x350x700	356
ESD-91	900x350x400	263	ESD-92	900x350x700	363
ESD-111	1100x350x400	266	ESD-112	1100x350x700	369
ESD-131	1300x350x400	274	ESD-132	1300x350x700	379
ESD-151	1500x350x400	289	ESD-152	1500x350x700	409
ESD-171	1700x350x400	303	ESD-172	1700x350x700	448
ESD-191	1900x350x400	317	ESD-192	1900x350x700	462
ESD-211	2100x350x400	352	ESD-212	2100x350x700	518

WELDED

Model	Dimensions	RRP (€)	Model	Dimensions	RRP (€)
ES-71	700x350x400	306	ES-72	700x350x700	403
ES-91	900x350x400	310	ES-92	900x350x700	410
ES-111	1100x350x400	313	ES-112	1100x350x700	416
ES-131	1300x350x400	339	ES-132	1300x350x700	444
ES-151	1500x350x400	355	ES-152	1500x350x700	475
ES-171	1700x350x400	368	ES-172	1700x350x700	513
ES-191	1900x350x400	401	ES-192	1900x350x700	546
ES-211	2100x350x400	436	ES-212	2100x350x700	602

Example of assembled shelves with lamp strip and heat lamp strip, see following page.



LAMP STRIP AND HEAT LAMP STRIP

NEW DESIGN

- Manufactured of satin stainless steel AISI-304 18/10.
- Illuminated switch.
- The halogen bulbs integrate glass protection.
- Easy and quick installation.

HEAT LAMP STRIP WITH HALOGEN BULBS

- Strip designed to keep products warm and illuminated.
- The heat and light is realized by means of high power halogen bulbs.

Model	Dimensions	Nº of Lamps	Power	RRP (€)
PL-80	800x150x60	2	600 W	427
PL-120	1200x150x60	3	900 W	471
PL-160	1600x150x60	4	1200 W	513

HALOGEN BULBS LAMP STRIP WITH CERAMIC HEAT

- Strip designed to keep products warm and illuminated.
- It offers a higher intensity of heat thanks to the ceramic elements that provide intense and more concentrated heat. The illumination is produced by means of halogen bulbs and the heat produced by ceramic resistances tile type.

Model	Dimensions	Nº of Lamps and Resistances	Power	RRP (€)
PLC-80	800x150x60	2+2	890 W	603
PLC-120	1200x150x60	3+2	1210 W	666
PLC-160	1600x150x60	4+3	1530 W	796

LAMP STRIP WITH CERAMIC HEAT

- Strip designed to keep products warm.
- It offers a higher intensity of heat thanks to the ceramic elements that provide intense and more concentrated heat.

Model	Dimensions	Nº of Resistances	Power	RRP (€)
PCC-80	800x150x60	2	750 W	465
PCC-120	1200x150x60	3	1000 W	528
PCC-160	1600x150x60	4	1250 W	589

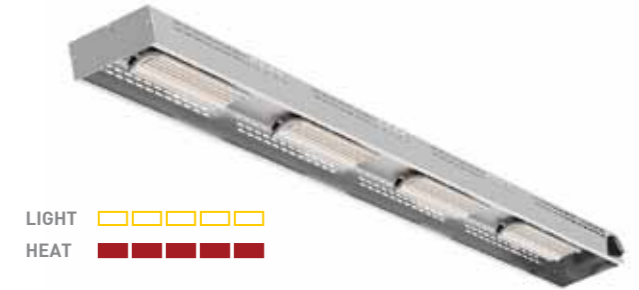
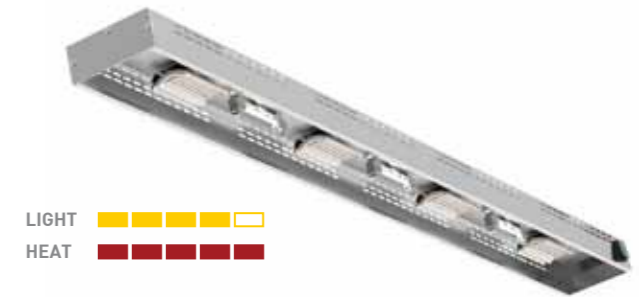
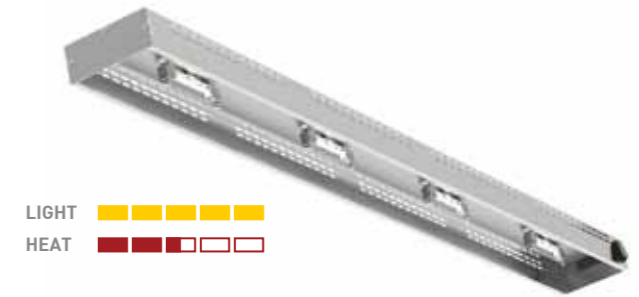

TALL DISMOUNTABLE SHELVING UNIT

Model	Dimensions	RRP (€)
EI18-85	800x500x1800	356
EI18-105	1000x500x1800	372
EI18-125	1200x500x1800	428
EI18-145	1400x500x1800	484

- Utterly manufactured of satin stainless steel AISI-304 18/10.
- The unit is composed of 4 shelves and 4 side stands.
- Shelves adjustable in height every 150mm.
- They are supplied with plastic feet.
- Easy to assemble by means of screws (screws included).

Model	Dimensions	RRP (€)
EI20-85	800x500x2000	384
EI20-105	1000x500x2000	400
EI20-125	1200x500x2000	456
EI20-145	1400x500x2000	512

ADDITIONAL SHELVES

- Easy to assemble by means of screws (screws included).

Model	Dimensions	RRP (€)
EE-85	800x500	56
EE-105	1000x500	60
EE-125	1200x500	74
EE-145	1400x500	88



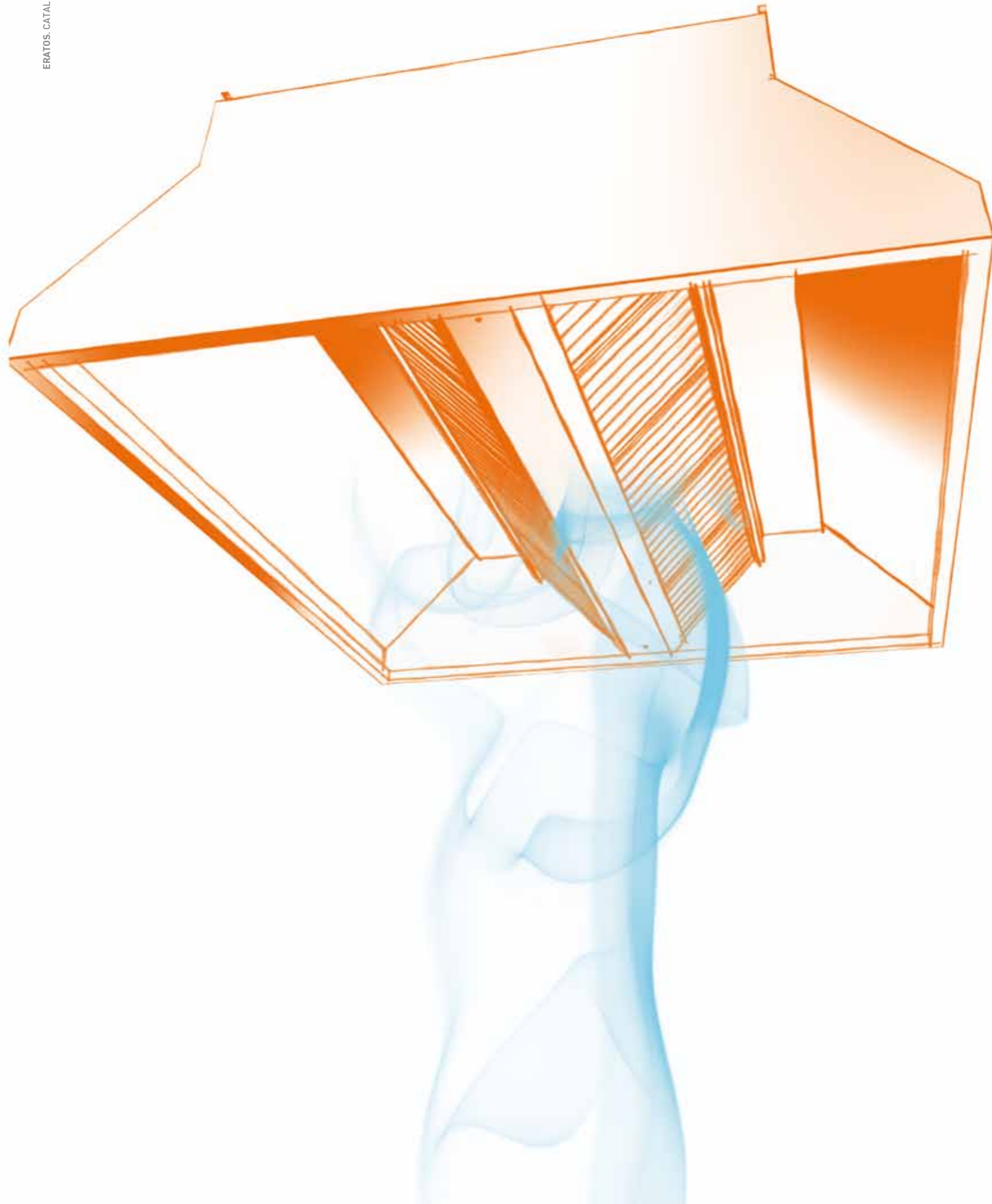

EXTRACTOR CANOPIES

Snack low wall extractor canopies	page 107
Snack straight wall extractor canopies	page 107
Snack wall extractor canopies series 80	page 108
Snack wall extractor canopies series 95	page 109
Snack wall extractor canopies series 110	page 110
Snack central extractor canopies	page 111
Wall extractor canopies - industrial series	page 112
Central extractor canopies - industrial series	page 113
Compensated wall extractor canopies - industrial series	page 114
Compensated central extractor canopies - industrial series	page 115
Inverted-filter wall extractor canopies	page 116
Inverted-filter wall extractor canopies and for ovens	page 117
Compensated inverted-filter wall extractor canopies	page 118
Compensated inverted-filter oven wall extractor canopies	page 119
Straight central extractor canopies- 110 deep	page 120
Re-circulating straight central extractor canopies- 110 deep	page 121
Straight steam wall extractor canopy	page 121
Straight central extractor canopies- 1800 deep	page 122
Straight central extractor canopies- 2200 deep	page 123
Compensated straight central extractor canopies- 1800 deep	page 124
Compensated central oven extractor canopies- 2200 deep	page 125
Automatic fire-extinction system	page 126
Turbines 400°/2h	page 126
Lighting	page 127
Wall extractor canopy shelf	page 127

The **Snack Series** is a practical, compact and solid range of extractor canopies designed to be integrated to small and medium sized kitchens. It offers a perfect balance between quality, functionality and price.



The **Industrial and Inverted-filter** extractor canopies are high performance, big, robust models designed to be installed in kitchens needing a large smoke extraction capacity.



Maximum quality
Utterly welded, solid, robust extractor canopies. They are manufactured of high quality AISI-304 18/10 stainless steel with superficial satin finish.



Perfect finishes
Utterly welded cover. Joints without rivets or seen screws. Flattened edges to facilitate its cleaning and avoid cutting injuries. Dividers-free equipment for a major extraction capacity.

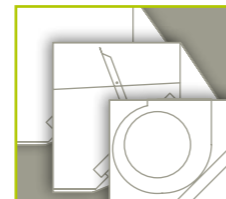

Functional plenum
Wide interior plenum which can optionally be equipped with individual regulation sliding flaps for each filter or different high quality extraction turbines.



Practical details and options
Optional fire-extinction system can be integrated. Included stainless steel slats filter. Solid wall anchors of easy and quick installation. Stainless steel drainage plugs. Cutting-proof flattened edges. Optional extraction cover is available

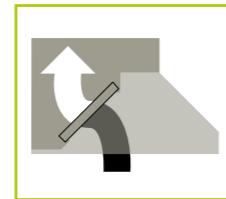

High performance
Outstanding extraction capacity thanks to its streamlined profile geometry, big size of its hood and plenum. Optionally, flow regulators can be integrated



Tight body
The surrounding hood is airtight sealed, avoiding smoke escapes and grease leaks. The drainage system conducts grease by means of gravity to the drainage plugs for disposal.

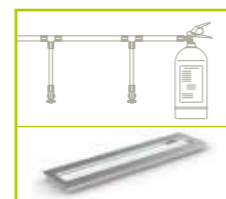

Options
The industrial and inverted-filter extractor canopies can be optionally equipped with fire self-extinguishing system. Airtight illumination of high brightness and low consumption and many other accessories are available.



Jointing kit
Equipment longer than 3 metres are supplied in two pieces with an easy-to-assemble sturdy jointing kit leaving a uniform unit perfectly finished.

SNACK LOW WALL EXTRACTOR CANOPIES

- Manufactured of satin finish AISI-304 18/10 stainless steel.
- Welded extractor canopy with flattened edges for an easy and safe cleaning.
- Exterior roof and backrest manufactured of galvanized steel.
- Oil drainage with threaded plug.
- Solid wall anchor easy to install (it includes screws and accessories).
- Optionally, it can integrate turbine of 400°C/2h as well as fire self-extinguishing system, see page 126.
- For extractor canopies longer than 3 metres, consult our staff.
- It includes AISI 430 stainless steel slats filters, 490x490x50mm.

LOW WALL EXTRACTOR CANOPY

Model	Dimensions	RRP (€)
CMB95-100	1000x950x500	849
CMB95-150	1500x950x500	1032
CMB95-200	2000x950x500	1222
CMB95-250	2500x950x500	1410
CMB95-300	3000x950x500	1798

LOW WALL EXTRACTOR CANOPY WITH TURBINE

Model	Turbine	Dimensions	RRP (€)
CMB95-100 1/5	9/9 1/5 cv	1000x950x500	1211
CMB95-100 1/2	9/9 1/2 cv	1000x950x500	1229
CMB95-150 1/5	9/9 1/5 cv	1500x950x500	1394
CMB95-150 1/2	9/9 1/2 cv	1500x950x500	1412
N CMB95-200 1/2	9/9 1/2 cv	2000x950x500	1602
N CMB95-250 3/4	9/9 3/4 cv	2500x950x500	1797
N CMB95-300 3/4	9/9 3/4 cv	3000x950x500	2185

SNACK STRAIGHT WALL EXTRACTOR CANOPIES

- Manufactured of satin finish AISI-304 18/10 stainless steel.
- Welded extractor canopy with flattened edges for an easy and safe cleaning.
- Exterior roof and backrest manufactured of galvanized steel.
- Oil drainage with threaded plug.
- Solid wall anchor easy to install (it includes screws and accessories).
- Optionally, it can integrate turbine of 400°C/2h, see page 126.
- For extractor canopies longer than 3 metres, consult our staff.
- It includes AISI 430 stainless steel slats filters, 490x490x50mm.

STRAIGHT WALL EXTRACTOR CANOPY

Model	Dimensions	RRP (€)
CMR95-100	1000x950x500	942
CMR95-150	1500x950x500	1146
CMR95-200	2000x950x500	1356
CMR95-250	2500x950x500	1565
CMR95-300	3000x950x500	1995

STRAIGHT WALL EXTRACTOR CANOPY WITH TURBINE

Model	Turbine	Dimensions	RRP (€)
CMR95-100 1/5	9/9 1/5 cv	1000x950x500	1304
CMR95-100 1/2	9/9 1/2 cv	1000x950x500	1322
CMR95-150 1/5	9/9 1/5 cv	1500x950x500	1508
CMR95-150 1/2	9/9 1/2 cv	1500x950x500	1526
N CMR95-200 1/2	9/9 1/2 cv	2000x950x500	1736
N CMR95-250 3/4	9/9 3/4 cv	2500x950x500	1952
N CMR95-300 3/4	9/9 3/4 cv	3000x950x500	2382

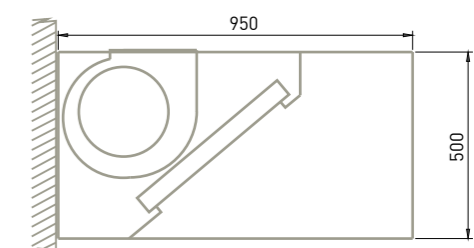
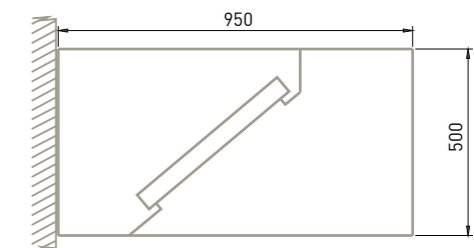
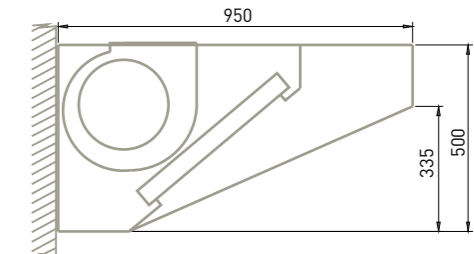
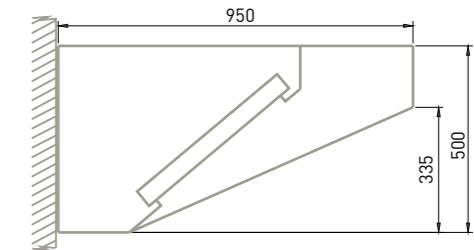
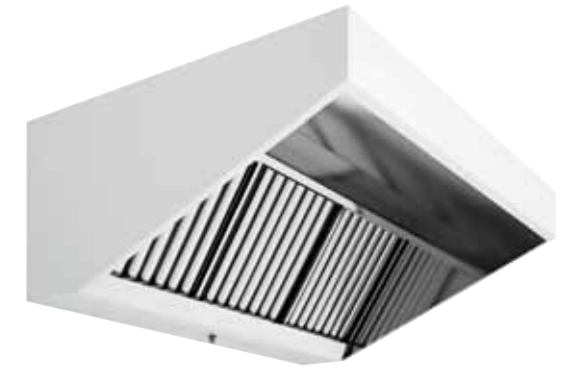

SNACK WALL EXTRACTOR CANOPIES SERIES 80



- Manufactured of satin finish AISI-304 18/10 stainless steel.
- Welded extractor canopy with flattened edges for an easy and safe cleaning.
- Exterior roof and backrest manufactured of galvanized steel.
- Oil drainage with threaded plug.
- Solid wall anchor easy to install (it includes screws and accessories).
- Models with regulation integrate an interior plenum with individual adjustable sliding flaps.
- Standard turbines can be replaced by other options, see page 126-127.
- Optionally, it can integrate turbine of 400°C/2h, see page 126.
- Optionally, fire self-extinguishing system can be integrated, see page 126.
- For extractor canopies longer than 3 metres, consult our staff.
- It includes AISI 430 stainless steel slats filters, 490x490x50mm.

WALL EXTRACTOR CANOPY SNACK 80

Model	Dimensions	RRP (€)
CMS80-100	1000x800x680	865
CMS80-125	1250x800x680	920
CMS80-150	1500x800x680	1060
CMS80-175	1750x800x680	1120
CMS80-200	2000x800x680	1260
CMS80-225	2250x800x680	1310
CMS80-250	2500x800x680	1443
CMS80-275	2750x800x680	1687
CMS80-300	3000x800x680	1826

WALL EXTRACTOR CANOPY SNACK 80 WITH REGULATION

Model	Dimensions	RRP (€)
CMS80-150P	1500x800x680	1220
CMS80-175P	1750x800x680	1293
CMS80-200P	2000x800x680	1439
CMS80-225P	2250x800x680	1520
CMS80-250P	2500x800x680	1695
CMS80-275P	2750x800x680	1986
CMS80-300P	3000x800x680	2147

WALL EXTRACTOR CANOPY SNACK 80 WITH TURBINE

Model	Turbine	Dimensions	RRP (€)
CMS80-100 1/5	9/9 1/5 cv	1000x800x680	1227
CMS80-100 1/2	9/9 1/2 cv	1000x800x680	1245
CMS80-125 1/5	9/9 1/5 cv	1250x800x680	1282
CMS80-125 1/2	9/9 1/2 cv	1250x800x680	1300
CMS80-150 1/5	9/9 1/5 cv	1500x800x680	1422
CMS80-150 1/2	9/9 1/2 cv	1500x800x680	1440
CMS80-175 1/2	9/9 1/2 cv	1750x800x680	1500
CMS80-200 1/2	9/9 1/2 cv	2000x800x680	1640
CMS80-225 1/2	9/9 1/2 cv	2250x800x680	1690
CMS80-250 3/4	9/9 3/4 cv	2500x800x680	1830
CMS80-250 1/3	10/10 1/3 cv	2500x800x680	1833
CMS80-275 3/4	9/9 3/4 cv	2750x800x680	2074
CMS80-275 1/3	10/10 1/3 cv	2750x800x680	2077
CMS80-300 3/4	10/10 3/4 cv	3000x800x680	2223

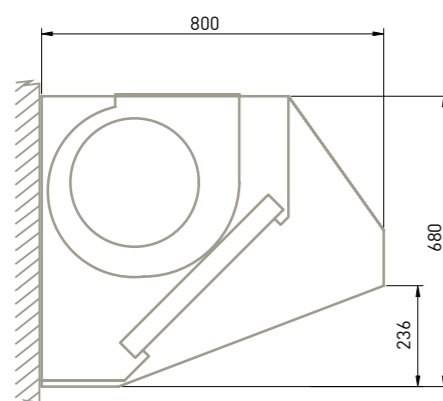
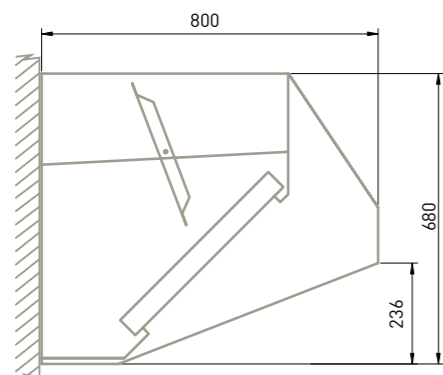
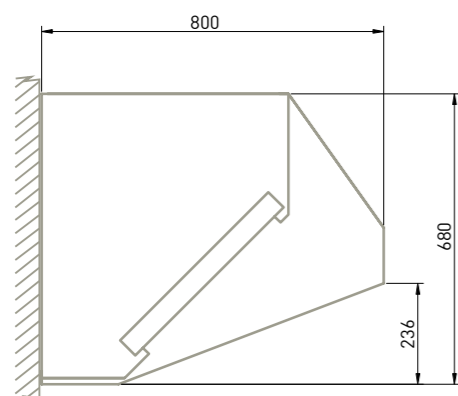

SNACK WALL EXTRACTOR CANOPIES SERIES 95



- Manufactured of satin finish AISI-304 18/10 stainless steel.
- Welded extractor canopy with flattened edges for an easy and safe cleaning.
- Exterior roof and backrest manufactured of galvanized steel.
- Oil drainage with threaded plug.
- Solid wall anchor easy to install (it includes screws and accessories).
- Models with regulation integrate an interior plenum with individual adjustable sliding flaps.
- In models with turbines, the standard turbine must be installed, for other options see page 126-127.
- Optionally, it can integrate turbine of 400°C/2h, see page 126.
- Optionally, fire self-extinguishing system can be integrated, see page 126.
- For extractor canopies longer than 3 metres, consult our staff.
- It includes AISI 430 stainless steel slats filters, 490x490x50mm.

WALL EXTRACTOR CANOPY SNACK 95

Model	Dimensions	RRP (€)
CMS95-100	1000x950x680	947
CMS95-125	1250x950x680	1002
CMS95-150	1500x950x680	1142
CMS95-175	1750x950x680	1201
CMS95-200	2000x950x680	1342
CMS95-225	2250x950x680	1392
CMS95-250	2500x950x680	1525
CMS95-275	2750x950x680	1798
CMS95-300	3000x950x680	1937

WALL EXTRACTOR CANOPY SNACK 95 WITH REGULATION

Model	Dimensions	RRP (€)
CMS95-150P	1500x950x680	1307
CMS95-175P	1750x950x680	1379
CMS95-200P	2000x950x680	1527
CMS95-225P	2250x950x680	1607
CMS95-250P	2500x950x680	1782
CMS95-275P	2750x950x680	2106
CMS95-300P	3000x950x680	2265

WALL EXTRACTOR CANOPY SNACK 95 WITH TURBINE

Model	Turbine	Dimensions	RRP (€)
CMS95-100 1/5	9/9 1/5 cv	1000x950x680	1309
CMS95-100 1/2	9/9 1/2 cv	1000x950x680	1327
CMS95-125 1/5	9/9 1/5 cv	1250x950x680	1364
CMS95-125 1/2	9/9 1/2 cv	1250x950x680	1382
CMS95-150 1/5	9/9 1/5 cv	1500x950x680	1504
CMS95-150 1/2	9/9 1/2 cv	1500x950x680	1522
CMS95-175 1/2	9/9 1/2 cv	1750x950x680	1581
CMS95-200 1/2	9/9 1/2 cv	2000x950x680	1722
CMS95-225 1/2	9/9 1/2 cv	2250x950x680	1772
CMS95-250 3/4	9/9 3/4 cv	2500x950x680	1912
CMS95-250 1/3	10/10 1/3 cv	2500x950x680	1915
CMS95-275 3/4	9/9 3/4 cv	2750x950x680	2185
CMS95-275 1/3	10/10 1/3 cv	2750x950x680	2188
CMS95-300 3/4	10/10 3/4 cv	3000x950x680	2334

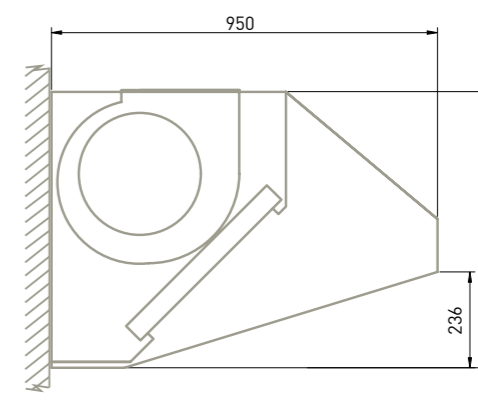
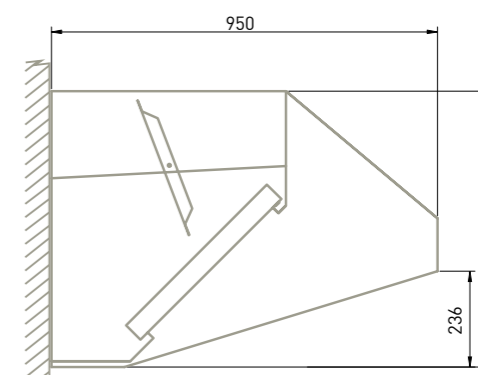
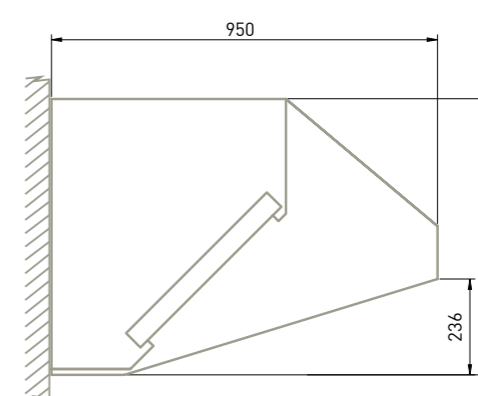

SNACK WALL EXTRACTOR CANOPIES SERIES 110



- Manufactured of satin finish AISI-304 18/10 stainless steel.
- Welded extractor canopy with flattened edges for an easy and safe cleaning.
- Exterior roof and backrest manufactured of galvanized steel.
- Oil drainage with threaded plug.
- Solid wall anchor easy to install (it includes screws and accessories).
- Models with adjustable integrate an interior plenum with individual adjustable sliding flaps.
- In models with turbines, the standard turbine must be installed, for other options see page 126-127.
- Optionally, it can integrate turbine of 400°C/2h, see page 126 as well as fire self-extinguishing system, see page 126.
- For extractor canopies longer than 3 metres, consult our staff.
- It includes AISI 430 stainless steel slats filters, 490x490x50mm.
- Optional lighting, see page 127.

WALL EXTRACTOR CANOPY SNACK 110

Model	Dimensions	RRP (€)
CMS110-100	1000x1100x680	994
CMS110-125	1250x1100x680	1.045
CMS110-150	1500x1100x680	1.196
CMS110-175	1750x1100x680	1.263
CMS110-200	2000x1100x680	1.412
CMS110-225	2250x1100x680	1.471
CMS110-250	2500x1100x680	1.610
CMS110-275	2750x1100x680	1.867
CMS110-300	3000x1100x680	2.015

WALL EXTRACTOR CANOPY SNACK 110 WITH REGULATION

Model	Dimensions	RRP (€)
CMS110-150P	1500x1100x680	1.365
CMS110-175P	1750x1100x680	1.445
CMS110-200P	2000x1100x680	1.601
CMS110-225P	2250x1100x680	1.691
CMS110-250P	2500x1100x680	1.875
CMS110-275P	2750x1100x680	2.179
CMS110-300P	3000x1100x680	2.350

WALL EXTRACTOR CANOPY SNACK 110 WITH TURBINE

Model	Turbine	Dimensions	RRP (€)
CMS110-100 1/5	9/9 1/5 cv	1000x1100x680	1356
CMS110-100 1/2	9/9 1/2 cv	1000x1100x680	1374
CMS110-125 1/5	9/9 1/5 cv	1250x1100x680	1407
CMS110-125 1/2	9/9 1/2 cv	1250x1100x680	1425
CMS110-150 1/5	9/9 1/5 cv	1500x1100x680	1558
CMS110-150 1/2	9/9 1/2 cv	1500x1100x680	1576
CMS110-175 1/2	9/9 1/2 cv	1750x1100x680	1643
CMS110-200 1/2	9/9 1/2 cv	2000x1100x680	1792
CMS110-225 1/2	9/9 1/2 cv	2250x1100x680	1851
CMS110-250 3/4	9/9 3/4 cv	2500x1100x680	1997
CMS110-250 1/3	10/10 1/3 cv	2500x1100x680	2000
CMS110-275 3/4	9/9 3/4 cv	2750x1100x680	2254
CMS110-275 1/3	10/10 1/3 cv	2750x1100x680	2257
CMS110-300 3/4	10/10 3/4 cv	3000x1100x680	2412

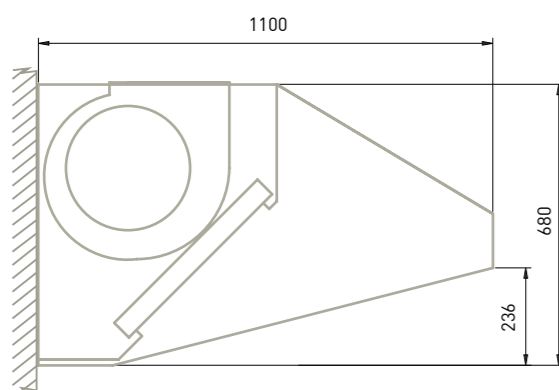
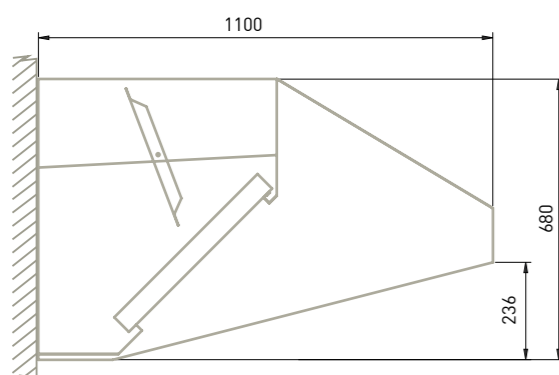
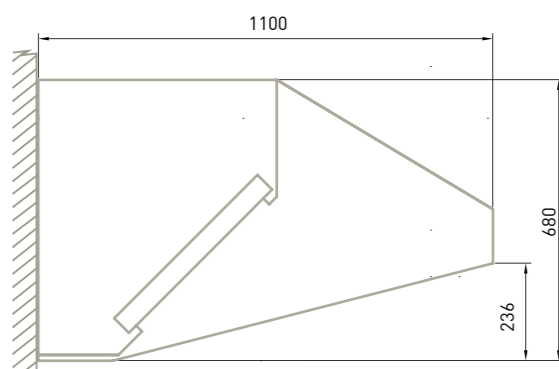

SNACK CENTRAL EXTRACTOR CANOPIES



- Manufactured of satin finish AISI-304 18/10 stainless steel.
- Welded extractor canopy with flattened edges for an easy and safe cleaning.
- Exterior roof manufactured of galvanized steel.
- Oil drainage with threaded plug.
- Solid ceiling anchor easy to install.
- In models with turbines, the standard installed turbine is indicated, for other options see page 126-127.
- Optionally, it can integrate turbine of 400°C/2h, see page 126 as well as fire self-extinguishing system, see page 126.
- For extractor canopies longer than 3 metres, consult our staff.
- It includes AISI 430 stainless steel slats filters, 490x490x50mm.
- Optional lighting, see page 127.

SNACK CENTRAL EXTRACTOR CANOPY

Model	Dimensions	RRP (€)
CCS-150	1500x1675x680	1.823
CCS-175	1750x1675x680	1.902
CCS-200	2000x1675x680	2.151
CCS-225	2250x1675x680	2.229
CCS-250	2500x1675x680	2.487
CCS-275	2750x1675x680	2.877
CCS-300	3000x1675x680	3.121

SNACK CENTRAL EXTRACTOR CANOPY WITH TURBINE

Model	Turbine	Dimensions	RRP (€)
CCS-150 1cv	12/9 1 cv	1500x1675x680	2.384
CCS-175 1cv	12/9 1 cv	1750x1675x680	2.463
CCS-200 1cv	12/9 1 cv	1500x1675x680	2.712
CCS-225 1,5cv	12/12 1,5 cv	2250x1675x680	2.842
CCS-250 1,5cv	12/12 1,5 cv	2500x1675x680	3.100
CCS-275 1,5cv	12/12 1,5 cv	2750x1675x680	3.490
CCS-300 1,5cv	12/12 1,5 cv	3000x1675x680	3.734

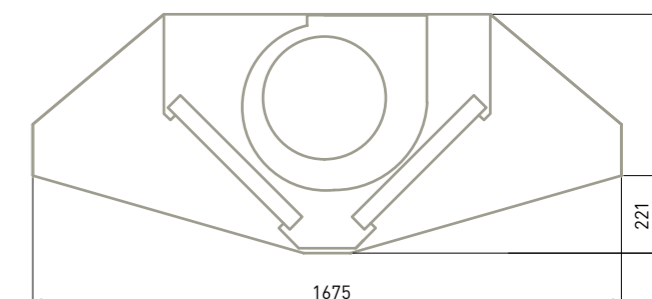
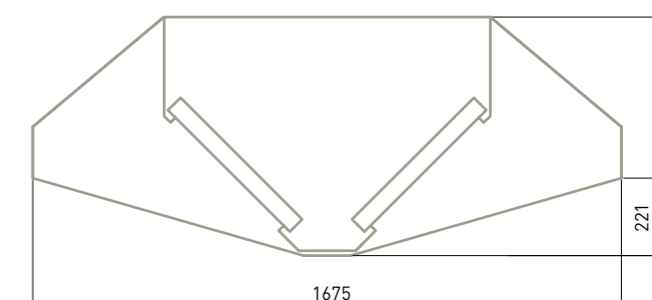

WALL EXTRACTOR CANOPIES - INDUSTRIAL SERIES



- Manufactured of satin finish AISI-304 18/10 stainless steel.
- Maximum extraction capacity thanks to its streamlined profile geometry, big size of its hood and exterior plenum.
- Welded extractor canopy with flattened edges for an easy and safe cleaning.
- Exterior roof and backrest manufactured of galvanized steel.
- Oil drainage with threaded plug.
- Solid wall anchor easy to install (screws and accessories included).
- Models with regulation integrate an interior plenum with individual adjustable sliding flaps.
- Extractor canopies longer than 3 metres are supplied in two pieces with a sturdy easy to assemble unseen jointing kit.
- Optional lighting, see page 127.
- Optional fire self-extinguishing system, see page 126.
- It includes AISI 430 stainless steel slats filters, 490x490x50mm.

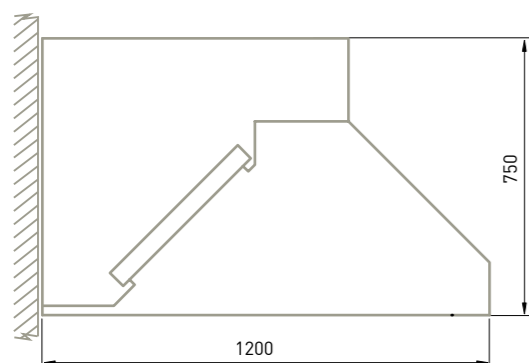

WALL INDUSTRIAL EXTRACTOR CANOPY

Model	Dimensions	RRP (€)
CMI-150	1500x1200x750	1.474
CMI-200	2000x1200x750	1.803
CMI-250	2500x1200x750	2.067
CMI-300	3000x1200x750	2.559
CMI-350	3500x1200x750	2.889
CMI-400	4000x1200x750	3.218
CMI-450	4500x1200x750	3.478
CMI-500	5000x1200x750	3.742
CMI-550	5500x1200x750	4.302
CMI-600	6000x1200x750	4.628

WALL INDUSTRIAL EXTRACTOR CANOPY WITH REGULATING PLENUM

Model	Dimensions	RRP (€)
CMI-150P	1500x1200x750	1.650
CMI-200P	2000x1200x750	2.019
CMI-250P	2500x1200x750	2.314
CMI-300P	3000x1200x750	2.865
CMI-350P	3500x1200x750	3.235
CMI-400P	4000x1200x750	3.603
CMI-450P	4500x1200x750	3.896
CMI-500P	5000x1200x750	4.191
CMI-550P	5500x1200x750	4.817
CMI-600P	6000x1200x750	5.184

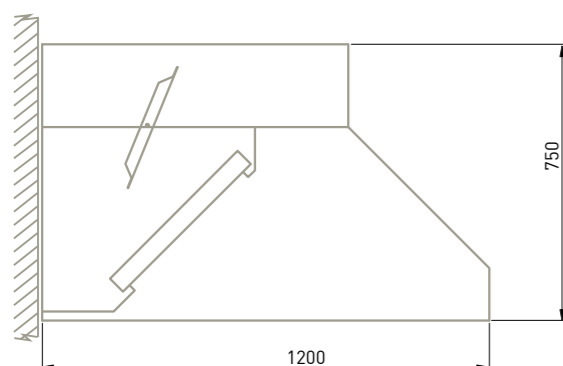

CENTRAL EXTRACTOR CANOPIES - INDUSTRIAL SERIES



- Manufactured of satin finish AISI-304 18/10 stainless steel.
- Maximum extraction capacity thanks to its streamlined profile geometry, big size of its hood and exterior plenum.
- Welded extractor canopy with flattened edges for an easy and safe cleaning.
- Exterior roof manufactured of galvanized steel.
- Oil drainage with threaded plug.
- Solid ceiling anchor easy to install
- Models with regulation integrate an interior plenum with individual adjustable sliding flaps.
- Extractor canopies longer than 3 metres are supplied in two pieces with a sturdy easy to assemble unseen jointing kit.
- Optional lighting, see page 127.
- Optional fire self-extinguishing system, see page 126.
- It includes AISI 430 stainless steel slats filters, 490x490x50mm.

CENTRAL INDUSTRIAL EXTRACTOR CANOPY

Model	Dimensions	RRP (€)
CCI-200	2000x2200x750	3.260
CCI-250	2500x2200x750	3.693
CCI-300	3000x2200x750	4.538
CCI-350	3500x2200x750	4.764
CCI-400	4000x2200x750	5.800
CCI-450	4500x2200x750	6.232
CCI-500	5000x2200x750	6.666
CCI-550	5500x2200x750	7.528
CCI-600	6000x2200x750	8.144

CENTRAL INDUSTRIAL EXTRACTOR CANOPY WITH REGULATING PLENUM

Model	Dimensions	RRP (€)
CCI-200P	2000x2200x750	3.651
CCI-250P	2500x2200x750	4.136
CCI-300P	3000x2200x750	5.083
CCI-350P	3500x2200x750	5.783
CCI-400P	4000x2200x750	6.496
CCI-450P	4500x2200x750	6.980
CCI-500P	5000x2200x750	7.465
CCI-550P	5500x2200x750	8.432
CCI-600P	6000x2200x750	9.122

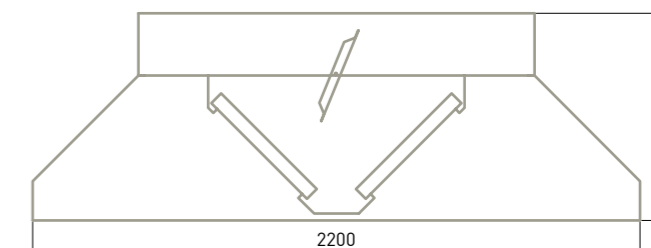
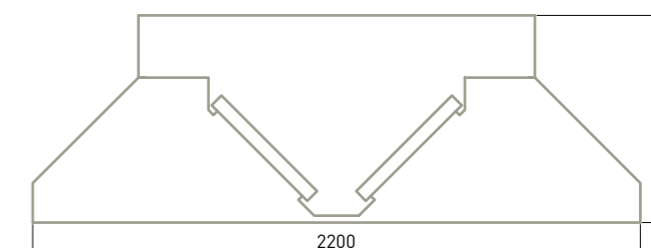

COMPENSATED WALL EXTRACTOR CANOPIES - INDUSTRIAL SERIES



- Manufactured of satin finish AISI-304 18/10 stainless steel.
- Maximum extraction capacity thanks to its streamlined profile geometry, big size of its hood and exterior plenum.
- Air output plenum with integrated grille.
- Welded extractor canopy with flattened edges for an easy and safe cleaning.
- Exterior roof and backrest manufactured of galvanized steel.
- Oil drainage with threaded plug.
- Solid wall anchor easy to install (screws and accessories included).
- Models with regulation integrate an interior plenum with individual adjustable sliding flaps.
- Extractor canopies longer than 3 metres are supplied in two pieces with a sturdy easy to assemble unseen jointing kit.
- Optional lighting, see page 127.
- Optional fire self-extinguishing system, see page 126.
- It includes AISI 430 stainless steel slats filters, 490x490x50mm.

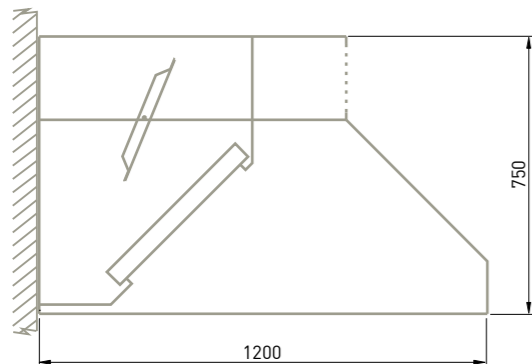
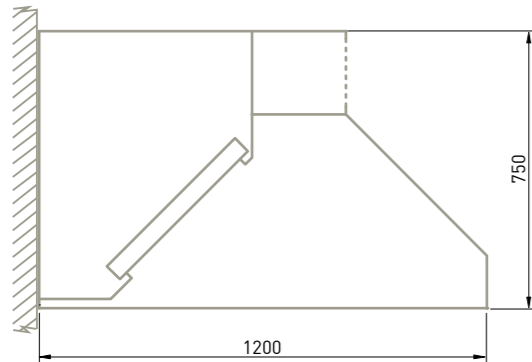

COMPENSATED WALL INDUSTRIAL EXTRACTOR CANOPY

Model	Dimensions	RRP (€)
CMIC-150	1500x1200x750	1.712
CMIC-200	2000x1200x750	2.094
CMIC-250	2500x1200x750	2.399
CMIC-300	3000x1200x750	2.972
CMIC-350	3500x1200x750	3.355
CMIC-400	4000x1200x750	3.736
CMIC-450	4500x1200x750	4.041
CMIC-500	5000x1200x750	4.346
CMIC-550	5500x1200x750	4.995
CMIC-600	6000x1200x750	5.376

COMPENSATED WALL INDUSTRIAL EXTRACTOR CANOPY WITH REGULATING PLENUM

Model	Dimensions	RRP (€)
CMIC-150P	1500x1200x750	1.849
CMIC-200P	2000x1200x750	2.261
CMIC-250P	2500x1200x750	2.591
CMIC-300P	3000x1200x750	3.209
CMIC-350P	3500x1200x750	3.623
CMIC-400P	4000x1200x750	4.035
CMIC-450P	4500x1200x750	4.365
CMIC-500P	5000x1200x750	4.694
CMIC-550P	5500x1200x750	5.395
CMIC-600P	6000x1200x750	5.807

COMPENSATED CENTRAL EXTRACTOR CANOPIES - INDUSTRIAL SERIES



- Manufactured of satin finish AISI-304 18/10 stainless steel.
- Maximum extraction capacity thanks to its streamlined profile geometry, big size of its hood and exterior plenum.
- Air output plenum with integrated grille.
- Welded extractor canopy with flattened edges for an easy and safe cleaning.
- Exterior roof manufactured of galvanized steel.
- Oil drainage with threaded plug.
- Solid ceiling anchor easy to install
- Models with regulation integrate an interior plenum with individual adjustable sliding flaps.
- Extractor canopies longer than 3 metres are supplied in two pieces with a sturdy easy to assemble unseen jointing kit.
- Optional lighting, see page 127.
- Optional fire self-extinguishing system, see page 126.
- It includes AISI 430 stainless steel slats filters, 490x490x50mm.

COMPENSATED CENTRAL INDUSTRIAL EXTRACTOR CANOPY

Model	Dimensions	RRP (€)
CCIC-200	2000x2200x750	3.731
CCIC-250	2500x2200x750	4.226
CCIC-300	3000x2200x750	5.193
CCIC-350	3500x2200x750	6.042
CCIC-400	4000x2200x750	6.637
CCIC-450	4500x2200x750	7.132
CCIC-500	5000x2200x750	7.627
CCIC-550	5500x2200x750	8.615
CCIC-600	6000x2200x750	9.320

COMPENSATED CENTRAL INDUSTRIAL EXTRACTOR CANOPY WITH REGULATING PLENUM

Model	Dimensions	RRP (€)
CCIC-200P	2000x2200x750	4.128
CCIC-250P	2500x2200x750	4.675
CCIC-300P	3000x2200x750	5.745
CCIC-350P	3500x2200x750	6.743
CCIC-400P	4000x2200x750	7.343
CCIC-450P	4500x2200x750	7.891
CCIC-500P	5000x2200x750	8.438
CCIC-550P	5500x2200x750	9.531
CCIC-600P	6000x2200x750	10.311

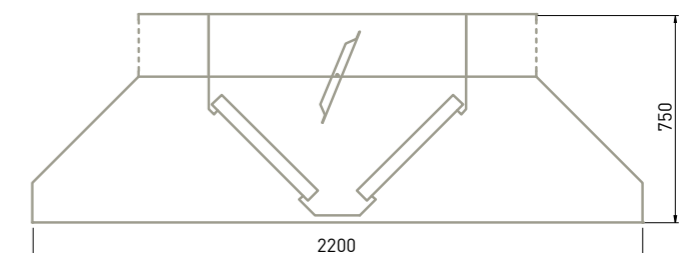
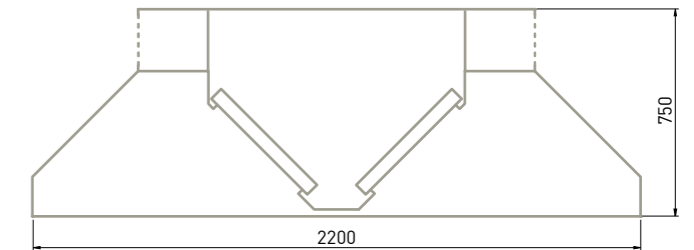

INVERTED-FILTER WALL EXTRACTOR CANOPIES



- Manufactured of satin finish AISI-304 18/10 stainless steel.
- Welded extractor canopy with flattened edges for an easy and safe cleaning.
- Exterior roof manufactured of galvanized steel.
- Oil drainage with threaded plug.
- Solid wall anchor easy to install (screws and accessories included).
- Models with regulation integrate an interior plenum with individual regulation sliding flaps.
- Extractor canopies longer than 3 metres are supplied in two pieces with a sturdy easy to assemble unseen jointing kit.
- Optional fire self-extinguishing system, see page 126.
- It includes AISI 430 stainless steel slats filters, 490x490x50mm.
- Optional lighting, see page 127.

INVERTED-FILTER WALL EXTRACTOR CANOPY

Model	Dimensions	RRP (€)
CMH11-100	1000x1150x500	1.157
CMH11-150	1500x1150x500	1.434
CMH11-200	2000x1150x500	1.713
CMH11-250	2500x1150x500	2.005
CMH11-300	3000x1150x500	2.500
CMH11-350	3500x1150x500	2.779
CMH11-400	4000x1150x500	3.058
CMH11-450	4500x1150x500	3.350
CMH11-500	5000x1150x500	3.539
CMH11-550	5500x1150x500	4.009
CMH11-600	6000x1150x500	4.280

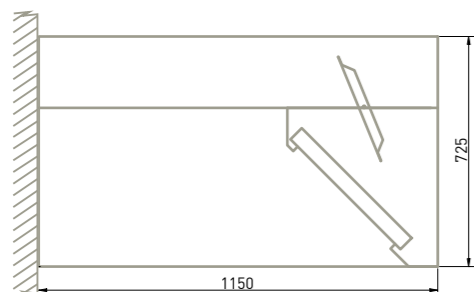
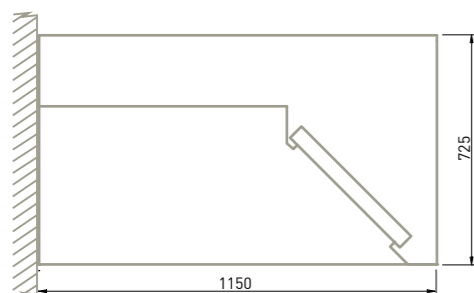
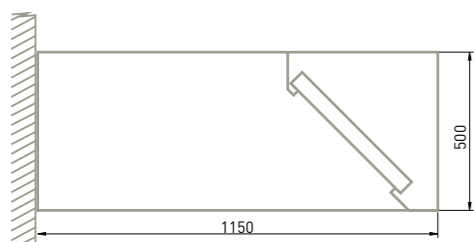

INVERTED-FILTER WALL EXTRACTOR CANOPY WITH PLENUM

Model	Dimensions	RRP (€)
CMH11-150H	1500x1150x725	1.570
CMH11-200H	2000x1150x725	1.876
CMH11-250H	2500x1150x725	2.195
CMH11-300H	3000x1150x725	2.737
CMH11-350H	3500x1150x725	3.043
CMH11-400H	4000x1150x725	3.348
CMH11-450H	4500x1150x725	3.668
CMH11-500H	5000x1150x725	3.875
CMH11-550H	5500x1150x725	4.390
CMH11-600H	6000x1150x725	4.687

INVERTED-FILTER WALL EXTRACTOR CANOPY WITH REGULATING PLENUM

Model	Dimensions	RRP (€)
CMH11-150P	1500x1150x725	1.743
CMH11-200P	2000x1150x725	2.082
CMH11-250P	2500x1150x725	2.437
CMH11-300P	3000x1150x725	3.039
CMH11-350P	3500x1150x725	3.378
CMH11-400P	4000x1150x725	3.717
CMH11-450P	4500x1150x725	4.072
CMH11-500P	5000x1150x725	4.302
CMH11-550P	5500x1150x725	4.873
CMH11-600P	6000x1150x725	5.203

INVERTED-FILTER WALL EXTRACTOR CANOPIES FOR OVENS



- Manufactured of satin finish AISI-304 18/10 stainless steel.
- Welded extractor canopy with flattened edges for an easy and safe cleaning.
- Exterior roof manufactured of galvanized steel.
- Oil drainage with threaded plug.
- Solid wall anchor easy to install (screws and accessories included).
- Models with regulation integrate an interior plenum with individual regulation sliding flaps.
- Extractor canopies longer than 3 metres are supplied in two pieces with a sturdy easy to assemble unseen jointing kit.
- Optional fire self-extinguishing system, see page 126.
- It includes AISI 430 stainless steel slats filters, 490x490x50mm.
- Optional lighting, see page 127.

WALL EXTRACTOR CANOPY FOR OVENS

Model	Dimensions	RRP (€)
CMH15-100	1000x1500x500	1.259
CMH15-150	1500x1500x500	1.547
CMH15-200	2000x1500x500	1.826
CMH15-250	2500x1500x500	2.117
CMH15-300	3000x1500x500	2.658
CMH15-350	3500x1500x500	2.937
CMH15-400	4000x1500x500	3.217
CMH15-450	4500x1500x500	3.508
CMH15-500	5000x1500x500	3.694
CMH15-550	5500x1500x500	4.207
CMH15-600	6000x1500x500	4.478

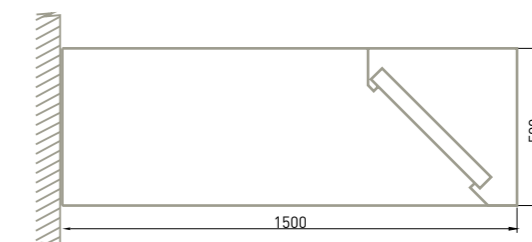

WALL EXTRACTOR CANOPY FOR OVENS WITH PLENUM

Model	Dimensions	RRP (€)
CMH15-150H	1500x1500x725	1.694
CMH15-200H	2000x1500x725	2.000
CMH15-250H	2500x1500x725	2.318
CMH15-300H	3000x1500x725	2.911
CMH15-350H	3500x1500x725	3.217
CMH15-400H	4000x1500x725	3.522
CMH15-450H	4500x1500x725	3.841
CMH15-500H	5000x1500x725	4.045
CMH15-550H	5500x1500x725	4.607
CMH15-600H	6000x1500x725	4.903

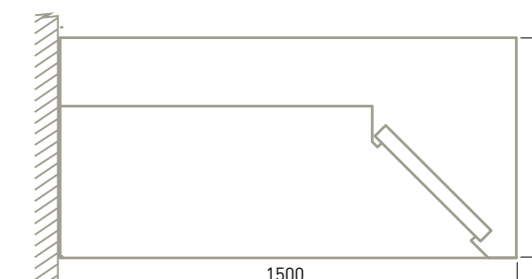

WALL EXTRACTOR CANOPY FOR OVENS WITH REGULATING PLENUM

Model	Dimensions	RRP (€)
CMH15-150P	1500x1500x725	1.881
CMH15-200P	2000x1500x725	2.220
CMH15-250P	2500x1500x725	2.573
CMH15-300P	3000x1500x725	3.231
CMH15-350P	3500x1500x725	3.571
CMH15-400P	4000x1500x725	3.910
CMH15-450P	4500x1500x725	4.263
CMH15-500P	5000x1500x725	4.489
CMH15-550P	5500x1500x725	5.114
CMH15-600P	6000x1500x725	5.442

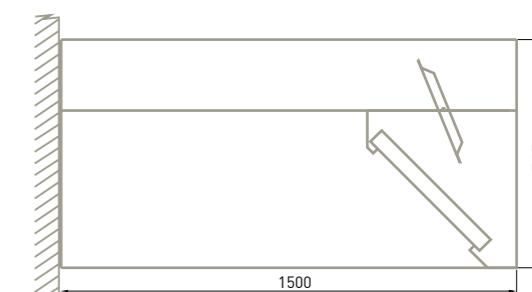

COMPENSATED INVERTED-FILTER WALL EXTRACTOR CANOPIES



- Manufactured of satin finish AISI-304 18/10 stainless steel.
- Lateral air output plenum with integrated grille.
- Welded extractor canopy with flattened edges for an easy and safe cleaning.
- Exterior roof manufactured of galvanized steel.
- Oil drainage with threaded plug.
- Solid wall anchor easy to install (screws and accessories included).
- Models with regulation integrate an interior plenum with individual adjustable sliding flaps.
- Extractor canopies longer than 3 metres are supplied in two pieces with a sturdy easy to assemble unseen jointing kit.
- Optional lighting, see page 127.
- Optional fire self-extinguishing system, see page 126.
- It includes AISI 430 stainless steel slats filters, 490x490x50mm.

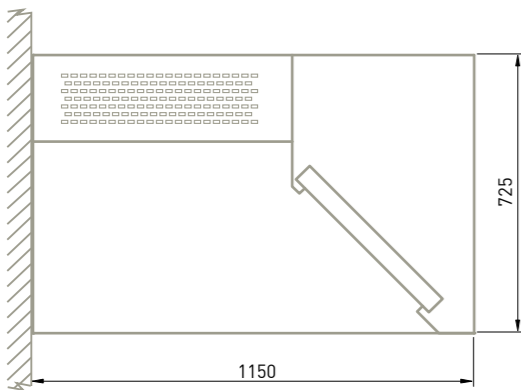

COMPENSATED INVERTED-FILTER WALL EXTRACTOR CANOPY

Model	Dimensions	RRP (€)
CMHC11-150H	1500x1150x725	1.757
CMHC11-200H	2000x1150x725	2.191
CMHC11-250H	2500x1150x725	2.518
CMHC11-300H	3000x1150x725	3.128
CMHC11-350H	3500x1150x725	3.564
CMHC11-400H	4000x1150x725	3.998
CMHC11-450H	4500x1150x725	4.324
CMHC11-500H	5000x1150x725	4.651
CMHC11-550H	5500x1150x725	5.219
CMHC11-600H	6000x1150x725	5.641

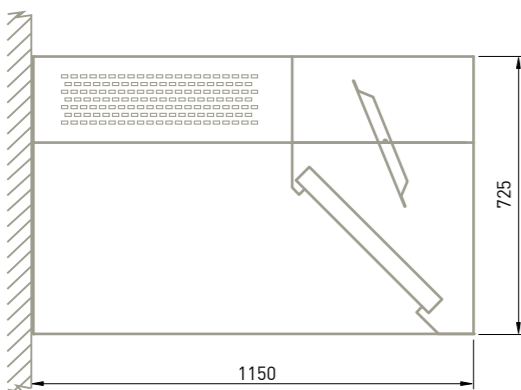

COMPENSATED INVERTED-FILTER WALL EXTRACTOR CANOPY WITH REGULATING PLENUM

Model	Dimensions	RRP (€)
CMHC11-150P	1500x1150x725	1.889
CMHC11-200P	2000x1150x725	2.356
CMHC11-250P	2500x1150x725	2.707
CMHC11-300P	3000x1150x725	3.363
CMHC11-350P	3500x1150x725	3.831
CMHC11-400P	4000x1150x725	4.298
CMHC11-450P	4500x1150x725	4.649
CMHC11-500P	5000x1150x725	5.000
CMHC11-550P	5500x1150x725	5.611
CMHC11-600P	6000x1150x725	6.065

COMPENSATED INVERTED-FILTER OVEN WALL EXTRACTOR CANOPIES



- Manufactured of satin finish AISI-304 18/10 stainless steel.
- Lateral air output plenum with integrated grille.
- Welded extractor canopy with flattened edges for an easy and safe cleaning.
- Exterior roof manufactured of galvanized steel.
- Oil drainage with threaded plug.
- Solid wall anchor easy to install (screws and accessories included).
- Models with regulation integrate an interior plenum with individual adjustable sliding flaps.
- Extractor canopies longer than 3 metres are supplied in two pieces with a sturdy easy to assemble unseen jointing kit.
- Optional embedded or on-surface lighting, see page 127.
- Optional fire self-extinguishing system, see page 126.
- It includes AISI 430 stainless steel slats filters, 490x490x50mm.

COMPENSATED INVERTED-FILTER OVEN WALL EXTRACTOR CANOPY

Model	Dimensions	RRP (€)
CMHC15-150H	1500x1500x725	1.875
CMHC15-200H	2000x1500x725	2.310
CMHC15-250H	2500x1500x725	2.636
CMHC15-300H	3000x1500x725	3.295
CMHC15-350H	3500x1500x725	3.729
CMHC15-400H	4000x1500x725	4.164
CMHC15-450H	4500x1500x725	4.490
CMHC15-500H	5000x1500x725	4.817
CMHC15-550H	5500x1500x725	5.427
CMHC15-600H	6000x1500x725	5.849

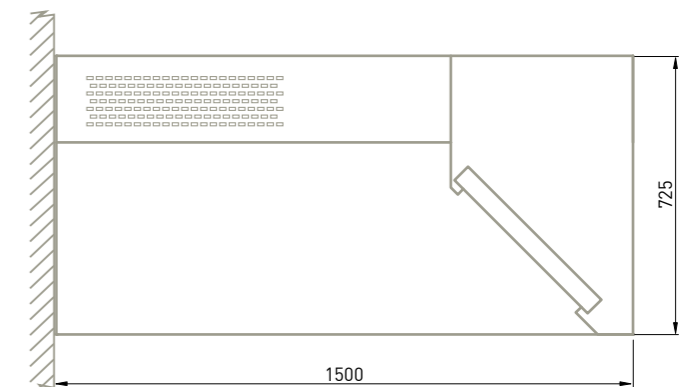

COMPENSATED INVERTED-FILTER OVEN WALL EXTRACTOR CANOPY WITH REGULATING PLENUM

Model	Dimensions	RRP (€)
CMHC15-150P	1500x1500x725	2.016
CMHC15-200P	2000x1500x725	2.484
CMHC15-250P	2500x1500x725	2.834
CMHC15-300P	3000x1500x725	3.541
CMHC15-350P	3500x1500x725	4.009
CMHC15-400P	4000x1500x725	4.476
CMHC15-450P	4500x1500x725	4.827
CMHC15-500P	5000x1500x725	5.179
CMHC15-550P	5500x1500x725	5.834
CMHC15-600P	6000x1500x725	6.288

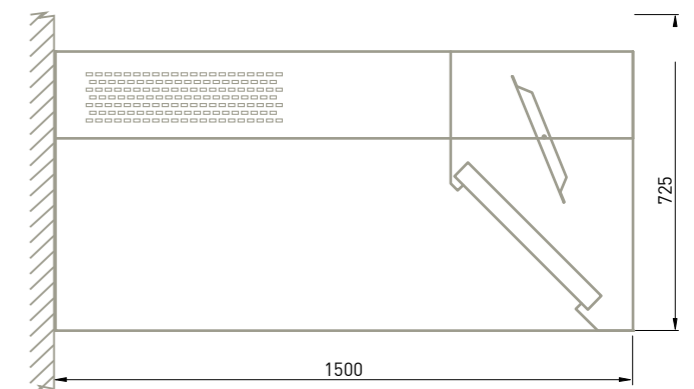

NEW

STRAIGHT CENTRAL EXTRACTOR CANOPIES- 110 DEEP



- Manufactured of satin finish AISI-304 18/10 stainless steel.
- Welded extractor canopy with flattened edges for an easy and safe cleaning.
- Exterior roof manufactured of galvanized steel.
- Solid anchor easy to install.
- Oil drainage with threaded plug.
- Models with adjustable integrate an interior plenum with individual adjustable sliding flaps.
- Extractor canopies longer than 3 metres are supplied in two pieces with a sturdy easy to assemble unseen jointing kit.
- Optional embedded or on-surface lighting, see page 127.
- It includes AISI 430 stainless steel slats filters, 490x490x50mm.

STRAIGHT CENTRAL EXTRACTOR CANOPY

Model	Dimensions	RRP (€)
CCR11-100	1000x1150x500	1.357
CCR11-150	1500x1150x500	1.634
CCR11-200	2000x1150x500	1.913
CCR11-250	2500x1150x500	2.205
CCR11-300	3000x1150x500	2.700
CCR11-350	3500x1150x500	3.177
CCR11-400	4000x1150x500	3.456
CCR11-450	4500x1150x500	3.747
CCR11-500	5000x1150x500	3.937
CCR11-550	5500x1150x500	4.407
CCR11-600	6000x1150x500	4.678

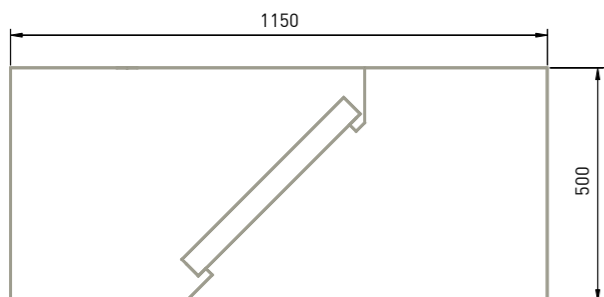

STRAIGHT CENTRAL EXTRACTOR CANOPY WITH PLENUM

Model	Dimensions	RRP (€)
CCR11-150H	1500x1150x725	1.770
CCR11-200H	2000x1150x725	2.076
CCR11-250H	2500x1150x725	2.395
CCR11-300H	3000x1150x725	2.937
CCR11-350H	3500x1150x725	3.441
CCR11-400H	4000x1150x725	3.746
CCR11-450H	4500x1150x725	4.066
CCR11-500H	5000x1150x725	4.273
CCR11-550H	5500x1150x725	4.788
CCR11-600H	6000x1150x725	5.085

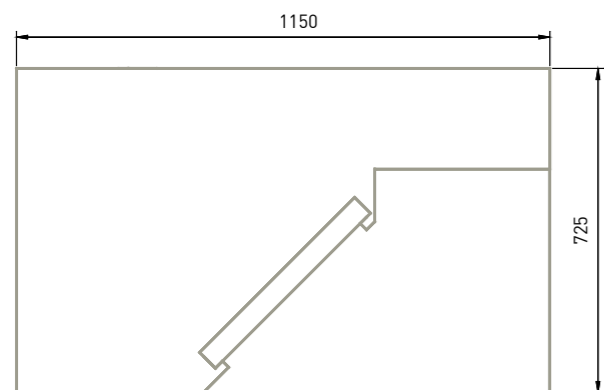

STRAIGHT CENTRAL EXTRACTOR CANOPY WITH REGULATING PLENUM

Model	Dimensions	RRP (€)
CCR11-150P	1500x1150x725	1.943
CCR11-200P	2000x1150x725	2.282
CCR11-250P	2500x1150x725	2.637
CCR11-300P	3000x1150x725	3.239
CCR11-350P	3500x1150x725	3.776
CCR11-400P	4000x1150x725	4.115
CCR11-450P	4500x1150x725	4.470
CCR11-500P	5000x1150x725	4.699
CCR11-550P	5500x1150x725	5.271
CCR11-600P	6000x1150x725	5.601

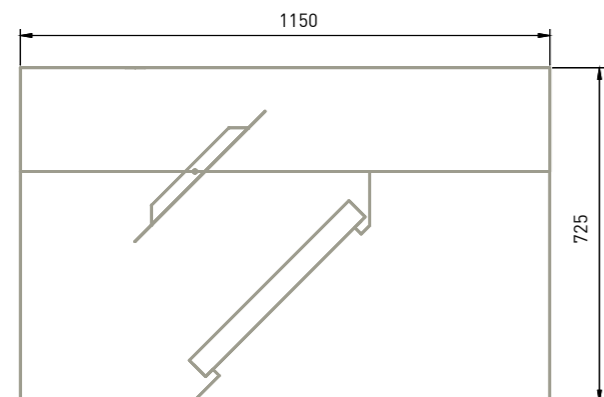

RE-CIRCULATING STRAIGHT CENTRAL EXTRACTOR CANOPIES- 110 DEEP

NEW

- Manufactured of satin finish AISI-304 18/10 stainless steel.
- Welded extractor canopy with flattened edges for an easy and safe cleaning.
- Air flow through lower edge.
- Exterior roof manufactured of galvanized steel.
- Oil drainage with threaded plug.
- Solid anchor easy to install.
- Extractor canopies longer than 3 metres are supplied in two pieces with a sturdy easy to assemble unseen jointing kit.
- Optional embedded or on-surface lighting, see page 127.
- It includes AISI 430 stainless steel slats filters, 490x490x50mm.
- Specially designed for show cooking.

RE-CIRCULATING STRAIGHT CENTRAL EXTRACTOR CANOPY

Model	Dimensions	RRP (€)
CCRI11-150	1500x1150x725	2.025
CCRI11-200	2000x1150x725	2.330
CCRI11-250	2500x1150x725	2.650
CCRI11-300	3000x1150x725	3.192

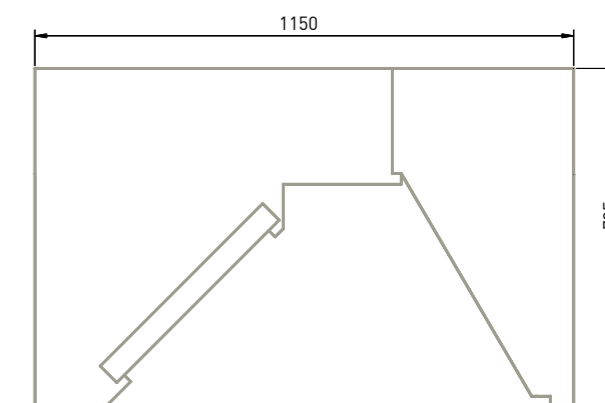

STRAIGHT STEAM WALL EXTRACTOR CANOPY

NEW

- Manufactured of satin finish AISI-304 18/10 stainless steel.
- Welded extractor canopy with flattened edges for an easy and safe cleaning.
- Oil drainage with threaded plug.
- Solid wall anchor easy to install (screws and accessories included).

STRAIGHT STEAM WALL EXTRACTOR CANOPY

Model	Dimensions	RRP (€)
CMV-100	1000x1000x500	798

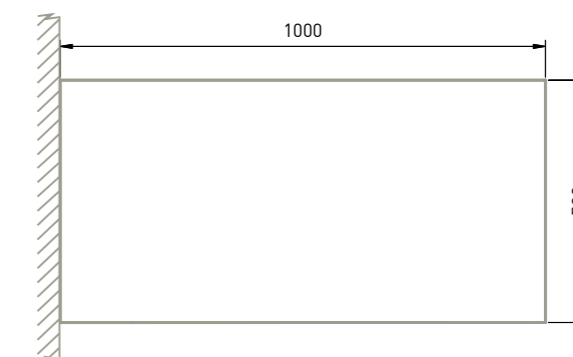

NEW

STRAIGHT CENTRAL EXTRACTOR CANOPIES- 1800 DEEP



- Manufactured of satin finish AISI-304 18/10 stainless steel.
- Welded extractor canopy with flattened edges for an easy and safe cleaning.
- Exterior roof manufactured of galvanized steel.
- Solid anchor easy to install.
- Oil drainage with threaded plug.
- Models with adjustable integrate an interior plenum with individual adjustable sliding flaps.
- Extractor canopies longer than 3 metres are supplied in two pieces with a sturdy easy to assemble unseen jointing kit.
- Optional lighting, see page 127.
- It includes AISI 430 stainless steel slats filters, 490x490x50mm.

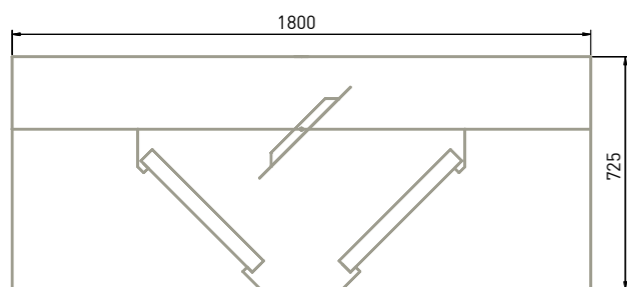
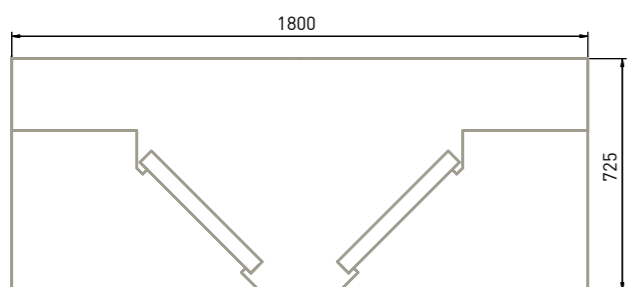
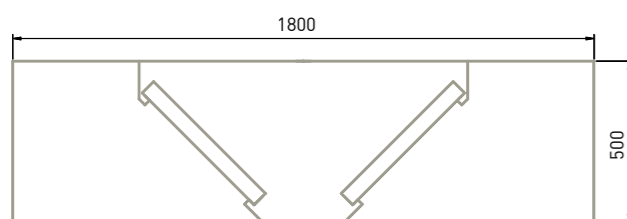

STRAIGHT CENTRAL EXTRACTOR CANOPY

Model	Dimensions	RRP (€)
CCR18-200	2000x1800x500	3.219
CCR18-250	2500x1800x500	3.630
CCR18-300	3000x1800x500	4.433
CCR18-350	3500x1800x500	4.648
CCR18-400	4000x1800x500	5.631
CCR18-450	4500x1800x500	6.042
CCR18-500	5000x1800x500	6.454
CCR18-550	5500x1800x500	7.273
CCR18-600	6000x1800x500	7.859

STRAIGHT CENTRAL EXTRACTOR CANOPY WITH PLENUM

Model	Dimensions	RRP (€)
CCR18-200H	2000x1800x725	3.427
CCR18-250H	2500x1800x725	3.871
CCR18-300H	3000x1800x725	4.736
CCR18-350H	3500x1800x725	4.983
CCR18-400H	4000x1800x725	5.998
CCR18-450H	4500x1800x725	6.442
CCR18-500H	5000x1800x725	6.876
CCR18-550H	5500x1800x725	7.754
CCR18-600H	6000x1800x725	8.370

STRAIGHT CENTRAL EXTRACTOR CANOPY WITH REGULATING PLENUM

Model	Dimensions	RRP (€)
CCR18-200P	2000x1800x725	3.817
CCR18-250P	2500x1800x725	4.315
CCR18-300P	3000x1800x725	5.281
CCR18-350P	3500x1800x725	5.597
CCR18-400P	4000x1800x725	6.694
CCR18-450P	4500x1800x725	7.190
CCR18-500P	5000x1800x725	7.675
CCR18-550P	5500x1800x725	8.657
CCR18-600P	6000x1800x725	9.347

STRAIGHT CENTRAL EXTRACTOR CANOPIES- 2200 DEEP

NEW



- Manufactured of satin finish AISI-304 18/10 stainless steel.
- Welded extractor canopy with flattened edges for an easy and safe cleaning.
- Exterior roof manufactured of galvanized steel.
- Solid anchor easy to install.
- Oil drainage with threaded plug.
- Models with adjustable integrate an interior plenum with individual adjustable sliding flaps.
- Extractor canopies longer than 3 metres are supplied in two pieces with a sturdy easy to assemble unseen jointing kit.
- Optional lighting, see page 127.
- It includes AISI 430 stainless steel slats filters, 490x490x50mm.

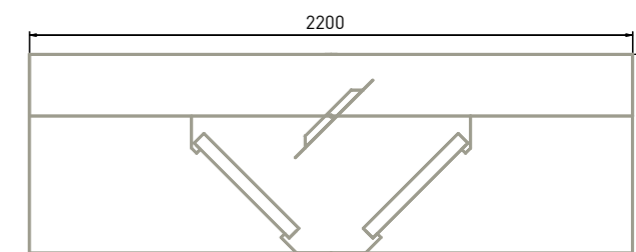
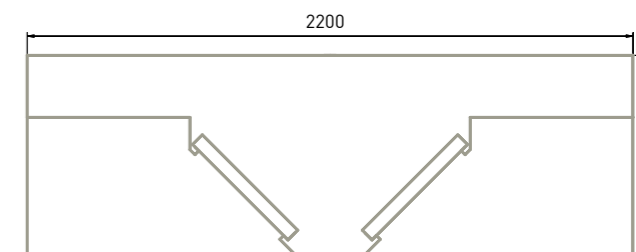
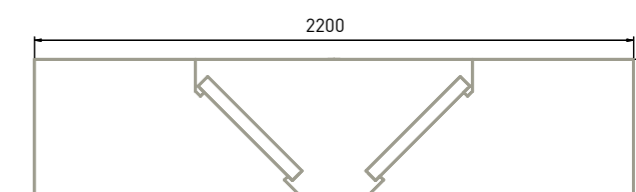

STRAIGHT CENTRAL EXTRACTOR CANOPY

Model	Dimensions	RRP (€)
CCR22-200	2000x1800x500	3.545
CCR22-250	2500x1800x500	3.999
CCR22-300	3000x1800x500	4.887
CCR22-350	3500x1800x500	5.125
CCR22-400	4000x1800x500	6.212
CCR22-450	4500x1800x500	6.666
CCR22-500	5000x1800x500	7.120
CCR22-550	5500x1800x500	8.027
CCR22-600	6000x1800x500	8.673

STRAIGHT CENTRAL EXTRACTOR CANOPY WITH PLENUM

Model	Dimensions	RRP (€)
CCR22-200H	2000x1800x725	3.800
CCR22-250H	2500x1800x725	4.294
CCR22-300H	3000x1800x725	5.258
CCR22-350H	3500x1800x725	5.534
CCR22-400H	4000x1800x725	6.659
CCR22-450H	4500x1800x725	7.155
CCR22-500H	5000x1800x725	7.635
CCR22-550H	5500x1800x725	8.613
CCR22-600H	6000x1800x725	9.297

STRAIGHT CENTRAL EXTRACTOR CANOPY WITH REGULATING PLENUM

Model	Dimensions	RRP (€)
CCR22-200P	2000x1800x725	4.191
CCR22-250P	2500x1800x725	4.738
CCR22-300P	3000x1800x725	5.803
CCR22-350P	3500x1800x725	6.148
CCR22-400P	4000x1800x725	7.356
CCR22-450P	4500x1800x725	7.903
CCR22-500P	5000x1800x725	8.435
CCR22-550P	5500x1800x725	9.517
CCR22-600P	6000x1800x725	10.275

NEW

COMPENSATED CENTRAL EXTRACTOR CANOPIES- 1800 DEEP



- Manufactured of satin finish AISI-304 18/10 stainless steel.
- Air output plenum with integrated grille.
- Welded extractor canopy with flattened edges for an easy and safe cleaning.
- Exterior roof manufactured of galvanized steel.
- Oil drainage with threaded plug.
- Solid anchor easy to install.
- Models with regulation integrate an interior plenum with individual adjustable sliding flaps.
- Extractor canopies longer than 3 metres are supplied in two pieces with a sturdy easy to assemble unseen jointing kit.
- Optional lighting, see page 127.
- Optional fire self-extinguishing system, see page 126.
- It includes AISI 430 stainless steel slats filters, 490x490x50mm.

COMPENSATED CENTRAL EXTRACTOR CANOPY

Model	Dimensions	RRP (€)
CCRC18-200H	2000x1800x725	3.745
CCRC18-250H	2500x1800x725	4.226
CCRC18-300H	3000x1800x725	5.165
CCRC18-350H	3500x1800x725	5.502
CCRC18-400H	4000x1800x725	6.568
CCRC18-450H	4500x1800x725	7.049
CCRC18-500H	5000x1800x725	7.530
CCRC18-550H	5500x1800x725	8.489
CCRC18-600H	6000x1800x725	9.175

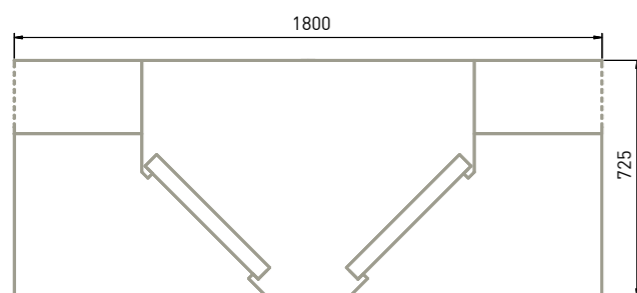

COMPENSATED CENTRAL EXTRACTOR CANOPY WITH REGULATING PLENUM

Model	Dimensions	RRP (€)
CCRC18-200P	2000x1800x725	4.086
CCRC18-250P	2500x1800x725	4.612
CCRC18-300P	3000x1800x725	5.639
CCRC18-350P	3500x1800x725	5.909
CCRC18-400P	4000x1800x725	7.174
CCRC18-450P	4500x1800x725	7.701
CCRC18-500P	5000x1800x725	8.227
CCRC18-550P	5500x1800x725	9.276
CCRC18-600P	6000x1800x725	10.026

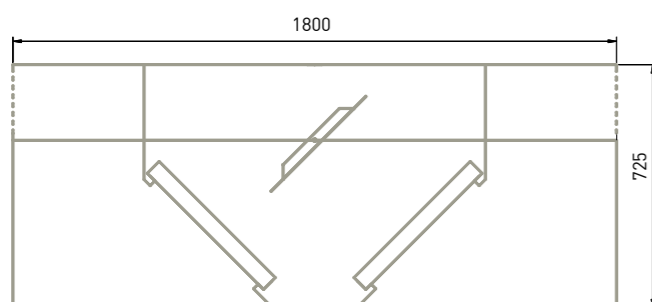

COMPENSATED CENTRAL OVEN EXTRACTOR CANOPIES- 2200 DEEP

NEW



- Manufactured of satin finish AISI-304 18/10 stainless steel.
- Air output plenum with integrated grille.
- Welded extractor canopy with flattened edges for an easy and safe cleaning.
- Exterior roof manufactured of galvanized steel.
- Oil drainage with threaded plug.
- Solid anchor easy to install.
- Models with regulation integrate an interior plenum with individual adjustable sliding flaps.
- Extractor canopies longer than 3 metres are supplied in two pieces with a sturdy easy to assemble unseen jointing kit.
- Optional lighting, see page 127.
- Optional fire self-extinguishing system, see page 126.
- It includes AISI 430 stainless steel slats filters, 490x490x50mm.

CENTRAL OVEN EXTRACTOR CANOPY

Model	Dimensions	RRP (€)
CCRC22-200H	2000x2200x725	4.072
CCRC22-250H	2500x2200x725	4.596
CCRC22-300H	3000x2200x725	5.620
CCRC22-350H	3500x2200x725	5.979
CCRC22-400H	4000x2200x725	7.149
CCRC22-450H	4500x2200x725	7.672
CCRC22-500H	5000x2200x725	8.196
CCRC22-550H	5500x2200x725	9.243
CCRC22-600H	6000x2200x725	9.989

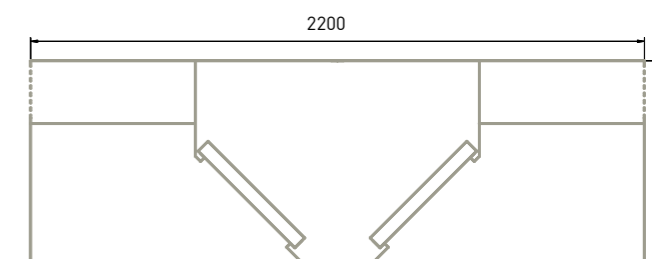

CENTRAL OVEN EXTRACTOR CANOPY WITH REGULATING PLENUM

Model	Dimensions	RRP (€)
CCRC22-200P	2000x2200x725	4.413
CCRC22-250P	2500x2200x725	4.982
CCRC22-300P	3000x2200x725	6.094
CCRC22-350P	3500x2200x725	6.386
CCRC22-400P	4000x2200x725	7.755
CCRC22-450P	4500x2200x725	8.324
CCRC22-500P	5000x2200x725	8.892
CCRC22-550P	5500x2200x725	10.029
CCRC22-600P	6000x2200x725	10.840

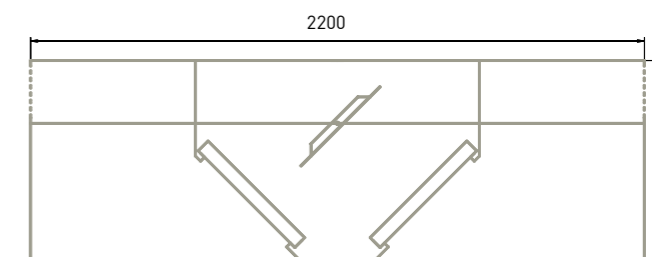

AUTOMATIC FIRE-EXTINGUISHER SYSTEM

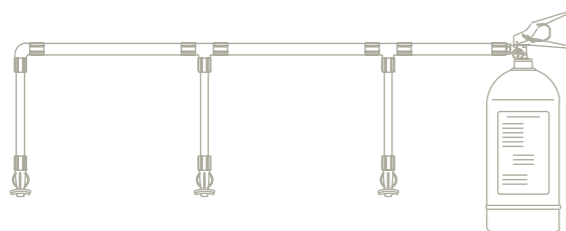

- Homologated and certified system which complies with the fire extinction in extractor canopies regulations currently in force.
- Totally autonomous, without electric supply necessity. Very safe and effective.
- Biodegradable, ecological and innocuous exterior fluid stored in a cylindrical deposit.
- Sprinklers with thermal excitement actuator vial.
- Easy to activate and with minimum maintenance demand by authorized service.
- Deposit situated on the exterior lateral of the canopy.

WALL

Model	L	Deposit	Sprinklers	RRP (€)
EI-CM-100I	1000	Left lateral	1	1.452
EI-CM-100D	1000	Right lateral	1	1.452
EI-CM-150I	1500	Left lateral	2	1.554
EI-CM-150D	1500	Right lateral	2	1.554
EI-CM-200I	2000	Left lateral	2	1.655
EI-CM-200D	2000	Right lateral	2	1.655
EI-CM-250I	2500	Left lateral	3	1.741
EI-CM-250D	2500	Right lateral	3	1.741
EI-CM-300I	3000	Left lateral	4	1.878
EI-CM-300D	3000	Right lateral	4	1.878
EI-CM-350I	3500	Left lateral	4	2.104
EI-CM-350D	3500	Right lateral	4	2.104
EI-CM-400I	4000	Left lateral	4	2.104
EI-CM-400D	4000	Right lateral	4	2.104
EI-CM-450I	4500	Left lateral	5	2.206
EI-CM-450D	4500	Right lateral	5	2.206
EI-CM-500I	5000	Left lateral	6	2.206
EI-CM-500D	5000	Right lateral	6	2.206
EI-CM-550I	5500	Left lateral	7	2.307
EI-CM-550D	5500	Right lateral	7	2.307
EI-CM-600I	6000	Left lateral	7	2.307
EI-CM-600D	6000	Right lateral	7	2.307

CENTRAL

Model	L	Deposit	Sprinklers	RRP (€)
EI-CC-150	1500	Lateral	2+2	2.654
EI-CC-200	2000	Lateral	2+2	2.857
EI-CC-250	2500	Lateral	3+3	3.028
EI-CC-300	3000	Lateral	4+4	3.302
EI-CC-350	3500	Lateral	4+4	3.896
EI-CC-400	4000	Lateral	4+4	4.208
EI-CC-450	4500	Lateral	5+5	4.411
EI-CC-500	5000	Lateral	6+6	4.411
EI-CC-550	5500	Lateral	7+7	4.615

INTEGRATED TURBINES 400°C/2h

- Multi-blade turbine, with double inlet forward-curved blades.
- Vibration-proof system and silentblocks.
- Units suitable for operation in fire risk areas 400°C/2h.
- Homologation complying with norm EN 12101-3:2002.



Model	Power (Kw)	R.P.M.	Max. flow . (m³/h)	RRP (€)
TI400 9/9-6M 1/3 cv	0,25	900	2100	1.447
TI400 9/9-6T 1/3 cv	0,25	920	2100	1.447
TI400 9/9-4M 3/4 cv	0,55	1410	3000	1.492
TI400 9/9-4T 3/4 cv	0,55	1420	3000	1.498
TI400 10/10-6M 1/3 cv	0,25	900	2250	1.483
TI400 10/10-4M 3/4 cv	0,55	1410	3450	1.563
TI400 10/10-4T 3/4 cv	0,55/0,15	1440/710	3450	1.534
TI400 12/12-6M 1 cv	0,75	920	4800	1.823
TI400 12/12-6M 1,5 cv	1,1	920	6200	1.936

INTEGRATED TURBINES

- Multi-blade turbine, with double inlet forward-curved blades.
- Vibration-proof system by means of bending arms and silent-blocks.
- Maximum operation temperature: continuous 50°C

Model	Power (KW)	R.P.M.	Sound level (dB)	Max. flow (m³/h)	RRP (€)
TI 9/9 1/5 cv	0,15	850	60	2200	260
TI 9/9 1/2 cv	0,37	1320	66	2800	278
TI 9/9 3/4 cv	0,55	1310	70	3600	285
TI 10/10 1/3 cv	0,25	830	62	3200	288
TI 10/10 3/4 cv	0,55	1310	70	3950	295
TI 12/9 1 cv	0,75	850	69	5500	417
TI 12/12 1,5 cv T	1,1	850	75	7800	468



TURBINE STANDS

Model	For turbines	RRP (€)
ST-9/9	9/9	102
ST-10/10	10/10	102
ST-12/12	12/12	136



LIGHTING

SURFACE LIGHTING

- Airtight surface lighting IP68 with polycarbonate body and silicone wiring.
- It includes fluorescent tubes.



EMBEDDED LIGHTING

NEW

- Embedded lighting with water-proof, dust-proof installation IP-68.
- Manufactured of stainless steel AISI-304 18/10.
- High resistance tempered glass integrated.
- Lighting by means of lamp strips Led T5 style.
- This lighting system is supplied ex-works assembled in the canopy.

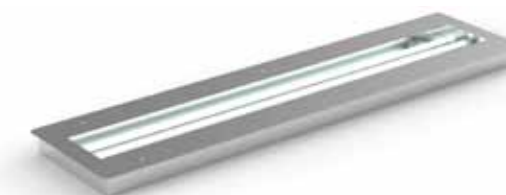

Model	Dimensions	Watts	RRP (€)
LS70-18	700xØ100	18	238
LS130-36	1300xØ100	36	304

Model	Dimensions	Watts	RRP (€)
LE -70	706x236x55	25	395
LE-130	1306x236x55	50	430

WALL EXTRACTOR CANOPY SHELF

- Manufactured of stainless steel AISI-304 18/10.
- Removable grilles to facilitate its cleaning.
- Easy and quick assemble (screws and plugs included).

Model	Dimensions	RRP (€)
EMC-1GN	585x380	263
EMC-2GN	1115x380	324
EMC-3GN	1650x380	375
EMC-4GN	2180x380	423



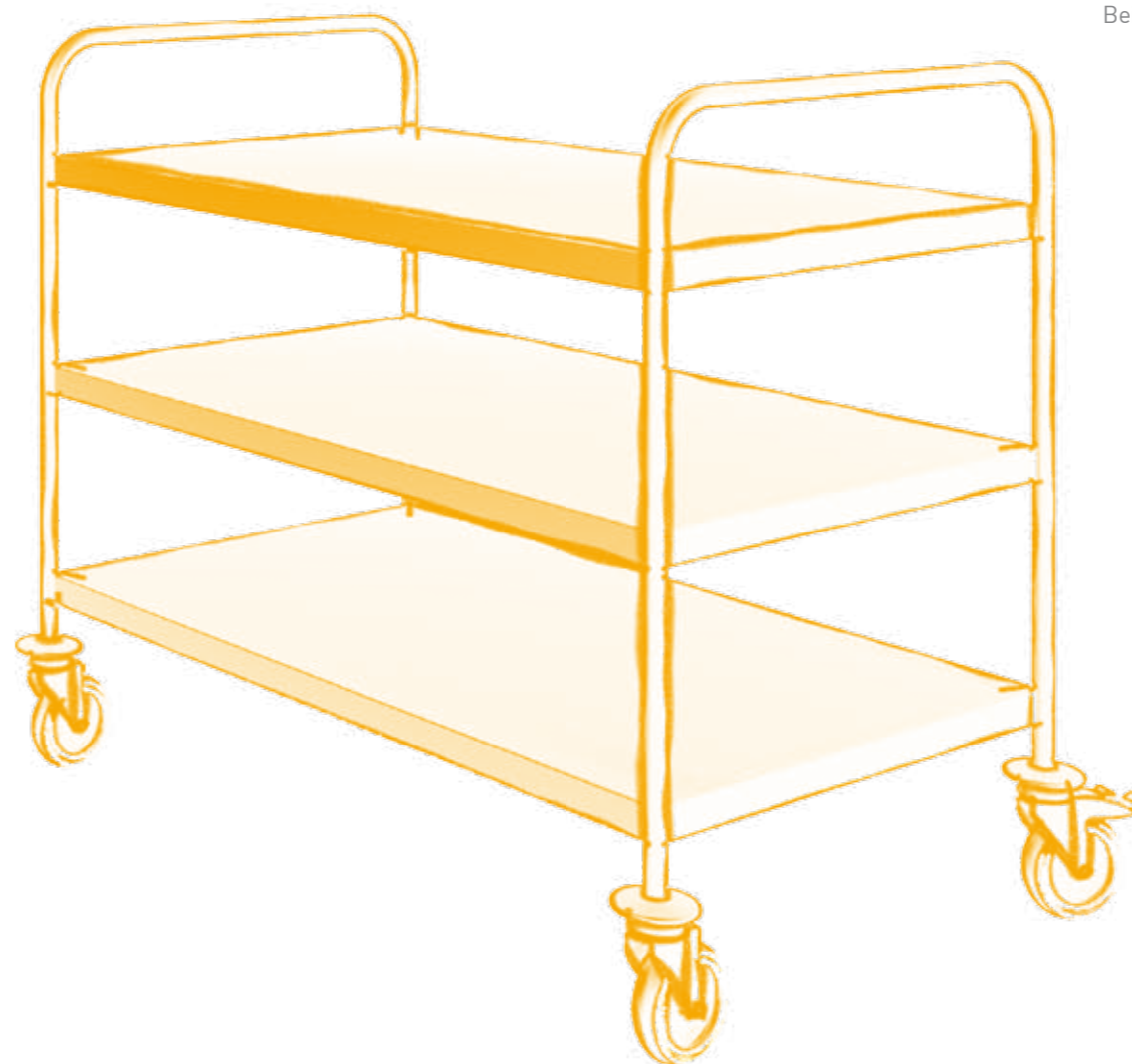

NEUTRAL AND HEATED TROLLEYS

Stainless steel service trolleys	page 130
Aluminium and polypropylene service trolleys	page 131
Baskets trolleys	page 131
Stainless steel bin with wheels	page 131
Tall gastronorm trolleys	page 132
Tall pastry trolley	page 132
Self-service baskets trolley	page 132
Low gastronorm trolleys	page 133
Low pastry trolley	page 133
Plates trolley	page 133
Protective cover for trolleys	page 133
Heated trolleys	page 134
Heated trolleys with embedded slides	page 136
Bein-marie trolleys	page 137

STAINLESS STEEL SERVICE TROLLEYS



- Utterly manufactured of satin stainless steel AISI-304 18/10.
- Sturdy, reinforced structure, manufactured of 1.5mm thick tube.
- Very robust sound-proof shelves without cutting edges thanks to their special assembly and folding.
- 4 sound-proof swivelling wheels, Ø125mm (2 with brakes), equipped with metallic support and stain-proof rubber bumper.
- Capacity to hold 80kg/shelf, with a maximum of 250kg/trolley (for distributed loads).

2 SHELVES

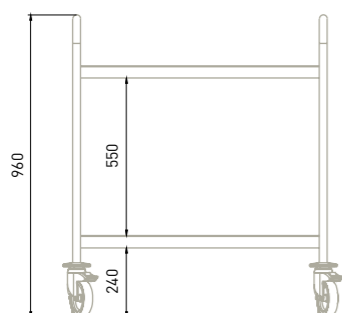

DISMOUNTED

Model	Shelves measurements	Nº of shelves	Dimensions	RRP (€)
CSD-82	800x500	2	880x580x960	307
CSD-92	900x500	2	980x580x960	306
CSD-102	1000x600	2	1080x680x960	377

MOUNTED AND WELDED

Model	Shelves measurements	Nº of shelves	Dimensions	RRP (€)
CS-82	800x500	2	880x580x960	382
CS-92	900x500	2	980x580x960	381
CS-102	1000x600	2	1080x680x960	452

3 SHELVES

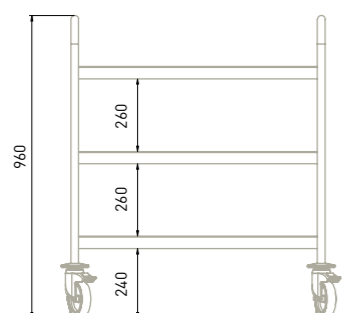

DISMOUNTED

Model	Shelves measurements	Nº of shelves	Dimensions	RRP (€)
CSD-83	800x500	3	880x580x960	377
CSD-93	900x500	3	980x580x960	390
CSD-103	1000x600	3	1080x680x960	496

MOUNTED AND WELDED

Model	Shelves measurements	Nº of shelves	Dimensions	RRP (€)
CS-83	800x500	3	880x580x960	457
CS-93	900x500	3	980x580x960	470
CS-103	1000x600	3	1080x680x960	576

ALUMINIUM AND POLYPROPYLENE SERVICE TROLLEYS

- Economic, light and resistant trolleys.
- Structure manufactured of anodized aluminium, with integrated handle.
- Solid shelves manufactured of injected polypropylene.
- 4 sound-proof swivelling wheels, Ø125mm (2 with brakes), equipped with metallic support and stain-proof rubber bumper.
- Capacity to hold 65kg/shelf, with a maximum of 180kg/trolley (for distributed loads).
- Supplied unassembled. Quick and easy assembly

3 SHELVES

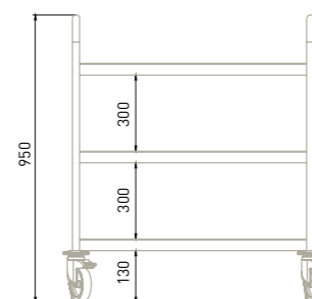

Model	Shelves measurements	Nº de estantes	Dimensiones	P.V.P. (€)
CSP-83	625x410	3	890x415x950	158
CSP-103	795x495	3	1045x500x950	203

BASKETS TROLLEYS

- Designed for baskets transportation, 500x500mm.
- Solid stainless steel structure.
- Thermoformed shelf, ABS.
- 4 sound-proof swivelling wheels, Ø125mm (2 with brakes), equipped with metallic support and stain-proof rubber bumper.
- Integrated handle in model CPC-M.
- Supplied unassembled. Quick and easy assembly.



Model	Dimensions	Handlebar	RRP (€)
CPC	540x540x315	No	200
CPC-M	630x540x945	Yes	246

STAINLESS STEEL BIN WITH WHEELS

- Manufactured of stainless steel AISI-304 18/10.
- Embedded bottom to facilitate cleaning.
- Models CC-50 and CC-100 with removable lid.
- Models CCP-100 and SB-100 are equipped with pedal operation lid.
- Available in two capacities: 50 and 100L.
- With wheels Ø50 mm.

Model	Dimensions	Description	RRP (€)
CC-50	Ø380x605 (50 L.)	Without pedal	179
CC-100	Ø450x685 (100 L.)	Without pedal	210
CCP-100	Ø450x685 (100 L.)	With pedal	248
SB-100	Ø410x850 (100 L.)	Bag support with pedal	235





TALL GASTRONORM TROLLEYS

- Manufactured of satin stainless steel.
- Utterly welded slides with stoppers.
- 4 sound-proof swivelling wheels, Ø125mm (2 with brakes), equipped with metallic support and stain-proof rubber bumper.
- Equipped with 20 pairs of slides, 75mm apart, for GN trays. (Trays not included), see page 141.

DISMOUNTED

Model	Dimensions	Nº of slides	Trays	RRP (€)
CGAD-11	440x615x1855	20	GN 1/1	369
CGAD-21	645x735x1855	20	GN 2/1	494

MOUNTED AND WELDED

Model	Dimensions	Nº of slides	Trays	RRP (€)
CGA-11	440x615x1855	20	GN 1/1	424
CGA-21	645x735x1855	20	GN 2/1	554

TALL PASTRY TROLLEY

- Manufactured of satin stainless steel.
- Utterly welded slides with stoppers.
- 4 sound-proof swivelling wheels, Ø125mm (2 with brakes), equipped with metallic support and stain-proof rubber bumper.
- Equipped with 20 pairs of slides, 75mm apart, for GN trays. (Trays not included), see page 141.

DISMOUNTED

Model	Dimensions	Nº of slides	Trays	RRP (€)
CPAD-64	515x685x1855	20	600 x 400	397

MOUNTED AND WELDED

Model	Dimensions	Nº of slides	Trays	RRP (€)
CPA-64	515x685x1855	20	600 x 400	457

NEW

SELF-SERVICE BASKETS TROLLEY

- Manufactured of satin stainless steel.
- It holds 290/38mm wide and 530mm deep trays.
- Utterly welded slides with stoppers.
- 4 sound-proof swivelling wheels, Ø125mm (2 with brakes), equipped with metallic support and stain-proof rubber bumper.

DISMOUNTED

Dimensions	Nº of slides	DISMOUNTED		WELDED	
		Model	RRP. (€)	Model	RRP. (€)
445x565x1825	12	CBAD-12	457	CBA-12	502
860x565x1825	24	CBAD-24	619	CBA-24	694



LOW GASTRONORM TROLLEYS

- Manufactured of satin stainless steel.
- Utterly welded slides with stoppers.
- It incorporates sound-proof countertop.
- 4 sound-proof swivelling wheels, Ø125mm (2 with brakes), equipped with metallic support and stain-proof rubber bumper.
- Equipped with 20 pairs of slides, 75mm apart, for GN trays. (Trays not included), see page 141.

DISMOUNTED

Trays	Dimensions	Nº of slides	DISMOUNTED		WELDED	
			Model	RRP (€)	Model	RRP (€)
GN 1/1	440x615x860	7	CGBD-11	269	CGB-11	314
GN 2/1	650x740x860	7	CGBD-21	344	CGB-21	394

LOW PASTRY TROLLEY

- Manufactured of satin stainless steel.
- Utterly welded slides with stoppers.
- It incorporates sound-proof countertop.
- 4 sound-proof swivelling wheels, Ø125mm (2 with brakes), equipped with metallic support and stain-proof rubber bumper.
- Equipped with 20 pairs of slides, 75mm apart, for GN trays. (Trays not included), see page 141.

DISMOUNTED

Trays	Dimensions	Nº of slides	DISMOUNTED		WELDED	
			Model	RRP (€)	Model	RRP (€)
60x40	685x515x860	7	CPBD-64	366	CPB-64	411

PLATES TROLLEY

- Utterly welded structure, manufactured of steel with antioxidant treatment and black epoxy finish.
- The structure integrates a central arch which enables a comfortable movement and provides it with a better robustness.
- Its design allows the adjustability to plates of different sizes, up to a maximum of Ø33cm.
- Height separation between plates: 60mm.
- 4 sound-proof swivelling wheels, Ø125mm (2 with brakes), equipped with metallic support and stain-proof rubber bumper.
- Capacity for 100 plates.

Model	Dimensions	Capacity	RRP (€)
CPL-100	757x757x1810	100 dishes	636

PROTECTIVE COVER FOR TROLLEYS

- Ideal for the protection of food until service.
- Manufactured of sanitary plastic.
- Zip closing and reinforced edges.
- Hand washable.

Model	Description	RRP (€)
FPCGA-11	Vinotec cover for tall trolley GN1/1	122
FPCGA-21	Vinotec cover for tall trolley GN2/1	129
FPCPA-64	Vinotec cover for tall pastry trolley	138
N FPCPL-100	Vinotec cover for plates trolley CPL-100	219



HEATED TROLLEYS WITH HUMIDITY CONTROL



- Utterly manufactured of stainless steel AISI-304 18/10 with reinforced structure and components.
- Maximum energetic efficiency thanks to its integral fire-proof high density ecologic polyurethane insulation of great thickness.
- Door equipped with key locks, 270° opening and metal reinforced hinges.
- Ergonomic oversized handle, equipped with key lock.
- Embedded interior slides. Separation between slides: 70mm.
- Perimeter bumper.
- Removable tight silicone weather strip, manufactured in one piece with rounded corners.
- Sound-proof wheels, Ø125mm (2 with brakes).
- Large stainless steel back handles.
- Digital panel with separated humidity and temperature control.
- Single-phase 230v / 50Hz.



Model CHS-20 GN2/1-G



Model CHS-20 GN1/1-G



Model CHS-20 GN2/1



Model CHS-20 GN1/1



Model CHS-10 GN2/1

Model	Dimensions	N. of slides	Glass door	Type	Power (W)	RRP (€)
CHS-20 GN2/1-G	730x950x1800	20 GN2/1	Yes	Tall	2100	3578
CHS-20 GN1/1-G	530x850x1800	20 GN1/1	Yes	Tall	2100	3330
CHS-20 GN2/1	730x950x1800	20 GN2/1	No	Tall	2100	3202
CHS-20 GN1/1	530x850x1800	20 GN1/1	No	Tall	2100	2987
CHS-10 GN2/1	730x950x1100	10 GN2/1	No	Low	1600	2640

COOLED TROLLEYS

- Utterly manufactured of stainless steel AISI-304 18/10 with reinforced structure and components.
- Maximum energetic efficiency thanks to its integral fire-proof high density ecologic polyurethane insulation of great thickness.
- Door equipped with key locks, 270° opening and metal reinforced hinges.
- Ergonomic oversized handle, equipped with key lock.
- Embedded interior slides. Separation between slides: 70mm.
- Perimeter bumper.
- Removable tight silicone weather strip, manufactured in one piece with rounded corners.
- Sound-proof wheels, Ø125mm (2 with brakes).
- Large stainless steel back handles.
- Removable tight silicone weather strip, manufactured in one piece with rounded corners.
- Control panel with adjustable digital thermometer/thermostat of 30 to 90°C.
- Refrigerated by means of ventilated evaporator, condenser unit with gas R290 and thermostat digital control.
- Removable condenser unit, which makes its maintenance and cleanness easy.
- Single-phase 230v / 50Hz.



Model CFS-18 GN2/1



Model CFS-18 GN1/1



Model CFS-10 GN2/1

Model	Dimensions	N. of slides	Type	Power (W)	RRP (€)
CFS-18 GN2/1	730x950x1800	18 GN2/1	Tall	250	3921
CFS-18 GN1/1	530x850x1800	18 GN1/1	Tall	250	3692
CFS-10 GN2/1	730x950x1300	10 GN2/1	Low	200	3275

HEATED TROLLEYS



- Utterly manufactured of stainless steel AISI-304 18/10 with reinforced structure and components.
- Maximum energetic efficiency thanks to its integral fire-proof high-density ecologic polyurethane insulation of great thickness.
- Doors equipped with key locks, 180° opening.
- Zips and slides easily removable. Separation between slides: 53 to 70mm (Grilles/trays not included).
- Removable tight silicone weather strip, manufactured in one piece with rounded corners.
- Sound-proof wheels, Ø125mm (2 with brakes).
- Removable heating block with ventilated resistances and humidity trays with no-spill system.
- Security thermal protection by means of klixon.
- Control panel with illuminated switch and adjustable digital thermometer/thermostat of 30 to 90°C.
- Single-phase 230v operation temperature, 50-60Hz.

LOW HEATED TROLLEYS

Model	Dimensions	Nº of slides	Separation between slides (mm)	Power (W)	RRP (€)
N CC-5 GN	770x850x850	5 GN 2/1	70	1650	1817
CC-10 GN	770x850x1240	10 GN 2/1	70	2100	2196

TALL ONE-PIECE HEATED TROLLEYS

Model	Dimensions	Nº of slides	Separation between slides (mm)	Power (W)	RRP (€)
N CC-17 GN1/1	565 x760x1700	17 GN 1/1	70	2100	2448
N CC-22 GN1/1	565 x760x1700	22 GN 1/1	53	2100	2484
CC-17 GN	770x850x1700	17 GN 2/1	70	2600	2616
CC-22 GN	770x850x1700	22 GN 2/1	53	2600	2652

TALL TWO-PIECE HEATED TROLLEYS

Model	Dimensions	Nº of slides	Separation between slides (mm)	Power (W)	RRP (€)
CC-34 GN	1470x850x1700	34 GN 2/1	70	3350	4.302
CC-39 GN	1470x850x1700	17 GN 2/1	70	3350	4.266
		22 GN 2/1	53		
CC-44 GN	1470x850x1700	44 GN 2/1	53	3350	4.230

BEIN-MARIE TROLLEYS



- Utterly manufactured of stainless steel AISI-304 18/10.
- Utterly welded well with rounded sanitary edges.
- Fire-proof ecologic polyurethane insulation.
- Adjustable operating temperature +30°/+90°C.
- Control panel with adjustable digital thermometer/thermostat and illuminated switch.
- Security thermal protection by means of klixon.
- Single-phase 230v operation temperature, 50Hz.
- 4 swivelling wheels, (2 with brakes).
- Lower shelf not included.

HUMID BEIN-MARIE TROLLEYS

- Well heating by means of silicone resistances which improve their performance and reduce electrical consumption.
- Apt for GN wells of up to 150mm deep.
- Drainage faucet 1/2" with ball valve and removable drainage tube.

Model	Dimensions	Trays	Power	RRP (€)
CBMH-2GN	790x690x945	2 GN 1/1-150	1000 W	1.483
CBMH-3GN	1120x690x945	3 GN 1/1-150	2000 W	1.747
CBMH-4GN	1445x690x945	4 GN 1/1-150	3000 W	2.144
CBMH-5GN	1770x690x945	5 GN 1/1-150	3000 W	2.566

DRY BEIN-MARIE TROLLEYS

- Well heating by means of shielded resistances protected by drilled double bottom and removable for its better cleaning.
- Apt for GN wells of up to 100mm deep (not included).

Model	Dimensions	Trays	Power	RRP (€)
CBMS-2GN	790x690x945	2 GN 1/1-100	800 W	1.351
CBMS-3GN	1120x690x945	3 GN 1/1-100	1200 W	1.503
CBMS-4GN	1445x690x945	4 GN 1/1-100	1600 W	1.868
CBMS-5GN	1770x690x945	5 GN 1/1-100	2000 W	2.279



GASTRONORM CONTAINERS

Plain wells	page 141
Wells with handles	page 141
Drilled wells	page 142
Lids for plain wells	page 142
Lids for wells with handles	page 142
Tight lids for wells	page 142
Dividing profiles	page 143
Drilled bottoms	page 143
Stainless steel grilles	page 143
Laminated steel grilles	page 143
Ice cream wells	page 143
Dishwasher	page 143



- Manufactured of stainless steel AISI 304 18/10.
- ERATOS Gastronorm containers are distinguished by their high quality and durability.
- Greatly stable burr-free edges.
- Maximum hygiene and robustness thanks to ample curve radii.
- Resistant to temperatures between -40°C and +280°C.
- Designed and manufactured complying with the European norm EN-631.
- GNA models include retractable handles to facilitate their transport.
- Stackable containers for a better use of space.

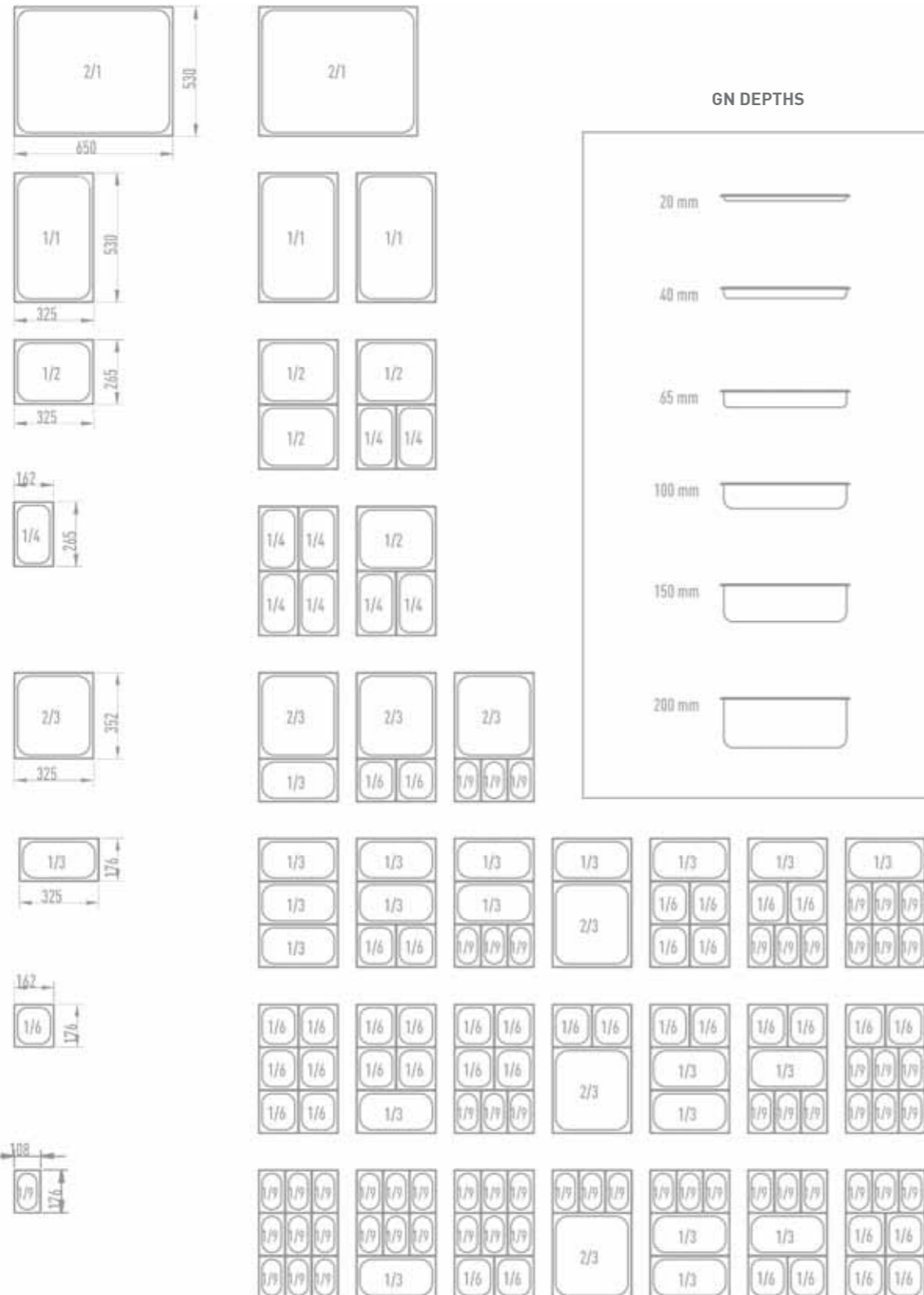

PLAIN WELLS **WELLS WITH HANDLES**



Size	Depth (mm.)	Capacity (L)	Model	RRP (€)	Model	RRP (€)
GN 2/1 646x530 mm	20	5,0	GN2/1-20	39,20		
	40	10,0	GN2/1-40	43,70		
	65	18,5	GN2/1-65	50,80	GNA2/1-65	57,00
	100	28,5	GN2/1-100	60,90	GNA2/1-100	66,40
	150	42,5	GN2/1-150	93,80	GNA2/1-150	113,00
	200	57,5	GN2/1-200	116,70	GNA2/1-200	131,00
GN 1/1 325x530 mm	20	3,0	GN1/1-20	17,50		
	40	5,0	GN1/1-40	20,60		
	65	9,0	GN1/1-65	23,30	GNA1/1-65	31,00
	100	14,0	GN1/1-100	29,90	GNA1/1-100	37,30
	150	21,0	GN1/1-150	44,50	GNA1/1-150	54,30
	200	28,0	GN1/1-200	51,60	GNA1/1-200	68,80
GN 2/3 325x352 mm	20	1,5	GN2/3-20	21,80		
	40	3,0	GN2/3-40	22,50		
	65	5,5	GN2/3-65	24,40	GNA2/3-65	32,60
	100	9,0	GN2/3-100	29,80	GNA2/3-100	38,80
	150	13,0	GN2/3-150	37,70	GNA2/3-150	46,30
	200	18,0	GN2/3-200	44,70	GNA2/3-200	53,30
GN 1/2 325x265 mm	20	1,3	GN1/2-20	14,80		
	40	2,0	GN1/2-40	15,60		
	65	4,5	GN1/2-65	16,50	GNA1/2-65	24,90
	100	6,0	GN1/2-100	21,40	GNA1/2-100	29,50
	150	9,0	GN1/2-150	29,80	GNA1/2-150	39,30
	200	12,5	GN1/2-200	36,80	GNA1/2-200	44,80
GN 1/3 325x176 mm	20	0,8	GN1/3-20	13,60		
	40	1,5	GN1/3-40	14,20		
	65	2,5	GN1/3-65	15,60	GNA1/3-65	23,50
	100	4,0	GN1/3-100	19,20	GNA1/3-100	28,20
	150	5,7	GN1/3-150	25,70	GNA1/3-150	35,00
	200	7,8	GN1/3-200	30,50	GNA1/3-200	39,30
GN 1/4 162x265 mm	20	0,5	GN1/4-20	13,60		
	65	1,8	GN1/4-65	14,20	GNA1/4-65	20,20
	100	2,8	GN1/4-100	19,40	GNA1/4-100	26,50
	150	4,0	GN1/4-150	23,60	GNA1/4-150	33,10
	200	5,5	GN1/4-200	30,50	GNA1/4-200	39,30
GN 1/6 162x176 mm	65	1,0	GN1/6-65	13,10	GNA1/6-65	20,40
	100	1,6	GN1/6-100	15,00	GNA1/6-100	22,70
	150	2,4	GN1/6-150	18,80	GNA1/6-150	26,40
	200	3,4	GN1/6-200	30,50	GNA1/6-200	35,90
GN 1/9 108x176 mm	65	0,6	GN1/9-65	15,30		
	100	1,0	GN1/9-100	16,20		

The drilled trays, besides facilitating the draining of food, are perfect to save energy when making stews, scalding, boiling or steaming as they shorten cooking times and accelerate cooling.



DRILLED TRAYS

Size	Depth (mm.)	Capacity (L)	Model	RRP (€)
GN 2/1 646x530 mm	65	18,5	GNP2/1-65	77,80
	100	28,5	GNP2/1-100	118,00
	150	42,5	GNP2/1-150	169,00
	200	57,5	GNP2/1-200	208,00
GN 1/1 325x530 mm	65	9,0	GNP1/1-65	45,60
	100	14,0	GNP1/1-100	57,00
	150	21,0	GNP1/1-150	76,80
GN 1/2 325x265 mm	65	4,5	GNP1/2-65	30,30
	100	6,0	GNP1/2-100	41,50
	150	9,0	GNP1/2-150	47,50
	200	12,5	GNP1/2-200	61,50



LIDS FOR PLAIN WELLS

Model	Dimensions	RRP (€)
GNT 1/1	530x325	21,20
GNT 2/3	352x325	18,00
GNT 1/2	325x265	14,00
GNT 1/3	325x176	12,30
GNT 1/4	265x162	11,10
GNT 1/6	176x162	9,80
GNT 1/9	176x109	8,80



LIDS FOR WELLS WITH HANDLES

Model	Dimensions	RRP (€)
GNTA 2/1	650x530	51,20
GNTA 1/1	530x325	24,40
GNTA 2/3	352x325	21,20
GNTA 1/2	325x265	17,00
GNTA 1/3	325x176	13,80
GNTA 1/4	265x162	11,70
GNTA 1/6	176x162	10,80



TIGHT LIDS FOR WELLS

Model	Dimensions	RRP (€)
GNTH 1/1	530x325	74,00
GNTH 2/3	352x325	52,50
GNTH 1/2	325x265	49,20
GNTH 1/3	325x176	42,20
GNTH 1/4	265x162	41,80

DIVIDING PROFILES

Model	Dimensions	RRP (€)
GND 2/1	530	17,30
GND 1/1	325	14,90



DRILLED BOTTOMS

Model	Dimensions	RRP (€)
GNF 1/1	465x265	41,30
GNF 1/2	265x220	27,70
GNF 1/3	265x115	27,00



STAINLESS STEEL GRILLES

Model	Dimensions	Type	RRP (€)
PI 2/1	650x530	GN 2/1	38,90
PI 1/1	325x530	GN 1/1	19,30

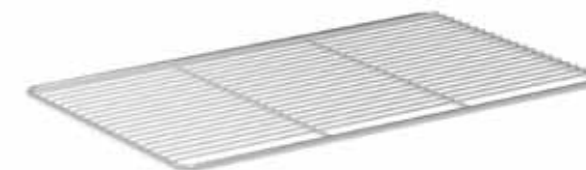

LAMINATED STEEL GRILLES

Model	Dimensions	Type	RRP (€)
PP 2/1	650x530	GN 2/1	16,60
PP 1/1	325x530	GN 1/1	10,50

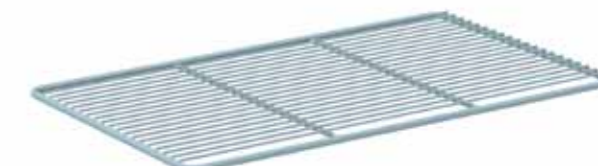

ICE CREAM WELLS

Model	Dimensions	Capacity	RRP (€)
GH-5	360x165x120	5 Litres	23,70
GH-7	360x165x150	7 Litres	28,70
GHT	360x165	Methacrylate lid	9,90



DISHERWASHER

- Manufactured of stainless steel AISI 304 18/10
- Inset cover for the washing of ice cream dishes.
- It integrates a water inlet in its lower part 3/8" and a water outlet 1/2".

Model	Dimensions	Embedding hole	RRP (€)
LP	110x270x145	255x95	75,70



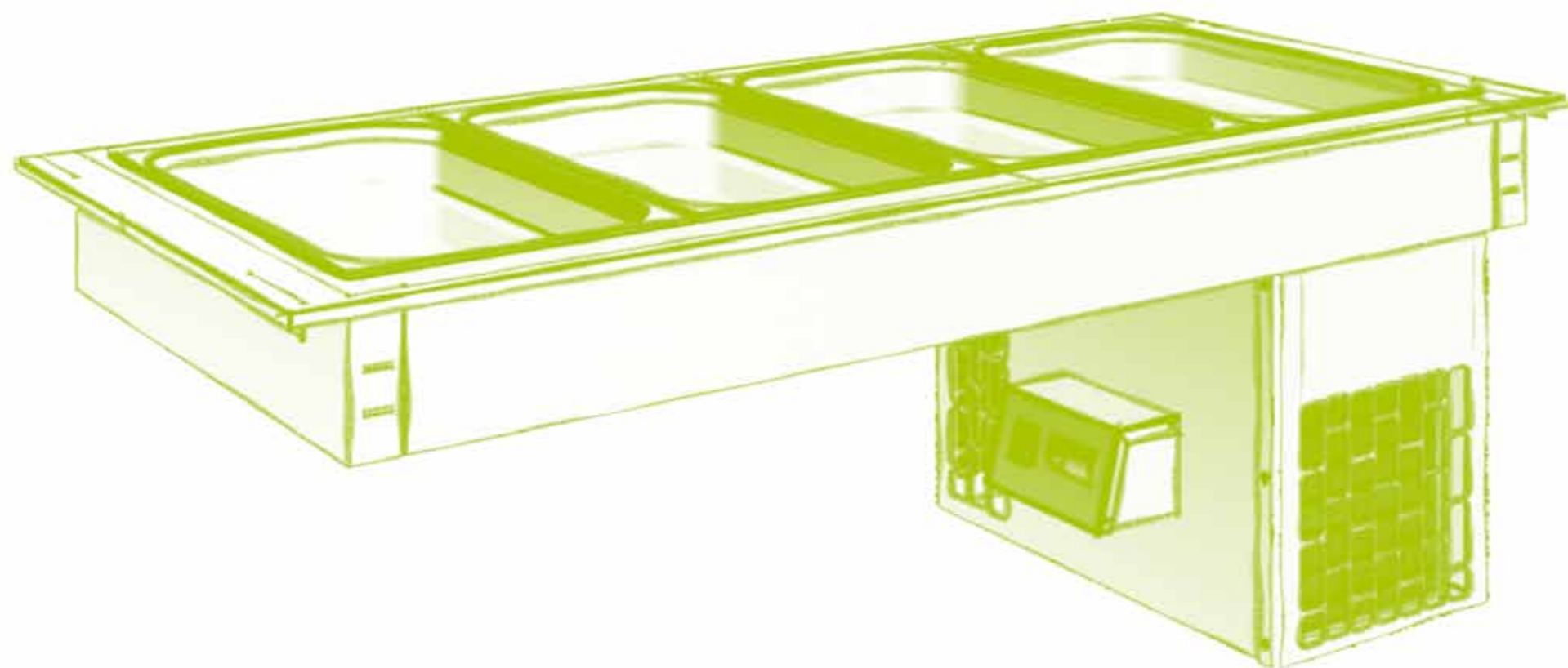

DROP-IN ELEMENTS AND MODULAR FURNITURE

Cooled Drop-in elements	page 148
Cooled Drop-in showcases.....	page 152
Hot Drop-in elements	page 155
Tempered glass tabletop hot plates.....	page 158
Warming unit	page 158
Lamp strip and heat lamp strip for Drop-in and Buffet equipment	page 160
Curved, straight, frontal sneeze guards for Drop-in and Buffet units	page 162
Neutral brackets for Drop-in and Buffet sneeze guards.....	page 163
Buffet modular furniture for Drop-in elements installation	page 167
Buffet module for Drop-in, 85 deep	page 168
Buffet module for Drop-in, 110 deep	page 169
Buffet module for show cooking	page 170
Buffet module for show-cooking, 125 deep	page 171
Show-cooking Buffet module , 125 deep	page 171
Decoration and countertop changes for Buffet and show-cooking modules...	page 172
Optional front decoration for Buffet and show-cooking modules	page 173

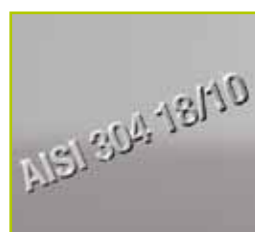

Maximum quality
Products manufactured of high quality AISI 304 18/10 stainless steel equipped with European manufactured superior components and designed for an intensive professional long-lasting use.



Integration
ERATOS Drop-in range enables the easy integration of buffet and self-service equipment to a functional level and the client's aesthetic, based on standard elements easy to fit in.



Easy to install
The Drop-in elements only need connection to electricity and/or pipes. Units can be installed onto the Drop-in equipment and control panel is mobile and detachable.



Finish and design
Top range finish and design details. Metal hardware, tempered glass, hanging doors, perfect adjustments. No welds, rivets, plastic or rails at sight.



Hygiene and ergonomics
All materials, used together with the ample sanitary edges applied to the surfaces, ensure extreme hygiene. All elements have been designed complying with ergonomics and enabling an easy use.



Efficiency and technology
ERATOS cooled and heated Drop-in units are highly efficient thanks to the engineering applied to its technical design and the use of coolant gasses and insulation of leading-edge technology.



Broad range and availability
Our extensive catalogue of Drop-in elements and units enables the choice of a proper element for each necessity. Our permanent stock ensures an immediate availability.



Options and accessories
We offer options, such as the "thermometer kit", which shows the temperature of the drop-in lower element. This range has numerous accessories that broaden its setting options.

COOLED BOARDS WITH REFRIGERATING UNIT

- Manufactured of satin stainless steel AISI-304 18/10.
- Embedded board, refrigerated by means of copper serpentine tubing.
- Coolant gas R-290. Optional gas R-134a for 2, 3 and 4GN or R452 for 5GN and 6GN.
- Board interval temperature -4°C/+4°C.
- High density and thickness ecologic injected insulation.
- Built-in drainage.
- 1-metre-long mobile control panel with digital thermometer/thermostat and illuminated switch. It contains a removable panel that can be placed on the exterior part of the module to facilitate the temperature view and the equipment control.
- Built-in condenser unit.
- Single-phase voltage 230v/50Hz



Model	Dimensions	Embedding dimensions	GN Capacity	Consumption (W)	Refrig.Power (W)	RRP (€)
PF2G-GI/R	790x646x430	765x625x420	2GN1/1	210	140	1.316
PF3G-GI/R	1120x646x430	1095x625x420	3GN1/1	300	240	1.342
PF4G-GI/R	1445x646x430	1420x625x420	4GN1/1	300	240	1.432
PF5G-GII/R	1770x646x430	1745x625x420	5GN1/1	570	625	1.577
PF6G-GI/R	2095x646x430	2070x625x420	6GN1/1	570	625	1.918

COOLED BOARDS

- Manufactured of satin stainless steel AISI-304 18/10.
- Embedded board, refrigerated by means of copper serpentine tubing. High density and thickness ecologic injected insulation.
- Built-in drainage.
- Expansion system of coolant gas not included.
- 1-metre-long mobile control panel with digital thermometer/thermostat and illuminated switch. It contains a removable panel that can be placed on the exterior part of the module to facilitate the temperature view and the equipment control.



Model	Dimensions	Embedding dimensions	GN Capacity	Compressor (CV)*	RRP (€)
PF2G /R	790x646x60	765x625x50	2GN1/1	1/5	910
PF3GI/R	1120x646x60	1095x625x50	3GN1/1	1/4	925
PF4G /R	1445x646x60	1420x625x50	4GN1/1	1/4	1.012
PF5GI/R	1770x646x60	1745x625x50	5GN1/1	1/3	1.156
PF6G /R	2095x646x60	2070x625x50	6GN1/1	1/3	1.397

* Compressor recommended for distances of up to 4 horizontal metres and coolant gas R-134a.

2-LEVEL COOLED BOARDS WITH BUILT-IN REFRIGERATING UNIT

NEW DESIGN

- Manufactured of satin stainless steel AISI-304 18/10.
- Copper serpentine tubing refrigerated board.
- Coolant gas R-290. Optional gas R-134a for 2, 3 and 4GN or R452A for 5GN.
- Board interval temperature -4°C/+4°C.
- High density and thickness ecologic injected insulation.
- Built-in drainage.
- 1-metre-long mobile control panel with digital thermometer/thermostat and illuminated switch. It contains a removable panel that can be placed on the exterior part of the module to facilitate the temperature view and the equipment control.
- Built-in condenser unit.
- Single-phase voltage 230v/50Hz



Model	Dimensions	Embedding dimensions	GN Capacity	Consumption (W)	Refrig.Power (W)	RRP (€)
PFD3G-GI/R	1120x646x500	1095x625x420	3GN1/1	300	240	1.696
PFD4G-GI/R	1445x646x500	1420x625x420	4GN1/1	300	240	1.783
PFD5G-GI/R	1770x646x500	1745x625x420	5GN1/1	570	625	1.988

2-LEVEL COOLED BOARDS WITHOUT REFRIGERATING UNIT

NEW DESIGN

- Manufactured of satin stainless steel AISI-304 18/10.
- Copper serpentine tubing refrigerated board.
- High density and thickness ecologic injected insulation.
- Built-in drainage.
- Expansion system of coolant gas not included.
- 1-metre-long mobile control panel with digital thermometer/thermostat and illuminated switch. It contains a removable panel that can be placed on the exterior part of the module to facilitate the temperature view and the equipment control.



Model	Dimensions	Embedding dimensions	GN Capacity	Compressor (CV)*	RRP (€)
PFD3GI/R	1120x646x130	1095x625x50	3 GN1/1	1/4	1.296
PFD4GI/R	1445x646x130	1420x625x50	4 GN1/1	1/4	1.383
PFD5GI/R	1770x646x130	1745x625x50	5 GN1/1	3/4	1.588

* Compressor recommended for distances of up to 4 horizontal metres and coolant gas R-134a.

ERATOS CATALOG 2020

STATIC COOLED WELLS WITH BUILT-IN REFRIGERATING UNIT

- Manufactured of satin stainless steel AISI-304 18/10.
- Well with rounded sanitary edges and drainage.
- Refrigerated with bottom and side copper serpentine tubing by means of high density and thickness ecologic injected insulation.
- Coolant gas R-290. Optional gas R-134a for 1, 2, 3 and 4GN or R452A for 5 y 6GN.
- Well interval temperature 0°C/+5°C.
- Designed for GN wells of up to 150mm deep (not included in the price).
- 1-metre-long mobile control panel with digital thermometer/thermostat and illuminated switch.
- Built-in condenser unit.
- Single-phase voltage 230v/50Hz

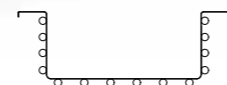

Bottom and sides copper serpentine tubing

Model	Dimensions	Embedding dimensions	GN Capacity	Consumption (W)	Refrig.Power (W)	RRP (€)
CF3G-6-GI/R	1120x646x500	1095x625x490	3GN1/1-65	300	240	1.453
CF4G-6-GI/R	1445x646x500	1420x625x490	4GN1/1-65	300	240	1.624
CF5G-6-GI/R	1770x646x500	1745x625x490	5GN1/1-65	570	625	1.816
CF6G-6-GI/R	2095x646x500	2070x625x490	6GN1/1-65	570	625	2.135
N CF1G-15-GI/R	465x646x580	445x625x570	1GN1/1-150	210	140	1.278
CF2G-15-GI/R	790x646x580	765x625x570	2GN1/1-150	210	140	1.384
CF3G-15-GI/R	1120x646x580	1095x625x570	3GN1/1-150	300	240	1.470
CF4G-15-GI/R	1445x646x580	1420x625x570	4GN1/1-150	300	240	1.641
CF5G-15-GI/R	1770x646x580	1745x625x570	5GN1/1-150	570	625	1.836
CF6G-15-GI/R	2095x646x580	2070x625x570	6GN1/1-150	570	625	2.180

STATIC COOLED WELLS

- Manufactured of satin stainless steel AISI-304 18/10.
- Well with rounded sanitary edges and drainage.
- Refrigerated with bottom and side copper serpentine tubing by means of high density and thickness ecologic injected insulation.
- Designed to place GN wells of up to 150mm deep (not included in the price).
- 1-metre-long mobile control panel with digital thermometer/thermostat and illuminated switch.
- Expansion system of coolant gas not included.



Bottom and side copper serpentine tubing



Model	Dimensions	Embedding dimensions	GN Capacity	Compressor (CV)*	RRP (€)
CF3G-6/R	1120x646x135	1095x625x120	3GN1/1-65	1/4	1.033
CF4G-6/R	1445x646x135	1420x625x120	4GN1/1-65	1/4	1.189
CF5G-6/R	1770x646x135	1745x625x120	5GN1/1-65	3/4	1.505
CF6G-6/R	2095x646x135	2070x625x120	6GN1/1-65	3/4	1.753
N CF1G-15/R	465x646x215	445x625x200	1GN1/1-150	1/5	924
CF2G-15/R	790x646x215	765x625x200	2GN1/1-150	1/5	1.010
CF3G-15/R	1120x646x215	1095x625x200	3GN1/1-150	1/4	1.091
CF4G-15/R	1445x646x215	1420x625x200	4GN1/1-150	1/4	1.262
CF5G-15/R	1770x646x215	1745x625x200	5GN1/1-150	3/4	1.545
CF6G-15/R	2095x646x215	2070x625x200	6GN1/1-150	3/4	1.790

* Compressor recommended for distances of up to 4 horizontal metres and coolant gas R-134a.

VENTILATED COOLED WELLS

- Manufactured of satin stainless steel AISI-304 18/10.
- Refrigeration by means of ventilated evaporator, gas R-290 and digital thermostat control. Optional gas R452A.
- High density and thickness ecologic injected insulation.
- Working interval temperature -4°C/+8°C.
- Height adjustable interior bottom, suitable for wells GN 65, 100 or 150mm deep.
- Built-in drainage.
- 1-metre-long mobile control panel with digital thermometer/thermostat and illuminated switch.
- Built-in condenser unit.
- Single-phase voltage 230v/50Hz.



Model	Dimensions	Embedding dimensions	GN Capacity	Consumption (W)	Refrig.Power (W)	RRP (€)
CFV2G/R	790x715x770	750x695x760	2GN1/1-150	670	800	1.780
CFV3G/R	1130x715x770	1080x695x760	3GN1/1-150	670	800	1.922
CFV4G/R	1455x715x770	1405x695x760	4GN1/1-150	1050	1445	2.178
CFV5G/R	1780x715x770	1730x695x760	5GN1/1-150	1050	1445	2.430

ICE CREAM WELLS WITH/WITHOUT REFRIGERATING UNIT

- Well with rounded sanitary edges.
- Refrigerated with bottom and side copper serpentine tubing by means of high density and thickness ecologic injected insulation. Coolant gas R-290.
- Optional gas R452A.
- 1-metre-long mobile control panel with digital thermometer/thermostat and illuminated switch.
- Working interval temperature -15°C/-20°C.
- Methacrylate sliding doors.
- Capacity for 4 ice-cream wells of 360x165x180mm of up to 7 litres (not included).
- Single-phase voltage 230v/50Hz.
- On CH4, expansion system of coolant gas not included.
- Regulation between -20°C and -14°C.



Model	Incorporated unit	Full dimensions	Embedding dimensions	Consumption (W)	Power W	RRP (€)
CH4	NO	810x540x280	785x455x270	1/3CV*	-	1.350
CH4-GI	SI	810x540x650	785x455x640	360	170	1.656

* Compressor recommended for distances up to 4 horizontal metres and coolant gas R-134a.

ICE CREAM WELLS

Model	Dimensions	Capacity	RRP (€)
GH-5	360x165x120	5 Litres	23,70
GH-7	360x165x150	7 Litres	28,70
GHT	360x165	Methacrylate lid	9,90



DISHERWASHER

- Manufactured of stainless steel AISI 304 18/10
- Inset cover for the washing of ice cream dishers.
- It integrates a water inlet in its lower part 3/8" and a water outlet 1/2".

Model	Dimensions	Embedding hole	RRP (€)
LP	110x270x145	255x95	75,70



CURVED GLASS SHOWCASES WITH VENTILATED COOLED WELL



- Manufactured of satin stainless steel AISI-304 18/10.
- Refrigerated by means of ventilated evaporator gas R-290 and digital thermostatic control. Optional gas R452A.
- High density and thickness ecologic injected insulation.
- Height adjustable interior bottom, suitable for wells GN 65, 100 or 150mm deep.
- Safety tempered glass.
- 3-level glass exhibit.
- 1-metre-long mobile control panel with digital thermometer/thermostat and illuminated switch.
- Built-in condenser unit.
- Single-phase voltage 230v/50Hz.

WALL SHOWCASES WITH VENTILATED COOLED WELL

- Back closed with stainless steel panels with double insulated wall.
- Front available in 2 finishes. Open with night shutter or methacrylate folding doors self-service style.



Model VMP4G Rolling shutter Model VMB4G Folding doors

Model	Front closing type	Dimensions	Embedding dimensions	GN Capacity	Consumption (W)	Refrig.Power (W)	RRP (€)
VMP3G/R	Rolling shutter	1130x715x1590	1080x695x760	3GN1/1-150	1100	1445	3.930
VMP4G/R	Rolling shutter	1455x715x1590	1405x695x760	4GN1/1-150	1100	1445	4.486
VMB3G/R	Folding doors	1130x715x1590	1080x695x760	3GN1/1-150	1100	1445	4.773
VMB4G/R	Folding doors	1455x715x1590	1405x695x760	4GN1/1-150	1100	1445	5.200

CENTRAL SHOWCASES WITH VENTILATED COOLED WELL

- Back part accessible by means of double glazing sliding doors.
- Front available in 3 finishes. Open with night shutter, folding doors self-service style or folding glass panel.



Model VCP4G Model VCB4G Model VCC4G

Model	Front closing type	Dimensions	Embedding dimensions	GN Capacity	Consumption (W)	Refrig.Power (W)	RRP (€)
VCP3G/R	Rolling shutter	1130x715x1590	1080x695x760	3GN1/1-150	1100	1445	4.103
VCP4G/R	Rolling shutter	1455x715x1590	1405x695x760	4GN1/1-150	1100	1445	4.558
VCB3G/R	Folding doors	1130x715x1590	1080x695x760	3GN1/1-150	1100	1445	4.798
VCB4G/R	Folding doors	1455x715x1590	1405x695x760	4GN1/1-150	1100	1445	5.338
VCC3G/R	Folding glass panel	1130x715x1590	1080x695x760	3GN1/1-150	1100	1445	4.195
VCC4G/R	Folding glass panel	1455x715x1590	1405x695x760	4GN1/1-150	1100	1445	4.745

NEW

STRAIGHT SHOWCASES WITH VENTILATED COOLED WELL



- Manufactured of satin stainless steel AISI-304 18/10.
- Refrigerated by means of ventilated evaporator gas R-290 and digital thermostatic control. Optional gas R452A.
- High density and thickness ecologic injected insulation.
- Height adjustable interior bottom, suitable for wells GN 65, 100 or 150mm deep.
- Safety tempered glass.
- 3-level glass exhibit.
- 1-metre-long mobile control panel with digital thermometer/thermostat and illuminated switch.
- Built-in condenser unit.
- Single-phase voltage 230v/50Hz.

STRAIGHT WALL SHOWCASES WITH VENTILATED COOLED WELL

- Back closed with stainless steel panels with double insulated wall.
- Front available in 2 finishes. Open with night shutter or methacrylate folding doors self-service style.



Model VRMP4G Rolling shutter Model VRMB4G Folding doors

Model	Front closing type	Dimensions	Embedding dimensions	GN Capacity	Consumption (W)	Refrig.Power (W)	RRP (€)
VRMP3G/R	Rolling shutter	1130x715x1590	1080x695x760	3GN1/1-150	1100	1445	3.930
VRMP4G/R	Rolling shutter	1455x715x1590	1405x695x760	4GN1/1-150	1100	1445	4.486
VRMB3G/R	Folding doors	1130x715x1590	1080x695x760	3GN1/1-150	1100	1445	4.773
VRMB4G/R	Folding doors	1455x715x1590	1405x695x760	4GN1/1-150	1100	1445	5.200

CENTRAL SHOWCASES WITH VENTILATED COOLED WELL

- Back part accessible by means of double glazing sliding doors.
- Front available in 3 finishes. Open with night shutter, folding doors self-service style or folding glass panel.



Model VRCP4G Model VRCB4G Model VRCC4G

Model	Front closing type	Dimensions	Embedding dimensions	GN Capacity	Consumption (W)	Refrig.Power (W)	RRP (€)
VRCP3G/R	Rolling shutter	1130x715x1590	1080x695x760	3GN1/1-150	1100	1445	4.103
VRCP4G/R	Rolling shutter	1455x715x1590	1405x695x760	4GN1/1-150	1100	1445	4.558
VRCB3G/R	Folding doors	1130x715x1590	1080x695x760	3GN1/1-150	1100	1445	4.798
VRCB4G/R	Folding doors	1455x715x1590	1405x695x760	4GN1/1-150	1100	1445	5.338
VRCC3G/R	Folding glass panel	1130x715x1590	1080x695x760	3GN1/1-150	1100	1445	4.195
VRCC4G/R	Folding glass panel	1455x715x1590	1405x695x760	4GN1/1-150	1100	1445	4.745

VENTILATED REFRIGERATED STRAIGHT SHOWCASES WITH INSULATED WELL



- Manufactured of satin stainless steel AISI-304 18/10.
- Refrigerated by means of ventilated evaporator gas R-290 y digital thermostatic control. Optional gas R452A.
- High density and thickness ecologic injected insulation.
- 3-level glass exhibit.
- Working interval temperature +4°C/+12°C.
- Entirely welded well with rounded sanitary edges and built-in drainage.
- Designed for wells GN of up to 150mm deep (not included).
- Double glazing sliding doors on the service side. Folding methacrylate doors on the clients side.
- Interior low- consumption lighting.
- Safety tempered glass.
- Mobile control panel with digital thermometer/ thermostat and illuminated switch.
- Built-in condenser unit.

Model	Dimensions	Embedding dimensions	GN Capacity	Consumption (W)	Refrig.Power (W)	Voltage	RRP (€)
VCF44G/R	1525x655x1500	1500x625x200	4GN1/1-150	1100	1445	230V/50Hz	4.354
VCF54G/R	1925x655x1500	1900x625x200	5GN1/1-150	1205	1750	230V/50Hz	5.528
VCF64G/R	2175x655x1500	2150x625x200	6GN1/1-150	1205	1750	230V/50Hz	6.697

VENTILATED REFRIGERATED SHOWCASES WITH INSULATED ON-MOTOR BASE



Model SVSM-160



Model SVSP-160

- Cooled showcase with insulated built-in base.
- They can be installed as an independent element on any straight surface.
- They are manufactured in two different types: open with roller shutter and closed with foldable doors.
- Manufactured of satin stainless steel AISI-304 18/10.
- Embedded interior base with rounded corners for a better hygiene and cleaning, built-in drainage.
- High density and thickness ecologic injected insulation.
- Refrigerated by means of ventilated evaporator gas R-290 and digital thermostatic control. Optional gas R452A,
- Working interval temperature +4°C/+12°C.
- Double glazing sliding doors on the service side and methacrylate folding doors on the clients´ side, except for the open model (SVSP-160) which includes a rolling shutter.
- Interior glass shelves, easily removable.
- Built-in condenser unit.
- Possibility of manufacture in 230V-1F/60Hz.
- Interior low- consumption lighting.

Model	Type	Dimensions	Power (W)	Refrig.Power (W)	Voltage	RRP (€)
SVSM-160/R	Folding doors	1525x655x1350	1100	1210	230V/50Hz	3.579
SVSM-200/R	Folding doors	1925x655x1350	1205	1650	230V/50Hz	3.994
SVSM-225/R	Folding doors	2175x655x1350	1205	1650	230V/50Hz	4.408
SVSP-160/R	rolling shutter	1525x655x1350	1205	1650	230V/50Hz	4.346

HUMID HEATED BAIN-MARIE WELL

- Manufactured of satin stainless steel AISI-304 18/10.
- Wells with rounded sanitary edges and drainage.
- Designed for GN wells of up to 150mm deep.
- Fire-resistant polyurethane insulation.
- Well heating by silicone resistances with security klixon.
- 1-metre-long mobile control panel with digital thermometer/thermostat and illuminated switch. It contains a remova-

- ble panel that can be placed on the exterior part of the equipment to facilitate the temperature view and the equipment control.
- Adjustable working temperature+50°C/+90°C.
- Water intake tap of 1/2" and drainage with overflow pipe and outlet of 3/4".



GN trays not included

Model	Dimensions	Embedding dimensions	GN Capacity	Power (W)	Voltage	RRP (€)
N CCH1G	465x646x215	435x625x200	1GN1/1-150	1000	230V/50-60Hz	996
CCH2G	790x646x215	765x625x200	2GN1/1-150	1000	230V/50-60Hz	1.106
CCH3G	1120x646x215	1095x625x200	3GN1/1-150	2000	230V/50-60Hz	1.355
CCH4G	1445x646x215	1420x625x200	4GN1/1-150	3000	230V/50-60Hz	1.487
CCH5G	1770x646x215	1745x625x200	5GN1/1-150	3000	230V/50-60Hz	1.765
CCH6G	2095x646x215	2070x625x200	6GN1/1-150	4000	400V/III/50-60Hz	2.150

DRY HEATED BAIN-MARIE WELLS

- Manufactured of satin stainless steel AISI-304 18/10.
- Designed for GN wells of up to 100mm deep (not Included).
- Shielded resistances heating protected by means of drilled double bottom with safety klixon.
- Folding resistances to facilitate its cleaning.
- 1-metre-long mobile control panel with digital thermometer/

- thermostat and illuminated switch. It contains a removable panel that can be placed on the exterior part of the module to facilitate the temperature view and the equipment control.
- Adjustable working temperature+50°C/+90°C.
- Single-phase voltage 230V/50Hz



Model	Dimensions	Embedding dimensions	GN Capacity	Power (W)	Voltage	RRP (€)
CCS2G	790x646x215	765x625x200	2GN1/1-100	1200	230V/50-60Hz	892
CCS3G	1120x646x215	1095x625x200	3GN1/1-100	1750	230V/50-60Hz	960
CCS4G	1445x646x215	1420x625x200	4GN1/1-100	2500	230V/50-60Hz	1.133
CCS5G	1770x646x215	1745x625x200	5GN1/1-100	2950	230V/50-60Hz	1.416
CCS6G	2095x646x215	2070x625x200	6GN1/1-100	3500	230V/50-60Hz	1.747

GLASS-CERAMIC HOT PLATE

- Manufactured of satin stainless steel AISI-304 18/10.
- SCHOTT CERAN® glass-ceramic, 6mm thick.
- Well heating by silicone electric resistances with security klixon.
- Fire-resistant polyurethane insulation.
- Working temperature 50°C to 100°C regulated by means of electronic thermostat.
- Sealed perimeter by means of special black silicone.
- 1-metre-long mobile control panel with digital thermometer/thermostat and illuminated switch.



Model	GN Capacity	Dimensions	Embedding dimensions	Power (W)	Voltage	RRP (€)
PCV2G	2GN1/1	790x646x135	765x625x120	1100	230V/50-60Hz	1.316
PCV3G	3GN1/1	1120x646x135	1095x625x120	1650	230V/50-60Hz	1.569
PCV4G	4GN1/1	1445x646x135	1420x625x120	2200	230V/50-60Hz	1.785
PCV5G	5GN1/1	1770x646x135	1745x625x120	2750	230V/50-60Hz	2.035
PCV6G	6GN1/1	2095x646x135	2070x625x120	3300	230V/50-60Hz	2.336

TEMPERED GLASS HOT PLATE GN

NEW

- Manufactured of satin stainless steel AISI-304 18/10.
- Black or white tempered glass, 6mm thick.
- Well heating by silicone electric resistances with security klixon.
- Fire-resistant polyurethane insulation.
- Working temperature 50°C to 100°C regulated by means of electronic thermostat.
- Sealed perimeter by means of special black silicone.
- 1-metre-long mobile control panel with digital thermometer/thermostat and illuminated switch.



GN Capacity	Dimensions	Embedding dimensions	Power (W)	Voltage	WHITE		BLACK	
					Model	RRP (€)	Model	RRP (€)
2GN1/1	790x646x135	765x625x120	1100	230V/50-60Hz	PCT2GB	1.058	PCT2GN	1.058
3GN1/1	1120x646x135	1095x625x120	1650	230V/50-60Hz	PCT3GB	1.277	PCT3GN	1.277
4GN1/1	1445x646x135	1420x625x120	2200	230V/50-60Hz	PCT4GB	1.470	PCT4GN	1.470
5GN1/1	1770x646x135	1745x625x120	2750	230V/50-60Hz	PCT5GB	1.696	PCT5GN	1.696
6GN1/1	2095x646x135	2070x625x120	3300	230V/50-60Hz	PCT6GB	1.969	PCT6GN	1.969

GLASS-CERAMIC HOT PLATE (SHOW COOKING)

NEW

- Manufactured of satin stainless steel AISI-304 18/10.
- SCHOTT CERAN® glass-ceramic, 6mm thick.
- Well heating by silicone electric resistances with security klixon.
- These hot plates do not accept the installation of Drop-in units.
- Working temperature 50°C to 100°C regulated by means of electronic thermostat.
- Sealed perimeter by means of special black silicone.
- 1-metre-long mobile control panel with digital thermometer/thermostat and illuminated switch.



Model	Capacity of plates Ø26cm	Dimensions	Embedding dimensions	Power (W)	Voltage	RRP (€)
PCV3P	3	866x326x135	840x300x120	700	230V/50-60Hz	1.145
PCV5P	5	1366x326x135	1340x300x120	1050	230V/50-60Hz	1.674
PCV6P	6	1668x326x135	1645x300x121	1400	230V/50-60Hz	1.921
PCV8P	8	2168x326x135	2145x300x121	1750	230V/50-60Hz	2.197

HEATED TEMPERED GLASS HOT PLATE (SHOW COOKING)

NEW

- Manufactured of satin stainless steel AISI-304 18/10.
- Black or white tempered glass 6mm thick.
- Well heating by silicone electric resistances with security klixon.
- Fire-resistant polyurethane insulation.
- These hot plates do not accept the installation of Drop-in units.
- Working temperature 50°C to 100°C regulated by means of electronic thermostat.
- Sealed perimeter by means of special black silicone.
- 1-metre-long mobile control panel with digital thermometer/thermostat and illuminated switch



Capacity of plates Ø26cm	Dimensions	Embedding dimensions	Power (W)	Voltage	WHITE		BLACK	
					Model	RRP (€)	Model	RRP (€)
3	866x326x135	840x300x120	700	230V/50-60Hz	PCT3PB	921	PCT3PN	921
5	1366x326x135	1340x300x120	1050	230V/50-60Hz	PCT5PB	1.362	PCT5PN	1.362
6	1668x326x135	1645x300x120	1400	230V/50-60Hz	PCT6PB	1.582	PCT6PN	1.582
8	2168x326x135	2145x300x120	1750	230V/50-60Hz	PCT8PB	1.831	PCT8PN	1.831

TEMPERED GLASS TABLETOP HOT PLATE

NEW

- Manufactured of satin stainless steel AISI-304 18/10.
- Well heating by silicone electric resistances with security klaxon.
- Temperature regulation by means of thermostat of 50°C to 100°C and illuminated switch.
- Tempered glass, 6mm thick.



PCV-5050



PCV-6454



PCV-10050

Model	Total Measurements	Glass Measurements	Power (W)	Voltage	RRP (€)
PCV-5050	500x500x80	500x500	400	230V/50-60Hz	459
PCV-6454	640x540x80	640x540	800	230V/50-60Hz	557
PCV-10050	1000x500x80	1000x500	800	230V/50-60Hz	650

WARMING UNIT

NEW

- The heat strip together with the hot plate makes an ideal kit for the maintenance of food that needs heat on the lower and upper parts.
- Manufactured of satin stainless steel AISI-304 18/10.
- Heating and lighting by ceramic resistance and halogen bulbs.

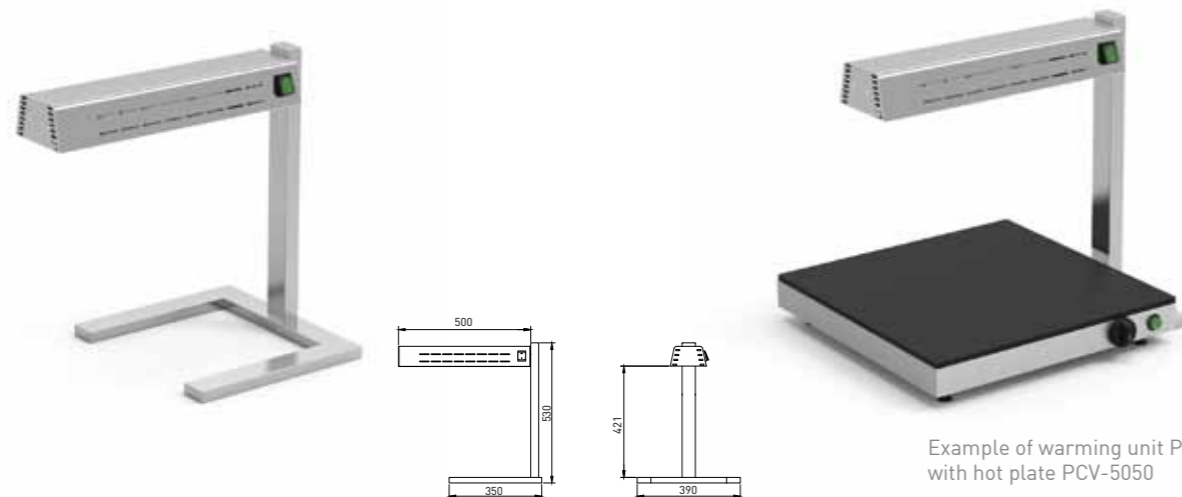

Example of warming unit PMC with hot plate PCV-5050

Model	Dimensions	Power (W)	Voltage	RRP (€)
PMC	532x392x530	330	230V/50-60Hz	552

DROP-IN AND BUFFET UNITS BRACKETS KIT

The ample variety of brackets, units and glass panels enables our clients to find an adequate solution to each necessity and/or setting.

- **2 types of installation systems**
 - Directly on the equipment, on the stainless steel frame (Drop-in).
 - Exterior, directly on the counter top (Buffet).
- **3 different types of brackets**
 - On rounded tube Ø50mm.
 - On rectangular vertical tube 60x40 mm.
 - On tilted rectangular tube 60x40mm.
- **2 types of lighting and heat**
 - Models with LED lighting.
 - Models with lighting and heat.
- **3 types of tempered glass**
 - Double curve glass.
 - Straight glass.
 - Front glass.

DROP-IN MODELS /INTERIOR

The bracket is placed on the lateral frames of the Drop-in elements. It is easily installed due to the fact that the inferior part of all devices shows an indication of the place where to drill for a perfect joint.



Example of rounded bracket, Drop-in and curved glass



Example of rectangular tilted bracket, Drop-in and straight glass

BUFFET MODELS /EXTERIOR

In this case the bracket is placed directly on the surface of the Buffet, easily installed by means of the included support.

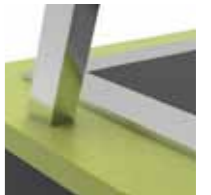

Example of tilted rectangular Buffet bracket and straight glass



Example of rectangular vertical Buffet bracket and straight glass

BRACKETS AND LAMP STRIP UNITS

NEW DESIGN

- Each type of bracket contains the correspondent lamp strip or lamp strip with heat.
- Manufactured of satin stainless steel AISI-304 18/10 easy to install.
- Tempered glass, 6mm thick.
- Straight or curved safety tempered glass (Important: not included with lamp strips, separate order needed).
- 2 types of strips
 - Models with LED lighting.
 - Models with heat and light, they include heating by means of ceramic resistances and halogen lighting.
- Electric connection 230V/50-60Hz



Unit with LED lighting



Unit with halogen lighting and ceramic heating

BRACKETS WITH DROP-IN LAMP STRIP

ROUNDED TUBE BRACKETS (DROP-IN) WITH LAMP STRIP



Example of rounded bracket with curved glass*

Example of rounded bracket with curved glass and front glass protector*

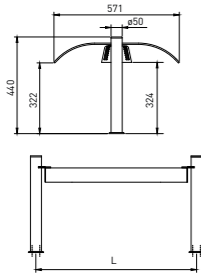

Cap.	Dimensions	L	LAMP STRIP			HEAT LAMP STRIP		
			Model	Power (W)	RRP (€)	Model	Power (W)	RRP (€)
2GN	788x136x440	720	PL-2GN	8	515	PLC-2GN	580	589
3GN	1118x136x440	1050	PL-3GN	16	540	PLC-3GN	910	617
4GN	1443x136x440	1375	PL-4GN	24	577	PLC-4GN	1240	668
5GN	1768x136x440	1700	PL-5GN	32	609	PLC-5GN	1570	748
6GN	2093x136x440	2025	PL-6GN	32	654	PLC-6GN	1900	835

NEW

VERTICAL RECTANGULAR TUBE BRACKETS (DROP-IN) WITH LAMP STRIP



Example of rectangular bracket with straight glass*

Example of rectangular bracket with curved glass*

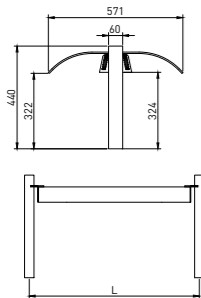

Cap.	Dimensions	L	LAMP STRIP			HEAT LAMP STRIP		
			Model	Power (W)	RRP (€)	Model	Power (W)	RRP (€)
2GN	762x136x440	720	PLR-2GN	8	515	PLCR-2GN	580	589
3GN	1092x136x440	1050	PLR-3GN	16	540	PLCR-3GN	910	617
4GN	1417x136x440	1375	PLR-4GN	24	577	PLCR-4GN	1240	668
5GN	1742x136x440	1700	PLR-5GN	32	609	PLCR-5GN	1570	748
6GN	2067x136x440	2025	PLR-6GN	32	654	PLCR-6GN	1900	835

NEW

TILTED RECTANGULAR TUBE BRACKETS (DROP-IN) WITH LAMP STRIP



Example of tilted rectangular bracket with straight glass*

Example of tilted rectangular bracket with straight glass and front glass protector*

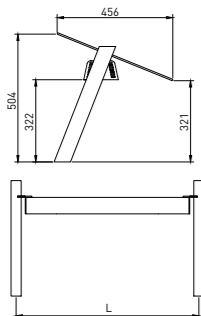

Cap.	Dimensions	L	LAMP STRIP			HEAT LAMP STRIP		
			Model	Power (W)	RRP (€)	Model	Power (W)	RRP (€)
2GN	762x245x440	720	PLI-2GN	8	601	PLCI-2GN	580	675
3GN	1092x245x440	1050	PLI-3GN	16	627	PLCI-3GN	910	703
4GN	1417x245x440	1375	PLI-4GN	24	663	PLCI-4GN	1240	754
5GN	1742x245x440	1700	PLI-5GN	32	695	PLCI-5GN	1570	834
6GN	2067x245x440	2025	PLI-6GN	32	741	PLCI-6GN	1900	921

* Glass and Drop-in elements not included in the price.

BRACKETS WITH BUFFET LAMP STRIP

ROUNDED TUBE BRACKETS (BUFFET) WITH LAMP STRIP



Example of rounded bracket with curved glass*

Example of rounded bracket with straight glass*

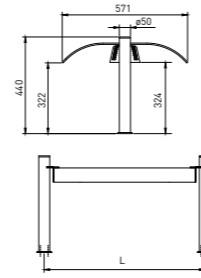

Cap.	Dimensions	L	LAMP STRIP			HEAT LAMP STRIP		
			Model	Power (W)	RRP (€)	Model	Power (W)	RRP (€)
2GN	984x136x440	917	BPL-2GN	8	536	BPLC-2GN	580	650
3GN	1314x136x440	1247	BPL-3GN	16	561	BPLC-3GN	910	678
4GN	1639x136x440	1572	BPL-4GN	24	598	BPLC-4GN	1240	729
5GN	1964x136x440	1897	BPL-5GN	32	630	BPLC-5GN	1570	809
6GN	2289x136x440	2222	BPL-6GN	32	675	BPLC-6GN	1900	896

NEW

RECTANGULAR VERTICAL TUBE BRACKETS (BUFFET) WITH LAMP STRIP



Example of straight bracket with straight glass*

Example of straight bracket with curved glass*

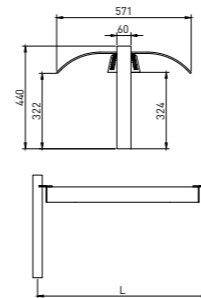

Cap.	Dimensions	L	LAMP STRIP			HEAT LAMP STRIP		
			Model	Power (W)	RRP (€)	Model	Power (W)	RRP (€)
2GN	958x136x440	917	BPLR-2GN	8	536	BPLCR-2GN	580	650
3GN	1288x136x440	1247	BPLR-3GN	16	561	BPLCR-3GN	910	678
4GN	1613x136x440	1572	BPLR-4GN	24	598	BPLCR-4GN	1240	729
5GN	1938x136x440	1897	BPLR-5GN	32	630	BPLCR-5GN	1570	809
6GN	2263x136x440	2222	BPLR-6GN	32	675	BPLCR-6GN	1900	896

NEW

RECTANGULAR TILTED TUBE BRACKETS (BUFFET) WITH LAMP STRIP



Example of straight bracket with straight glass*

Example of straight bracket with straight glass*

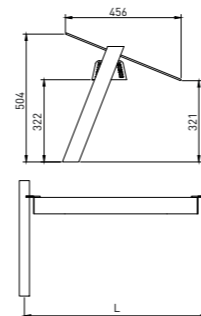

Cap.	Dimensions	L	LAMP STRIP			HEAT LAMP STRIP		
			Model	Power (W)	RRP (€)	Model	Power (W)	RRP (€)
2GN	958x245x440	917	BPLI-2GN	8	622	BPLCI-2GN	580	713
3GN	1288x245x440	1247	BPLI-3GN	16	648	BPLCI-3GN	910	741
4GN	1613x245x440	1572	BPLI-4GN	24	684	BPLCI-4GN	1240	792
5GN	1938x245x440	1897	BPLI-5GN	32	716	BPLCI-5GN	1570	872
6GN	2263x245x440	2222	BPLI-6GN	32	762	BPLCI-6GN	1900	959

* Glass and Drop-in elements not included in the price.

CURVED DROP-IN GLASS



Model	Dimensions	RRP (€)
CR-2GN	647x570x90	245
CR-3GN	977x570x90	288
CR-4GN	1302x570x90	311
CR-5GN	1627x570x90	328
CR-6GN	1952x570x90	350

STRAIGHT DROP-IN GLASS PANELS
STRAIGHT OR TILTED BRACKETS

Model	Dimensions	RRP (€)
CRR-2GN	647x540x6	95
CRR-3GN	977x540x6	107
CRR-4GN	1302x540x6	126
CRR-5GN	1627x540x6	158
CRR-6GN	1952x540x6	189

SNEEZEGUARD DROP-IN GLASS



Model	Dimensions	RRP (€)
DCRV-2GN	647x90x6	73
DCRV-3GN	977x90x6	81
DCRV-4GN	1302x90x6	93
DCRV-5GN	1627x90x6	114
DCRV-6GN	1952x90x6	135

DROP-IN HARDWARE FRONT GLASS PANEL KIT



Model	For glass fitting	N° of 2 pieces kit	RRP (€)
KHV-2	2/3/4GN	2	84
KHV-3	5/6GN	3	126

DIGITAL THERMOMETRE KIT

- It enables to show the clients the temperature of the Drop-in element situated in the lower part: cold plate base/well or hot plate base/well.

Model	Suitable for	Dimensions	RRP (€)
KTD-F	Cooled Drop-in	102x132x42	60
KTD-C	Heated Drop-in	102x132x42	60



CURVED BUFFET GLASS



Model	Dimensions	RRP (€)
BCR-2GN	843x570x90	257
BCR-3GN	1173x570x90	300
BCR-4GN	1498x570x90	323
BCR-5GN	1823x570x90	340
BCR-6GN	2148x570x90	362

STRAIGHT BUFFET GLASS PANELS
STRAIGHT OR TILTED BRACKETS

Model	Dimensions	RRP (€)
BCRR-2GN	843x540x6	109
BCRR-3GN	1173x540x6	121
BCRR-4GN	1498x540x6	140
BCRR-5GN	1823x540x6	172
BCRR-6GN	2148x540x6	203

SNEEZEGUARD BUFFET GLASS



Model	Dimensions	RRP (€)
BCRV-2GN	843x90x6	73
BCRV-3GN	1173x90x6	81
BCRV-4GN	1498x90x6	93
BCRV-5GN	1823x90x6	114
BCRV-6GN	2148x90x6	135

NEUTRAL DROP-IN BRACKETS

- Manufactured of satin stainless steel AISI-304 18/10 easy to install.
- 2 brackets will be delivered with each model.
- From model 4GN, inclusive, a reinforcement which joins the brackets will be included.



RECTANGULAR TUBE 60x40mm

For modules	Dimensions	DROP-IN		BUFFET	
		Model	RRP (€)	Model	RRP (€)
2/3GN	60x40x440	SSR	226	SSR	226
4GN	60x40x440	SSR4	268	BSSR4	270
5GN	60x40x440	SSR5	271	BSSR5	273
6GN	60x40x440	SSR6	273	BSSR6	275

BREAD, CUTLERY AND GLASSES DISPENSERS

- Manufactured of satin stainless steel AISI-304 18/10 easy to install.
- Rounded tube legs, Ø 50mm.
- Two possible clamping systems: Adjustable legs or bolted onto countertop (both included).
- In the model SDPS, the upper tray includes holes for 1 well GN 1/1 and 4 wells GN 1/4 (wells are not included; see stainless steel wells kit KCDP).



Model SDPS

Model SDVS

Model	Type of dispenser	Dimensions	RRP (€)
SDPS	Bread, cutlery and glasses	715x690x665	636
SDVS	Glasses	715x690x665	762
KCDP	Cover Kit GN	1 GN 1/1 100 4 GN 1/4 100	107,5



SDPS + KCDP

EMBEDDING PLATES DISPENSERS

- Manufactured of satin stainless steel AISI-304 18/10 easy to install.
- Suitable for plates of Ø 210 to 278mm.
- Plates stay at countertop level by means of adjustable spring system.
- The heated models included illuminated switch and adjustable electronic resistance by analogue thermostat.
- Optional plastic lid for an improved thermal insulation.



Model	Type	Approx. N° of plates	Power (W)	Dimensions	Embedding hole	RRP (€)
DPN-45	Neutral	45	-	ø368x643	ø358	440
DPN-60	Neutral	60	-	ø368x748	ø358	498
DPC-45	Hot	45	500	ø368x656	ø358	918
DPC-60	Hot	60	500	ø368x761	ø358	988
TDP	Lid	-	-	ø365x80	-	58



Maximum quality
High quality Buffet module manufactured on a very robust structure constructed with materials of leading brands, carefully selected and handled.



Customization and decoration
The possibilities of functionally and aesthetically personalizing these products are vast. This enables the characteristics of buffet module to be easily adapted to the necessities of each client.

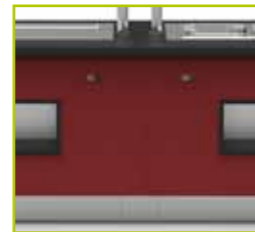

Modularity and functionality
Buffet modules can be supplied independently or in lineal module of big sizes, thanks to such options as the union kit. Configuration possibilities are enormous.



Easy installation
The modules are supplied fully assembled and they have solid wheels. The laterals and plinths are removable for an easy access to their interior.



Finish and design
The details and aesthetics have been thoroughly supervised. Countertops as well as decorative panels are manufactured in one piece without joints or unions.

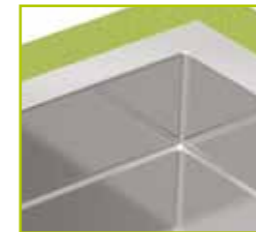

Hygiene and ergonomics
The modular buffet has been designed considering its functional ergonomics from the point of view of the user thus it is user-friendly and enables easy maintenance and cleanness.



Broad range and availability
The variety of modules is wide and together with the drop-in elements it offers ample setting possibilities. It also has short-term manufacturing periods.



Show-cooking modules
The show-cooking series enlarges the possibilities of Eratos buffet settings. It can be equipped with hot plate and be accompanied by an induction show-cooking extractor hood.



BUFFET MODULE FOR DROP-IN

- Available in 4 lengths, for maximum capacities of 3, 4, 5 and 6 GN1/1 and with two different depths 85 and 110cm.
- One piece synthetic quartz counter top without joints.
- Countertop with enlarged edges to 6cm.
- Waterproof lacquered decorative front panels or, optionally, manufactured of waterproof wood with melamine finish.
- Reinforced metallic structure.
- Height adjustable legs for a correct levelling.
- All models contain stainless steel AISI 304 18/10 perimeter plinth, easily removable.
- Equipped with wheels for easy mobility and installation.
- Easily removable laterals for an easy access to the interior of the buffet, with ventilation grille.
- Possibility of joining buffets by means of a joint kit, making it

possible to create lineal Buffet modules of any composition and length.

- Any drop-in element can be embedded (ventilated refrigerated Drop-in cannot be embedded in Buffet modules with plates shelves).
- Lamp strip and heat lamp strip available for each model, being also possible to embed Drop-in elements with their own installed lamp strips.
- Optional shelves for plates, manufactured of the same material as the countertop.
- LED lighting is added on the plates shelves.

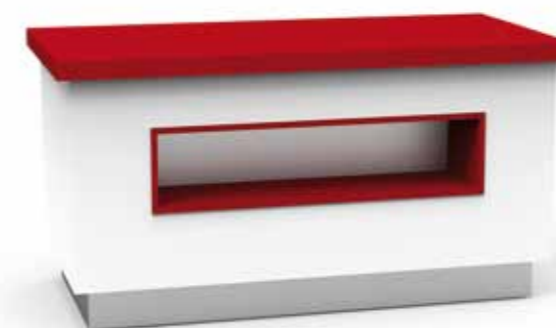

SETTING OF BUFFET IN PICTURE

- Module MBP8-4G/0.
- Countertop decoration, option BDCE8-4GN RED.
- Front panels decoration WHITE RAL-9003 standard.



SETTING OF THIS BUFFET IN PICTURE:

- Module BDP11-5G/5.
- Countertop decoration, option BDCE11-5GN BLACK.
- Plates shelf decoration, option BCE11-5GN BLACK.
- Front panels decoration, option BDCD11-5GN OAK.
- Drop-in PCV5G.
- Buffet-style lamp strip BPLC-5GN.
- Buffet-style glass BCR-5GN.

INSTRUCTIONS FOR BUFFET SETTING

1. To select the **depth** of the buffett:
 - 85cm: Compact buffet for central or wall setting, go to page 168.
 - 110 cm: Central wide buffet, go to page 169.
2. To select the **length (maximum GN capacity)**, the optional shelves for plates and the distribution of shafts for the embedment of Drop-in elements:
 - 3G/N1/1: Length 1375mm, with maximum capacity for a Drop-in of well 3GN1/1.
 - 4G/N1/1: Length 1700mm, with maximum capacity for a Drop-in of well 4GN1/1.
 - 5G/N1/1: Length 2025mm, with maximum capacity for a Drop-in of well 5GN1/1.
 - 6G/N1/1: Length 2350mm, with maximum capacity for a Drop-in of well 6GN1/1.
 - Note 1: The ventilated cooled wells, showcases, ice cream wells and dry bain-marie cannot be embedded on modules with plates shelves.
 - Note 2: The Drop-in ice cream well requires a size of 2GN1/1.
3. To select the **decoration** of the buffet:
 - Countertop (and plates shelves) decoration: WHITE is standard finish included in the price. For other available options, go to page 172.
 - Front panels decoration: Select a standard front decoration (go to page 173) or request a customized decoration.
4. To select the **Drop-in elements** to embed in the shafts, go to pages 148-157.
5. To select the **lamp strips and glass panels** suitable for buffet 2, 3, 4, 5 or 6GN, go to pages 159.163.
 - There is a great variety of brackets, lamp strips and glass panels, with 2 possibilities of placement, one onto the SST frame of the Drop-in section (Model DROP-IN) and the other directly onto the countertop of the Buffet (Model BUFFET).
6. **Additional options**, go to page 172-173:
 - Backsplash options: it enables the wall setting of 86mm deep Buffets.
 - For the creation of a lineal Buffet by means of the joint of 2 or more modules, select "Option joint kit" (BKU) and set the module.

ERATOS CATALOG 2020

BUFFET MODULE FOR DROP-IN 85 DEEP



3GN module with a plate shelf, no shaft on countertop, model BDP8-3G/0



Module without plates shelves with shaft for 5GN, model BD8-5G/5

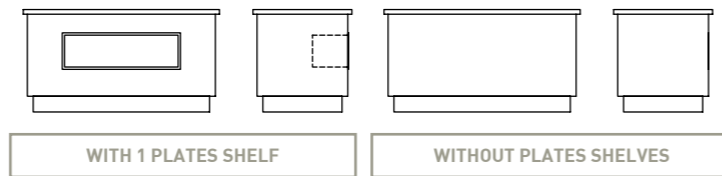

Max capacity	Dimensions	Embedding shafts Drop-in	Model	RRP (€)	Model	RRP (€)
NEW 3 GN1/1	1375x850x900	1 of 3GN	BDP8-3G/3	2.179	BD8-3G/3	1.902
	1375x850x900	1 of 2GN (left)	BDP8-3G/20	2.179	BD8-3G/20	1.902
	1375x850x900	1 of 2GN (right)	BDP8-3G/02	2.179	BD8-3G/02	1.902
	1375x850x900	Without shaft- Neutral Buffet	BDP8-3G/0	2.179	BD8-3G/0	1.902
4 GN1/1	1700x850x900	1 of 4GN	BDP8-4G/4	2.458	BD8-4G/4	2.113
	1700x850x900	1 of 3GN (left)	BDP8-4G/30	2.458	BD8-4G/30	2.113
	1700x850x900	1 of 3GN (right)	BDP8-4G/03	2.458	BD8-4G/03	2.113
	1700x850x900	1 of 2GN (left)	BDP8-4G/20	2.458	BD8-4G/20	2.113
	1700x850x900	1 of 2GN (right)	BDP8-4G/02	2.458	BD8-4G/02	2.113
	1700x850x900	Without shaft- Neutral Buffet	BDP8-4G/0	2.458	BD8-4G/0	2.113
	5 GN1/1	2025x850x900	1 of 5GN	BDP8-5G/5	2.763	BD8-5G/5
2025x850x900		1 of 4GN (left)	BDP8-5G/40	2.763	BD8-5G/40	2.358
2025x850x900		1 of 4GN (right)	BDP8-5G/04	2.763	BD8-5G/04	2.358
2025x850x900		1 of 3GN (left)	BDP8-5G/30	2.763	BD8-5G/30	2.358
2025x850x900		1 of 3GN (right)	BDP8-5G/03	2.763	BD8-5G/03	2.358
2025x850x900		1 of 2GN (left)	BDP8-5G/20	2.763	BD8-5G/20	2.358
2025x850x900		1 of 2GN (right)	BDP8-5G/02	2.763	BD8-5G/02	2.358
2025x850x900		2 of 2GN	BDP8-5G/22	2.763	BD8-5G/22	2.358
2025x850x900		Without shaft- Neutral Buffet	BDP8-5G/0	2.763	BD8-5G/0	2.358
6 GN1/1	2350x850x900	1 of 6GN	BDP8-6G/6	3.026	BD8-6G/6	2.570
	2350x850x900	1 of 5GN (left)	BDP8-6G/50	3.026	BD8-6G/50	2.570
	2350x850x900	1 of 5GN (right)	BDP8-6G/05	3.026	BD8-6G/05	2.570
	2350x850x900	1 of 4GN (left)	BDP8-6G/40	3.026	BD8-6G/40	2.570
	2350x850x900	1 of 4GN (right)	BDP8-6G/04	3.026	BD8-6G/04	2.570
	2350x850x900	1 of 3GN (left)	BDP8-6G/30	3.026	BD8-6G/30	2.570
	2350x850x900	1 of 3GN (right)	BDP8-6G/03	3.026	BD8-6G/03	2.570
	2350x850x900	1 of 3GN + 1 of 2GN	BDP8-6G/32	3.026	BD8-6G/32	2.570
	2350x850x900	1 of 2GN + 1 of 3GN	BDP8-6G/23	3.026	BD8-6G/23	2.570
	2350x850x900	1 of 2GN (left)	BDP8-6G/20	3.026	BD8-6G/20	2.570
	2350x850x900	1 of 2GN (right)	BDP8-6G/02	3.026	BD8-6G/02	2.570
	2350x850x900	2 of 2GN	BDP8-6G/22	3.026	BD8-6G/22	2.570
	2350x850x900	Without shaft- Neutral Buffet	BDP8-6G/0	3.026	BD8-6G/0	2.570

BUFFET MODULE FOR DROP-IN 110 DEEP



3GN module without plate shelves, no shaft on countertop, model BD11-3G/0



6GN module with 2 plates shelves and 2 shafts on the countertop, one for the embedment of 1 Drop-in well 2GN, and the other for 1 Drop-in well 3GN, model BDP11-6G/32

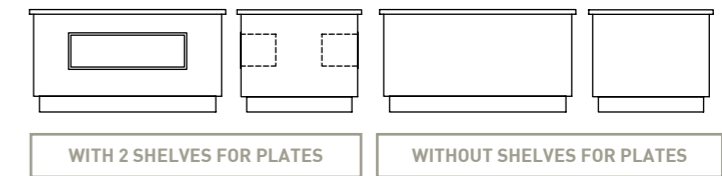

Max capacity	Dimensions	Embedding shafts Drop-in	Model	RRP (€)	Model	RRP (€)	
NEW 3 GN1/1	1375x1100x900	1 of 3GN	BDP11-3G/3	2.711	BD11-3G/3	2.156	
	1375x1100x900	1 of 2GN	BDP11-3G/2	2.711	BD11-3G/2	2.156	
	1375x1100x900	Without shaft- Neutral Buffet	BDP11-3G/0	2.711	BD11-3G/0	2.156	
4 GN1/1	1700x1100x900	1 of 4GN	BDP11-4G/4	3.134	BD11-4G/4	2.443	
	1700x1100x900	1 of 3GN	BDP11-4G/3	3.134	BD11-4G/3	2.443	
	1700x1100x900	1 of 2GN	BDP11-4G/2	3.134	BD11-4G/2	2.443	
	1700x1100x900	Without shaft- Neutral Buffet	BDP11-4G/0	3.134	BD11-4G/0	2.443	
	1700x1100x900	Without shaft- Neutral Buffet	BDP11-4G/0	3.134	BD11-4G/0	2.443	
5 GN1/1	2025x1100x900	1 of 5GN	BDP11-5G/5	3.541	BD11-5G/5	2.731	
	2025x1100x900	1 of 4GN	BDP11-5G/4	3.541	BD11-5G/4	2.731	
	2025x1100x900	1 of 3GN	BDP11-5G/3	3.541	BD11-5G/3	2.731	
	2025x1100x900	1 of 2GN	BDP11-5G/2	3.541	BD11-5G/2	2.731	
	2025x1100x900	2 of 2GN	BDP11-5G/22	3.541	BD11-5G/22	2.731	
	2025x1100x900	Without shaft- Neutral Buffet	BDP11-5G/0	3.541	BD11-5G/0	2.731	
	6 GN1/1	2350x1100x900	1 of 6GN	BDP11-6G/6	3.900	BD11-6G/6	2.990
		2350x1100x900	1 of 5GN	BDP11-6G/5	3.900	BD11-6G/5	2.990
2350x1100x900		1 of 4GN	BDP11-6G/4	3.900	BD11-6G/4	2.990	
2350x1100x900		1 of 3GN	BDP11-6G/3	3.900	BD11-6G/3	2.990	
2350x1100x900		1 of 3GN + 1 of 2GN	BDP11-6G/32	3.900	BD11-6G/32	2.990	
2350x1100x900		1 of 2GN	BDP11-6G/2	3.900	BD11-6G/2	2.990	
2350x1100x900		2 of 2GN	BDP11-6G/22	3.900	BD11-6G/22	2.990	
2350x1100x900		Without shaft- Neutral Buffet	BDP11-6G/0	3.900	BD11-6G/0	2.990	

BUFFET MODULE FOR SHOW COOKING

NEW



- Available in 2 lengths (2025 and 2350mm), and 2 depths (1100 and 1250mm).
- There are models with the possibility of adding tempered or vitro-ceramic glass for temperature maintenance on the front part of the countertop.
- Reinforced metal structure.
- Quartz synthetic countertop, manufactured in one piece and without joints.
- Countertop with enlarged edges to 6cm.
- Waterproof lacquered decorative front and lateral panels or, optionally, manufactured of waterproof wood with melamine finish, see page 173.
- Stainless steel AISI 304 18/10 front on the side of the cook.
- Height adjustable legs for a correct levelling.
- Equipped with wheels for easy mobility and installation.
- Easily removable laterals for an easy access to the interior of the buffet.
- All models contain stainless steel AISI 304 18/10 perimeter plinth, easily removable.
- Possibility of joining Buffets by means of the joint kit, making it possible to create lineal Buffet modules of any composition and length.
- The rear part of the sockets is free for the cooking equipment installation.

INSTRUCTIONS FOR SHOW COOKING SETTING

- 1. Selection of the depth of the show cooking equipment:**
 - 110cm: Compact show-cooking for 60 or 75cm deep cooking elements. It can be combined with Buffet models 85 or 110cm deep.
 - 125cm: Show-cooking for 75cm deep cooking elements. It can be combined with buffet models 85 or 110cm deep.
- 2. Selection of the length, the optional hot plate shaft and the size of recess for cooking elements.**
 - 5G/N1/1: Length 2025mm, with a recess for cooking elements of 1600mm long.
 - 6G/N1/1: Length 2350mm, with a recess for cooking elements of 1800mm long.
- 3. Selection of the decoration of the show-cooking:**
 - Countertop decoration: WHITE is standard finish included in the price. For other available options, go to page 172.
 - Front panels decoration: Select a standard front decoration (go to page 173) or request a customized decoration.
- 4. Additional options:**
 - If show-cooking with shaft for hot plate has been selected, the type of colour of this plate has to be selected as well.
 - For the creation of a lineal Buffet by means of the joint of 2 or more modules, select "Option joint kit" (BKU) and set the module, see page 173.

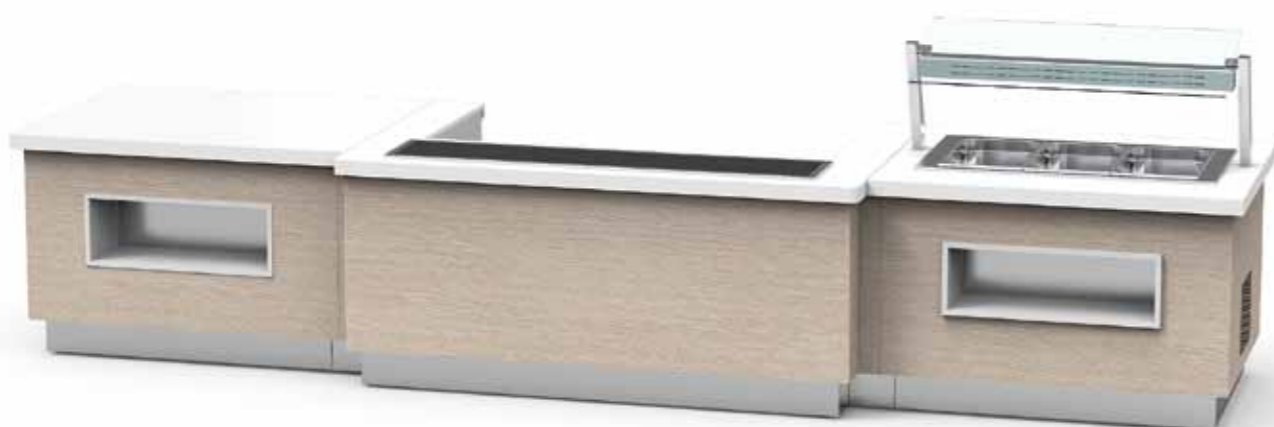

SHOW COOKING MODULE 110 DEEP

NEW

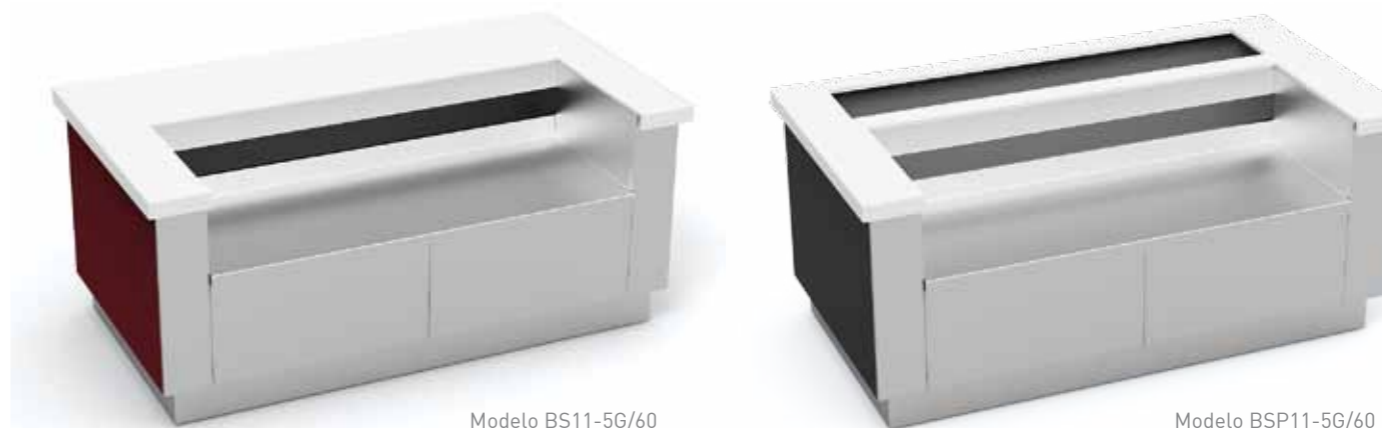

Length	Model	Dimensions	Hot plate shaft	Recess for cooking equipment	RRP (€)
2025	BS11-5G/60	2025x1100x900	NO	1600x600	2753
	BSP11-5G/60	2025x1100x900	1645x300	1600x600	2787
	BS11-5G/75	2025x1100x900	NO	1600x750	2647
2350	BS11-6G/60	2350x1100x900	NO	1800x600	3060
	BSP11-6G/60	2350x1100x900	2145x300	1800x600	3069
	BS11-6G/75	2350x1100x900	NO	1800x750	2931

SHOW COOKING MODULE 125 DEEP

NEW



Length	Model	Dimensions	Hot plate shaft	Recess for cooking equipment	RRP (€)
2025	BSP12-5G/75	2025x1250x900	1645x300	1600x750	2989
	BS12-5G/75	2025x1250x900	NO	1600x750	2955
2350	BSP12-6G/75	2350x1250x900	2145x300	1800x750	3319
	BS12-6G/75	2350x1250x900	NO	1800x750	3287

BUFFET AND SHOW-COOKING DECORATION

DECORATION OPTIONS AND COUNTERTOP CHANGES

- The WHITE countertop is standard. Other available options offer an extra charge indicated below.
- Optionally, countertops can be manufactured in other colours and of other materials. (Consult prices.)

STANDARD	OPTION	OPTION	OPTION	OPTION
WHITE	RED	IVORY	GREEN	BLACK

OPTIONAL COLOUR CHANGE IN BUFFET COUNTERTOPS

Depth	Model	Dimensions	For models	RRP (€)
850	BDCE8-3GN	1375x850	BDP8-3G / BD8-3G	583
	BDCE8-4GN	1700x850	BDP8-4G / BD8-4G	693
	BCDE8-5GN	2025x850	BDP8-5G / BD8-5G	866
	BCDE8-6GN	2350x850	BDP8-6G / BD8-6G	937
1100	BCDE11-3GN	1375x1100	BDP11-3G / BD11-3G	772
	BCDE11-4GN	1700x1100	BDP11-4G / BD11-4G	871
	BCDE11-5GN	2025x1100	BDP11-5G / BD11-5G	1.167
	BCDE11-6GN	2350x1100	BDP11-6G / BD11-6G	1.238

OPTIONAL COLOUR CHANGE IN PLATES SHELVES

Depth	Model	Dimensions	For models	RRP (€)
850	BCE8-3GN	1375x850	BDP8-3G	160
	BCE8-4GN	1700x850	BDP8-4G	186
	BCE8-5GN	2025x850	BDP8-5G	220
	BCE8-6GN	2350x850	BDP8-6G	241
1100	BCE11-3GN	1375x1100	BDP11-3G	320
	BCE11-4GN	1700x1100	BDP11-4G	372
	BCE11-5GN	2025x1100	BDP11-5G	440
	BCE11-6GN	2350x1100	BDP11-6G	482

OPTIONAL COLOUR CHANGE IN SHOW-COOKING COUNTERTOPS

Depth	Model	Dimensions	For models	RRP (€)
1100	BSCE11-5G	2025x1100	BS11-5G / BSP11-5G	627
	BSCE11-6G	2350x1100	BS11-6G / BSP11-6G	712
1250	BSCE12-5G	2025x1250	BS12-5G / BSP12-5G	658
	BSCE12-6G	2350x1250	BS12-6G / BSP12-6G	764

OPTIONAL BACKSPLASH FOR BUFFET 85

- It enables the use of wall buffet (buffet 85cm deep).
- Manufactured of the same material as the countertop.

Model	Dimensions	Options for models	RRP (€)
BPT-3GN	1375x60x20	3 GN	119
BPT-4GN	1700x60x20	4 GN	124
BPT-5GN	2025x60x20	5 GN	155
BPT-6GN	2350x60x20	6 GN	173



FRONT PANELS DECORATION OPTIONS

STANDARD FINISH IN PLAIN LACQUERED WOOD

- Manufactured of waterproof DM wood with plain resistant lacquered finish.
- Lacquered finish, included in the price. Selection of any colour in the attached samples or any colour from the RAL range carries no extra cost.

WHITE RAL-9003	GREY RAL-7040	BLACK RAL-9005	MAROON RAL-3003	BLUE RAL-5015	GREEN RAL-6038
-------------------	------------------	-------------------	--------------------	------------------	-------------------



OPTIONAL WOOD METAL MELAMMINIC FINISH

- Optionally, waterproof wooden melamminic finish in the three colours shown below can be selected.
- As an option, personalized decorative panels can be manufactured, inquire prices.

WALNUT	WENGUE	OAK
--------	--------	-----

CHANGE IN MELAMMINIC FINISH BUFFET

Depth	Model	Dimensions	For models	RRP (€)
850	BDCD8-3GN	1375x900	BDP8-3G / BD8-3G	265
	BDCD8-4GN	1700x900	BDP8-4G / BD8-4G	284
	BDCD8-5GN	2025x900	BDP8-5G / BD8-5G	315
	BDCD8-6GN	2350x900	BDP8-6G / BD8-6G	342
1100	BDCD11-3GN	1375x900	BDP11-3G / BD11-3G	265
	BDCD11-4GN	1700x900	BDP11-4G / BD11-4G	284
	BDCD11-5GN	2025x900	BDP11-5G / BD11-5G	315
	BDCD11-6GN	2350x900	BDP11-6G / BD11-6G	342

CHANGE IN MELAMMINIC SHOW COOKING

Depth	Model	Dimensions	For models	RRP (€)
1100	BSCD11-5G	2025x900	BS11-5G/BSP11-5G	242
	BSCD11-6G	2350x900	BS11-6G/BSP11-6G	256
1250	BSCD12-5G	2025x900	BS12-5G/BSP12-5G	242
	BSCD12-6G	2350x900	BS12-6G/BSP12-6G	256

MODULES JOINTS KIT

- It enables the joint of 2 Buffets to make one set.
- Successive joints for the creation of lineal Buffet of any composition and length is easily achieved.

Model	RRP (€)
BKU	280



Under order, tray-sliders can be supplied in the buffets.

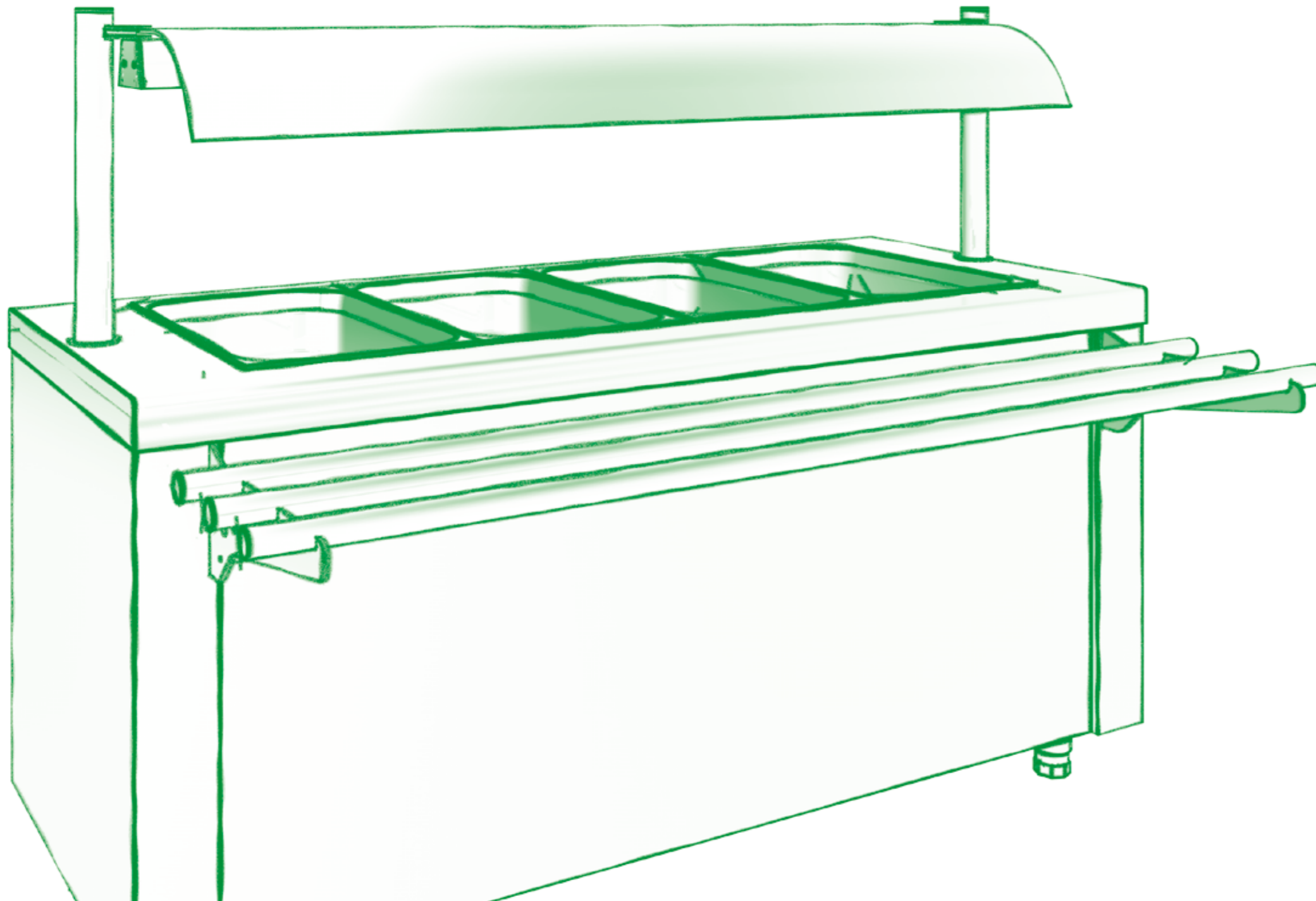

SELF SERVICE

Self cooled modules	page 178
Self cooled showcase modules	page 180
Self cooled central island modules	page 184
Self heated modules	page 185
Self heated tables modules	page 188
Self neutral cases modules	page 189
Plates dispensers and dishwasher baskets	page 191
Case and trolleys for plates dispensers	page 191
Bread, cutlery, trays, glasses, etc serving units	page 192
Lamp strip and heat lamp strip with brackets for self elements	page 193
Security glass for Self-service modules	page 194
Trays slides	page 194
Plinths and wheels kit	page 195
Self-service trays trolleys	page 195
Decorative front panels for children and adults Self-service	page 196
Children Self-service	page 198
Children Self cooled modules	page 200
Children Self showcase modules	page 201
Children Self heated modules	page 202
Children Self angled neutral modules	page 206
Bread, cutlery, trays, glasses, etc serving units	page 207
Bread, cutlery, trays, glasses, etc table top serving units	page 207
Trays slides, plinths, wheels, lamp strips and glass panels	page 207

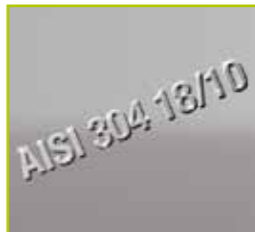

Maximum quality
Premium quality stainless steel AISI 304/10 products equipped with materials of European leading brands, designed for a professional and long-lasting use.



Easy installation
The constructive modular system composed by independent equipment sets simplifies the installation of Self-service. Its accessories have been designed to be quickly and easily installed.



Efficiency and technology
Eratos cooled Self-service modules are highly efficient thanks to the applied engineering, its technical design and the use of coolant gasses and insulation of leading-edge technology.



Hygiene and ergonomics
All materials used, together with the ample sanitary edges applied to the surfaces, ensure extreme hygiene. All elements have been designed complying with ergonomics and enabling an easy use.



Finish and design
The finish and design details are top range. Metal hardware, tempered glass, hanging doors, perfect adjustments. No welds, rivets, plastic or rails at sight.



Personalization
Eratos Self-service can be adapted and customized thanks to the removable panels in plain colour or wood, apart from having the possibility of adding adhesive vinyl sheets with any desired design.



Broad range
The ample variety of modules, combinations and available capacities enable the organization of Self-service lines which can exactly fit to the necessities of each project.



Children Self-service
Designed specifically for food and drink service for children. It has been created carefully taking into account the security of children as well as their use ergonomics. See page 198.

COOLED BOARDS



- Manufactured of satin 304 18/10 stainless steel.
- High density and thickness ecologic injected insulation.
- Built-in countertop, with 80mm fronts, and entirely welded.
- Refrigerated by means of copper serpentine tubing, condense gas unit R-290 and thermostat digital control.
- Board interval temperature $-4^{\circ}\text{C}/+4^{\circ}\text{C}$.
- Removable condenser unit in $\frac{3}{4}$ parts, which makes its maintenance and cleanness easy.
- Incorporated drainage.
- Robust height adjustable legs by means of hidden screw, with optional decorative plinths, see page 195.
- Single-phase voltage 230v/50Hz
- Stainless steel front decorative panel. Optionally, it can be supplied in plain colours or wood-effect; see page 196
- Optional gas R-134a (3,4GN), R452A (5,6GN).



Detail of refrigerated board.

OPEN COOLED BOARD



Model	Dimensions	Capacity	Power (W)	RRP (€)
SPFA-80/R	800x700x850	2GN	210	2.101
SPFA-120/R	1200x700x850	3GN	300	2.222
SPFA-160/R	1600x700x850	4GN	300	2.354
SPFA-200/R	2000x700x850	5GN	570	2.771
SPFA-225/R	2250x700x850	6GN	570	3.079

COOLED BOARD WITH RESERVE

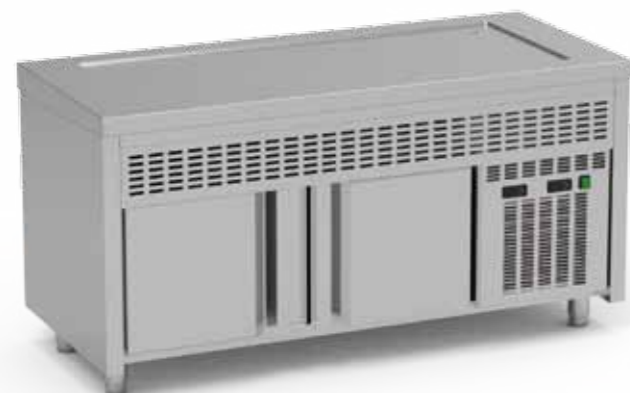

- Refrigerated by means of ventilated evaporator with automatic defrost. R-290.
- Additional control panel with illuminated switch and digital thermometer-thermostat $+4/+12^{\circ}\text{C}$.
- Cool reserve insulated with injected ecologic polyurethane 40kg/m³ density.
- Removable well GN1/1 rails separated 70mm.
 - Model SPFR-120: 4 pairs of rails.-Model SPFR-160: 6 pairs of rails.
 - Model SPFR-200 and SPFR-225: 10 pairs of rails.

Model	Dimensions	Capacity	Power (W)	RRP (€)
SPFR-120/R	1200x700x850	3GN	300	3.004
SPFR-160/R	1600x700x850	4GN	500	3.292
SPFR-200/R	2000x700x850	5GN	770	3.900
SPFR-225/R	2250x700x850	6GN	770	4.131

Heat unit, glass panel or tray slide not included in the price. See page 193-194

COOLED WELLS



- Manufactured of satin 304 18/10 stainless steel.
- Cooled well with rounded sanitary edges and capacity for GN wells maximum 200mm deep.
- Ecologic high density polyurethane insulation.
- Refrigerated by means of copper serpentine tubing, condense gas unit R-290 and thermostat digital control.
- Temperature interval in the well $0^{\circ}\text{C}/+5^{\circ}\text{C}$.
- Removable condenser unit, which makes its maintenance and cleanness easy.
- Built-in drainage.
- Countertop with front edges 80mm, entirely welded.
- Robust height adjustable legs by means of hidden screw, with optional decorative plinths, see page 195.
- Single-phase voltage 230v/50Hz
- Stainless steel front decorative panel. Optionally, it can be supplied in plain colours or wood-effect; see page 196
- Optional gas R-134a (3,4GN), R452A (5,6GN).

OPEN COOLED WELL



Model	Dimensions	Capacity	Power (W)	RRP (€)
SCFA-80/R	800x700x850	2GN-200	210	2.141
SCFA-120/R	1200x700x850	3GN-200	300	2.262
SCFA-160/R	1600x700x850	4GN-200	300	2.545
SCFA-200/R	2000x700x850	5GN-200	570	3.115
SCFA-225/R	2250x700x850	6GN-200	570	3.420

COOLED WELL WITH RESERVE



- Refrigerated by means of ventilated evaporator with automatic defrost. R-290.
- Additional control panel with illuminated switch and digital thermometer-thermostat $+4/+12^{\circ}\text{C}$.
- Cool reserve insulated with injected ecologic polyurethane 40kg/m³ density.
- Removable well GN1/1 rails separated 70mm.
 - Model SCFR-120: 4 pairs of rails.
 - Model SCFR-160: 6 pairs of rails.
 - Model SCFR-200 and SCFR-225: 10 pairs of rails.

Model	Dimensions	Capacity	Power (W)	RRP (€)
SCFR-120/R	1200x700x850	3GN-200	300	3.088
SCFR-160/R	1600x700x850	4GN-200	500	3.483
SCFR-200/R	2000x700x850	5GN-200	770	4.243
SCFR-225/R	2250x700x850	6GN-200	770	4.471

Heat unit, glass or tray slide not included in the price. See page 193-194. GN trays not included, see page 141.

COOLED SHOWCASE KIT WITH INSULATED BASE AND COUNTER



- Manufactured of satin 304 18/10 stainless steel.
- Cabinet upper front with front edges 80mm, entirely welded.
- Embedded lower base with rounded corners for a better hygiene and easy to clean with and high density ecologic insulation.
- Removable condenser unit, which makes its maintenance and cleanness easy.
- Refrigerated by means of ventilated evaporator, condenser unit with gas R-290 and thermostat digital control.
- Robust height adjustable legs by means of hidden screw, with optional decorative plinths, see page 195.
- Stainless steel front decorative panel. Optionally, it can be supplied in plain colours or wood-effect; see page 196
- Built-in drainage.
- Double glazing sliding doors on the service side and methacrylate hinged doors on the clients' side.
- 3 removable glass shelves.
- Low consumption interior illumination.
- Single-phase voltage 230v/50Hz
- Working temperature interval +4°C/+12°C.
- Optional gas R452A.

COOLED SHOWCASE KIT WITH INSULATED BASE AND NEUTRAL RESERVE



Model	Dimensions	Capacity	Power (W)	RRP (€)
SVPN-160/R	1600x700x1850	4GN	1100	5.096
SVPN-200/R	2000x700x1850	5GN	1205	5.907
SVPN-225/R	2250x700x1850	6GN	1205	6.798

COOLED SHOWCASE KIT WITH INSULATED BASE AND COOL RESERVE



- Refrigerated lower reserve with independent refrigerating unit by means of ventilated evaporator with automatic defrost. Gas R-290.
- Additional control panel with illuminated switch and digital thermometer-thermostat +4/+12°C.
- Reserve insulated with injected ecologic polyurethane 40kg/m3 density. Drainage included.
- Removable well GN1/1, rails separated 70mm.
 - Model SVPR-160: 4 pairs of rails.
 - Model SVPR-225: 10 pairs of rails.

Model	Dimensions	Capacity	Power (W)	RRP (€)
SVPR-160/R	1600x700x1850	4GN	1310	6.034
SVPR-200/R	2000x700x1850	5GN	1415	7.036
SVPR-225/R	2250x700x1850	6GN	1415	7.849

Trays slide not included in the price. See page 194.

COOLED SHOWCASE KIT WITH INSULATED WELL AND COUNTER



- Manufactured of satin 304 18/10 stainless steel.
- Cabinet upper front with front edges 80mm, entirely welded.
- Embedded well with rounded sanitary edges and capacity for GN wells maximum 200mm deep, which includes ecologic high density and thickness insulation.
- Removable condenser unit, which makes its maintenance and cleanness easy.
- Refrigerated by means of ventilated evaporator, condenser unit with gas R-290 and thermostat digital control.
- Robust height adjustable legs by means of hidden screw, with optional decorative plinths, see page 195.
- Stainless steel front decorative panel. Optionally, it can be supplied in plain colours or wood-effect; see page 196
- Built-in drainage.
- Double glazing sliding doors on the service side and methacrylate hinged doors on the client's side.
- 3 removable glass shelves.
- Low consumption interior illumination.
- Single-phase voltage 230v/50Hz
- Working temperature interval +4°C/+12°C.
- Optional gas R452A.

COOLED SHOWCASE KIT WITH INSULATED WELL AND NEUTRAL RESERVE



Model	Dimensions	Capacity	Power (W)	RRP (€)
SVCN-160/R	1600x700x1850	4GN-200	1100	5.288
SVCN-200/R	2000x700x1850	5GN-200	1205	6.250
SVCN-225/R	2250x700x1850	6GN-200	1205	7.138

COOLED SHOWCASE KIT WITH INSULATED BASE AND COOL RESERVE



- Inferior reserve with independent refrigerating unit worked by means of ventilated evaporator with automatic defrost. Gas R-290.
- Additional control panel with illuminated switch and digital thermometer-thermostat +4/+12°C.
- Cool reserve insulated with injected ecologic polyurethane 40kg/m3 density. Built-in drainage.
- Removable well GN1/1 rails separated 70mm.
- Guías extraíbles para cubetas GN1/1 separadas 70mm.
 - Model SVCR-160 and SVCR-200: 4 pairs of rails.
 - Model SVCR-225: 10 pairs of rails.

Model	Dimensions	Capacity	Power (W)	RRP (€)
SVCR-160/R	1600x700x1850	4GN-200	1310	6.226
SVCR-200/R	2000x700x1850	5GN-200	1415	7.379
SVCR-225/R	2250x700x1850	6GN-200	1415	8.190

Trays slide not included in the price. See page 194.

OPEN COOLED SHOWCASE KIT WITH INSULATED BASE AND COUNTER



- Manufactured of satin 304 18/10 stainless steel.
- Cabinet upper front with front edges 80mm, entirely welded.
- Embedded lower base with rounded corners for a better hygiene and cleanness.
- Ecologic high density and thickness insulation.
- Double glazing sliding doors on the service side and night rolling shutter on the clients' side.
- Refrigerated by means of ventilated evaporator, condenser unit with gas R-290 and thermostat digital control.
- Robust height adjustable legs by means of hidden screw, with optional decorative plinths, see page 195.
- Stainless steel front decorative panel. Optionally, it can be supplied in plain colours or wood-effect; see page 196.
- 3 easily removable glass shelves.
- Working temperature interval +4°C/+12°C.
- Low consumption interior illumination.
- Apt to keep the product refrigerated during the service time.
- Built-in drainage.
- Single-phase voltage 230v/50Hz .
- Optional gas R452A.

OPEN COOLED SHOWCASE KIT WITH INSULATED BASE AND COOL RESERVE



Model	Dimensions	Capacity	Power (W)	RRP (€)
SVPPN-160/R	1600x700x2140	4GN	1205	6.693

OPEN COOLED SHOWCASE KIT WITH INSULATED BASE AND COOL RESERVE



- Inferior reserve with independent refrigerating unit worked by means of ventilated evaporator with automatic defrost. Gas R-290.
- Removable condenser unit in 3/4 parts to facilitate its maintenance and cleaning.
- Additional control panel with illuminated switch and digital thermometer-thermostat +4/+12°C.
- Cool reserve insulated with injected ecologic polyurethane 40kg/m3 density.
- 4 pairs of removable rails for wells GN1/1, separated 70mm.

Model	Dimensions	Capacity	Power (W)	RRP (€)
SVPPR-160/R	1600x700x2140	4GN	1200	7.631

Trays slide not included in the price. See page 194.

OPEN COOLED SHOWCASE WITH INSULATED BASE



- Manufactured of satin 304 18/10 stainless steel.
- Embedded lower base with rounded corners for a better hygiene and cleanness.
- Ecologic high density and thickness injected polyurethane insulation.
- Double glazing sliding doors on the service side and night rolling shutter on the clients' side.
- 3 interior easily removable glass shelves.
- Refrigerated by means of ventilated evaporator, condenser unit with gas R-290 and thermostat digital control.
- Working temperature interval +4°C/+12°C.
- Low consumption interior illumination.
- Incorporated condenser unit.
- Apt to keep the product refrigerated during the service time, approx. 2hs.
- Optional gas R452A.

Model	Dimensions	Consumption (W)	Ref.Power (W)	Voltage	RRP (€)
SVSP-160/R	1525x655x1355	1200	1210	230V/50Hz	4.346

SEL-SERVICE COOLED SHOWCASE WITH INSULATED BASE



- Manufactured of satin 304 18/10 stainless steel.
- Refrigerated by means of ventilated evaporator, condenser unit with gas R-290 and thermostat digital control.
- Working temperature interval +4°C/+12°C.
- Embedded lower base with rounded corners for a better hygiene and cleanness.
- Ecologic high density and thickness injected polyurethane insulation.
- Double glazing sliding doors on the service side and methacrylate hinged doors on the clients' side.
- Built-in drainage.
- 3 interior easily removable glass shelves.
- Low consumption interior illumination.
- Incorporated condenser unit.
- Optional gas R452A.

Model	Dimensions	Consumption (W)	Ref.Power (W)	Voltage	RRP (€)
SVSM-160/R	1525x655x1355	1100 W	1210	230V/50Hz	3.579
SVSM-200/R	1925x655x1355	1205 W	1650	230V/50Hz	3.994
SVSM-225/R	2175x655x1355	1205 W	1650	230V/50Hz	4.408

COOLED CENTRAL ISLAND

- Manufactured of satin 304 18/10 stainless steel.
- Cabinet countertop with front edges 80mm, entirely welded.
- Robust height adjustable legs by means of hidden screw, with optional decorative plinths, see page 195.
- Stainless steel front decorative panel. Optionally, it can be supplied in plain colours or wood-effect; see page 196.
- Removable condenser unit in 3/4 parts for easy maintenance and cleanness.
- Single-phase voltage 230v/50Hz.



CENTRAL ISLAND COLD BASE

- Embedded countertop with ecologic high density insulation and built-in drainage.
- Refrigeration by means of copper serpentine tubing, condenser unit with gas R-290 and digital thermostat control.
- Working temperature interval in the well $-4^{\circ}\text{C}/+4^{\circ}\text{C}$.
- Optional gas R-134a in 4GN and R452A in 5,6GN.

Model	Dimensions	Capacity	Power (W)	RRP (€)
SPFC-160/R	1600x700x850	4GN	300	2.880
SPFC-200/R	2000x700x850	5GN	570	3.415
SPFC-225/R	2250x700x850	6GN	570	3.786

CENTRAL ISLAND COOLED WELL

- Embedded well with rounded edges and capacity for GN wells maximum 200mm deep, with built-in drainage.
- Ecologic polyurethane insulation.
- Refrigeration by means of copper serpentine tubing, condenser unit with gas R-290 and digital thermostat control.
- Working temperature interval in the well $0/+5^{\circ}\text{C}$.
- Optional gas R-134a in 4GN and R452A in 5,6GN.

Model	Dimensions	Capacity	Power (W)	RRP (€)
SCFC-160/R	1600x700x850	4GN-200	300	3.072
SCFC-200/R	2000x700x850	5GN-200	570	3.759
SCFC-225/R	2250x700x850	6GN-200	570	4.127

LATERAL PLATES RACKS

- Manufactured of satin 304 18/10 stainless steel.
- Capacity for 2 piles of plates, of up to $\varnothing 30\text{cm}$.
- Easy to install.

Model	Dimensions	RRP (€)
SLP	600x330x150	197



Lamp strip, tray slides and lateral plates racks not included in the price. See page 193-194. GN trays not included, see page 141.

HUMID BEIN-MARIE

- Manufactured of satin 304 18/10 stainless steel.
- Well with rounded sanitary edges and capacity for GN wells maximum 200mm deep.
- Fireproof ecologic polyurethane insulation.
- Well heating by means of silicone resistances, which improve the efficiency and reduce the electric consumption.
- Adjustable well temperature $+50^{\circ}\text{C}/+90^{\circ}\text{C}$.
- Inlet tap of 1/2" and drainage of 3/4" with ball valve mechanism and overflow pipe.
- Countertop with front edges 80mm, entirely welded.
- Robust height adjustable legs by means of hidden screw, with optional decorative plinths, see page 195.
- Stainless steel front decorative panel. Optionally, it can be supplied in plain colours or wood-effect; see page 196.
- Models 3GN, 4GN and 5GN: Single-phase voltage 230v/50Hz.
- Model 6GN: Three-phase voltage 400v/50Hz.



OPEN HUMID BEIN-MARIE

Model	Dimensions	Capacity	Power (W)	RRP (€)
SBMA-80	800x700x850	2GN-200	1000	1.766
SBMA-120	1200x700x850	3GN-200	2000	1.968
SBMA-160	1600x700x850	4GN-200	3000	2.300
SBMA-200	2000x700x850	5GN-200	3000	3.096
SBMA-225	2250x700x850	6GN-200	4000	3.310



HUMID BEIN-MARIE WITH NEUTRAL RESERVE

- Suspended sliding doors of smooth slide by means of rail with ball bearing.

Model	Dimensions	Capacity	Power (W)	RRP (€)
SBMN-120	1200x700x850	3GN-200	2000	2.392
SBMN-160	1600x700x850	4GN-200	3000	2.787
SBMN-200	2000x700x850	5GN-200	3000	3.456
SBMN-225	2250x700x850	6GN-200	4000	3.848



HUMID BEIN-MARIE WITH HEATED RESERVE

- Interior heating by removable ventilated resistances with security thermal klixon.
- Double wall and glass fibre integral insulation, in the case as well as doors.
- Additional control panel with digital thermometer/thermostat and illuminated switch. Adjustable temperature $+50^{\circ}\text{C}/+75^{\circ}\text{C}$.
- Suspended sliding doors of smooth slide.

Model	Dimensions	Capacity	Power (W)	RRP (€)
SBMR-120	1200x700x850	3GN-200	4100	2.570
SBMR-160	1600x700x850	4GN-200	5100	2.907
SBMR-200	2000x700x850	5GN-200	5600	3.816
SBMR-225	2250x700x850	6GN-200	6600	3.947



Lamp strip, glass or trays slide not included in the price. See page 193-194. GN trays not included, see page 141.

DRY BEIN-MARIE



- Manufactured of satin 304 18/10 stainless steel.
- Well with rounded sanitary edges and capacity for GN wells maximum 150mm deep.
- Fireproof ecologic polyurethane insulation.
- Well heating by means of shielded resistances protected by drilled double bottom.
- Removable resistances to facilitate its cleanness.
- Adjustable well temperature +50°C/+90°C.
- Countertop with front edges 80mm, entirely welded.
- Robust height adjustable legs by means of hidden screw, with optional decorative plinths, see page 195.
- Stainless steel front decorative panel. Optionally, it can be supplied in plain colours or wood-effect; see page 196
- Single-phase voltage 230v/50Hz.

OPEN DRY BEIN-MARIE

Model	Dimensions	Capacity	Power (W)	RRP (€)
SBSA-80	800x700x850	2GN-150	1750	1.700
SBSA-120	1200x700x850	3GN-150	1750	1.902
SBSA-160	1600x700x850	4GN-150	2500	2.234
SBSA-200	2000x700x850	5GN-150	2950	3.031
SBSA-225	2250x700x850	6GN-150	3500	3.245

DRY BEIN-MARIE WITH NEUTRAL RESERVE

- Suspended sliding doors of smooth slide by means of rail with ball bearing.

Model	Dimensions	Capacity	Power (W)	RRP (€)
SBSN-120	1200x700x850	3GN-150	1750	2.327
SBSN-160	1600x700x850	4GN-150	2500	2.722
SBSN-200	2000x700x850	5GN-150	2950	3.391
SBSN-225	2250x700x850	6GN-150	3500	3.783

DRY BEIN-MARIE WITH HEATED RESERVE

- Interior heating by removable ventilated resistances with security thermal klixon.
- Double wall and glass fibre integral insulation, in the case as well as doors.
- Additional control panel with digital thermometer/thermostat and illuminated switch. Adjustable temperature +50°C/+75°C.
- Suspended sliding doors of smooth slide.

Model	Dimensions	Capacity	Power (W)	RRP (€)
SBSR-120	1200x700x850	3GN-150	3850	2.505
SBSR-160	1600x700x850	4GN-150	4600	2.841
SBSR-200	2000x700x850	5GN-150	5550	3.751
SBSR-225	2250x700x850	6GN-150	6100	3.881

Lamp strip, glass or trays slide not included in the price. See page 193-194. GN trays not included, see page 141.

HUMID AND DRY BEIN-MARIE CENTRAL ISLAND

- Manufactured of satin 304 18/10 stainless steel.
- Well with rounded sanitary edges.
- Capacity for GN wells maximum 200mm deep.
- Fireproof ecologic polyurethane insulation.
- Countertop with front edges 80mm, entirely welded.
- Adjustable well temperature +50°C/+90°C.
- Robust height adjustable legs by means of hidden screw, with optional decorative plinths, see page 195.
- Stainless steel front decorative panel. Optionally, it can be supplied in plain colours or wood-effect; see page 196.
- Single-phase voltage 230v/50Hz, except for model SBMC-225 (three-phase 400V/50Hz).



HUMID BEIN-MARIE ISLAND

- Well heating by means of silicone resistances, which improve the efficiency and reduce the electric consumption.
- Inlet tap of 1/2" and drainage of 3/4" ball valve mechanism and spillway tubing.

Model	Dimensions	Capacity	Power (W)	RRP (€)
SBMC-160	1600x700x850	4GN-200	3000	2.613
SBMC-200	2000x700x850	5GN-200	3000	3.519
SBMC-225	2250x700x850	6GN-200	4000	3.761

DRY BEIN-MARIE ISLAND

- Well heating by means of silicone resistances, which improves the efficiency and reduce the electric consumption.
- Inlet tap of 1/2" and drainage of 3/4" ball valve mechanism and spillway tubing.

Model	Dimensions	Capacity	Power (W)	RRP (€)
SBSC-160	1600x700x850	4GN-150	2500	2.539
SBSC-200	2000x700x850	5GN-150	2950	3.444
SBSC-225	2250x700x850	6GN-150	3500	3.687

GLASS-CERAMIC CENTRAL ISLAND

- Manufactured of satin 304 18/10 stainless steel.
- Glass-ceramic SCHOTT CERAN® 6mm thick.
- Heating by silicone resistances adjustable by means of thermostat with security thermal klixon.
- Countertop with front edges 80mm, entirely welded.
- Robust height adjustable legs by means of hidden screw, with optional decorative plinths, see page 195.
- Stainless steel front decorative panel. Optionally, it can be supplied in plain colours or wood-effect; see page 196.
- Single-phase voltage 230v/50Hz.

Model	Dimensions	Capacity	Power (W)	RRP (€)
SVTC-160	1600x700x850	4GN	1350	3.164
SVTC-200	2000x700x850	5GN	2250	4.063
SVTC-225	2250x700x850	6GN	3300	4.590

Lam strip, glass or trays slide not included in the price. See page 193-194. GN trays not included, see page 141.

GLASS-CERAMIC MODULES



- Manufactured of satin 304 18/10 stainless steel.
- Glass-ceramic SCHOTT CERAN® 6mm thick.
- Heating by silicone resistances adjustable by means of thermostat with security thermal klixon.
- Adjustable well temperature +50°C/+90°C.
- Countertop with front edges 80mm, entirely welded.
- Robust height adjustable legs by means of hidden screw, with optional decorative plinths, see page 195.
- Stainless steel front decorative panel. Optionally, it can be supplied in plain colours or wood-effect; see page 196.
- Single-phase voltage 230v/50Hz.

OPEN GLASS-CERAMIC

Model	Dimensions	Capacity	Power (W)	RRP (€)
SVTA-80	800x700x850	2GN	1100	1.987
SVTA-120	1200x700x850	3GN	1650	2.293
SVTA-160	1600x700x850	4GN	2200	2.784
SVTA-200	2000x700x850	5GN	2750	3.575
SVTA-225	2250x700x850	6GN	3300	4.039

GLASS-CERAMIC WITH NEUTRAL RESERVE

- Suspended sliding doors of smooth slide by means of guide rails with ball bearings.

Model	Dimensions	Capacity	Power (W)	RRP (€)
SVTN-120	1200x700x850	3GN	1650	2.717
SVTN-160	1600x700x850	4GN	2200	3.272
SVTN-200	2000x700x850	5GN	2750	3.935
SVTN-225	2250x700x850	6GN	3300	4.578

GLASS-CERAMIC WITH HEATED RESERVE

- Interior heating by removable ventilated resistances.
- Double wall and glass fibre integral insulation.
- Additional control panel with digital thermostat.
- Adjustable temperature +50°C/+75°C.
- Suspended sliding doors of smooth slide.

Model	Dimensions	Capacity	Power (W)	RRP (€)
SVTR-120	1200x700x850	3GN	3750	2.895
SVTR-160	1600x700x850	4GN	4300	3.391
SVTR-200	2000x700x850	5GN	5350	4.295
SVTR-225	2250x700x850	6GN	5900	4.676

HEATED TABLE



- Manufactured of satin 304 18/10 stainless steel.
- Interior heating by removable ventilated resistances.
- Double wall and glass fibre integral insulation.
- Digital control panel and illuminated switch.
- Adjustable temperature +50°C/+75°C.
- Suspended sliding doors of smooth slide.
- Stainless steel front decorative panel. Optionally, it can be supplied in plain colours or wood-effect.
- Single-phase voltage 230v/50Hz.

Model	Dimensions	Power (W)	RRP (€)
SMC-120	1200x700x850	2100	1.837
SMC-160	1600x700x850	2600	2.193
SMC-180	1800x700x850	3100	2.605
SMC-200	2000x700x850	3100	2.842
SMC-225	2250x700x850	3100	3.037

NEUTRAL MODULES

- Manufactured of satin 304 18/10 stainless steel.
- Countertop with front edges 80mm, entirely welded.
- Robust height adjustable legs by means of hidden screw, with optional decorative plinths, see page 195.
- Stainless steel front decorative panel. Optionally, it can be supplied in plain colours or wood-effect; see page 196.



OPEN NEUTRAL MODULES

Model	Dimensions	RRP (€)
SNA-40	400x700x850	644
SNA-50	500x700x850	725
SNA-60	600x700x850	753
SNA-80	800x700x850	861
SNA-100	1000x700x850	971
SNA-120	1200x700x850	1.073
SNA-140	1400x700x850	1.177
SNA-160	1600x700x850	1.243
SNA-180	1800x700x850	1.308
SNA-200	2000x700x850	1.375

NEUTRAL MODULES WITH SLIDING DOORS

- Suspended sliding doors of smooth slide by means of guide rails with ball bearings, except model SNB-80, which contains two hinged doors.

Model	Dimensions	RRP (€)
SNB-80	800x700x850	1.153
SNC-100	1000x700x850	1.184
SNC-120	1200x700x850	1.311
SNC-140	1400x700x850	1.439
SNC-160	1600x700x850	1.518
SNC-180	1800x700x850	1.597
SNC-200	2000x700x850	1.676

CASH MODULES

- It includes drawer.
- Lead-through hole with removable lid.
- It includes electric pre-installation with socket.

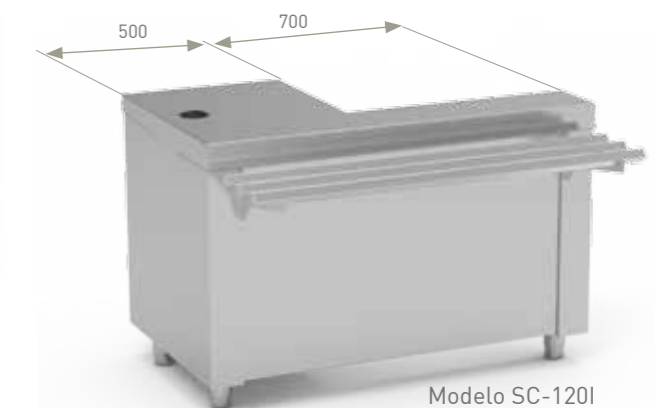

Model	Dimensions	RRP (€)
SC-120I	1200x700x850	1.089
SC-120D	1200x700x850	1.089

Brackets, glass panel and slides not included in the price; see page 193-194.

ANGLED NEUTRAL MODULES

- Manufactured of satin 304 18/10 stainless steel.
- Countertop with front edges 80mm, entirely welded.
- Robust height adjustable legs by means of hidden screw, with optional decorative plinths, see page 195.
- Stainless steel front decorative panel. Optionally, it can be supplied in plain colours or wood-effect; see page 196.



OPEN ANGLED MODULE 45°

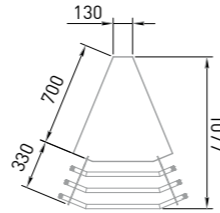

Model	Dimensions	RRP (€)
SAA-45	665x700x850	857

CLOSED ANGLED MODULE 45°

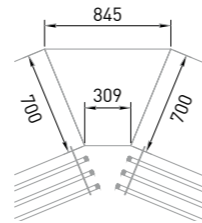

Model	Dimensions	RRP (€)
SAC-45	845x650x850	920

OPEN ANGLED MODULE 90°

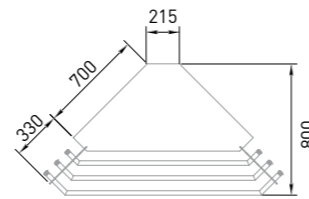

Model	Dimensions	RRP (€)
SAA-90	1205x585x850	1.099

CLOSED ANGLED MODULE 90°

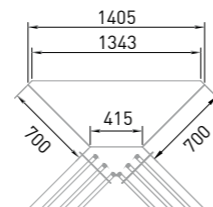

Model	Dimensions	RRP (€)
SAC-90	1405x525x850	1.052

Trays slides not included. See page 194.

DISPENSER MODULES

- Manufactured of satin 304 18/10 stainless steel.
- Countertop with front edges 80mm, entirely welded.
- Robust height adjustable legs by means of hidden screw, with optional decorative plinths, see page 195.
- Stainless steel front decorative panel. Optionally, it can be supplied in plain colours or wood-effect; see page 196.

NEUTRAL AND HEATED PLATES DISPENSER

- Adjustable spring system, which keeps the plates on the countertop level.
- The heated models include illuminated switch and adjustable electric resistance by analogical thermostat.
- Apt for plates of Ø 210 to 278 mm.
- Optional plastic lid for a better thermal insulation.

Model	Type	N° of plates (approx)	Dimensions	Power (W)	RRP (€)
SDPN-40	Neutral	45	400x700x850	-	1.303
SDPN-80	Neutral	90	800x700x850	-	1.691
SDPC-40	Heated	45	400x700x850	500	1.695
SDPC-80	Heated	90	800x700x850	1000	2.642
TDP	Lid	-	ø365x80	-	58



CUTLERY BASKET DISPENSER

- Apt for baskets of 500x500mm.
- Adjustable spring system, which keeps the plates on the countertop level.

Model	N° of basket (approx)	Dimensions	RRP (€)
SDC-80	10 de h=50	800x700x850	1.976



MODULE FOR PLATES DISPENSER RACK

- Designed to lodge a hot plates dispenser trolley model CDPC, not included.
- It includes electrical pre-installation with socket for the connexion of CDPC dispenser.
- Trolley DCPC and trays slides not included.

Model	Dimensions	RRP (€)
SHDP-120	1200x700x850	1.232

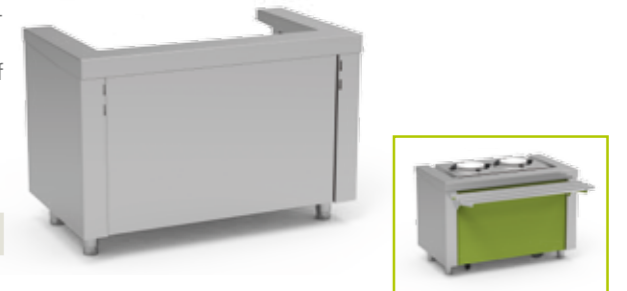

HOT PLATES DISPENSER TROLLEY

- Manufactured of satin 304 18/10 stainless steel.
- Equipped with transport handle and 4 revolving wheels, 2 with brakes.
- Apt for plates of 210 to 278mm diameter.
- Adjustable spring system, which keeps the plates on the countertop level.
- Illuminated switch and adjustable electric resistance by analogical thermostat.
- Optionally, a plastic lid can be included for a better thermal insulation, model TDP.

Model	N° of plates (approx)	Dimensions	Power (W)	RRP (€)
CDPC	90	920x600x850	1000	1.874
TDP	Tapa	ø365x80	-	58



Trays slides not included. See page 194.

COUNTERTOP BREAD SERVING UNIT



- Manufactured of satin 304 18/10 stainless steel.
- It includes plastic cutlery rack.

Model	Dimensions	RRP (€)
SPNS	710x700x500	526

BREAD, CUTLERY AND GLASSES SERVING UNITS

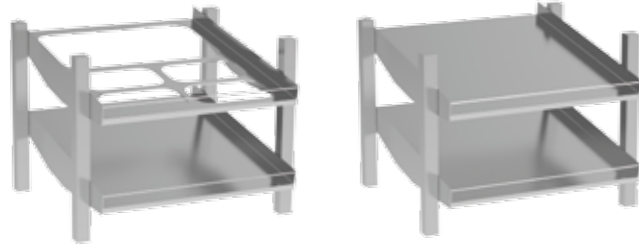

Model SDPS

Model SDVS

- Manufactured of satin 304 18/10 stainless steel.
- Tube legs 40x60mm.
- Two possible clamping systems: Adjustable legs or bolted to the countertop, both included in series.
- In model SPDS, the upper tray includes shafts for a well GN1/1 and 4 GN 1/4 (the wells are not included, see stainless steel wells KCDP).



SDPS + KCDP

Model	Dispenser	Dimensions	RRP (€)
SDPS	Bread, cutlery, glasses	715x690x665	636
SDVS	Glasses	715x690x665	762
KCDP	GN wells kit	1 GN 1/1 100 4 GN 1/4 100	107,5

STANDARD BREAD, CUTLERY, GLASSES AND TRAYS SERVING UNITS

- Manufactured of satin 304 18/10 stainless steel.
- Tube legs 40x60mm.
- Model SPNP includes plastic cutlery rack.
- Robust height adjustable legs by means of hidden screw.
- The upper shelves in models SPNG and SPDG, include shafts

for 3 wells GN1/1 and 4 wells GN 1/4 (the wells are not included in the price). To facilitate the service we include the SKCD stainless steel wells kit where 3 SST wells are supplied GN1/1-100 and 4 SST wells GN1/4-100.



Model SPNP

Model SDVP

Model SPNG+SKCD

Model SPDG+SKCD

Model	Dimensions	Dispenser	Nº of placements	RRP (€)
SPNP	720x700x1560	Bread, cutlery, glasses and trays	4	1.124
SDVP	720x700 x1560	Glasses	7	1.257
SPNG	720x700 x1560	Bread, cutlery, glasses and trays	4	1.499
SPDG	720x1400x1560	Bread, cutlery, glasses and trays	7+4	2.563
SKCD	GN wells kit	3 GN1/1-100 and 4 wells GN1/4-100	-	167,3

N
N

SNEEZEGUARDS KIT FOR SELF-SERVICE MODELS

NEW DESIGN

- Manufactured of satin 304 18/10 stainless steel.
- Tube legs 40x60mm.
- Model with light: lighting by means of two LED strips, IP-67.
- Heat unit with light models: Lighting with halogen lamps and heating by means of ceramic resistances.

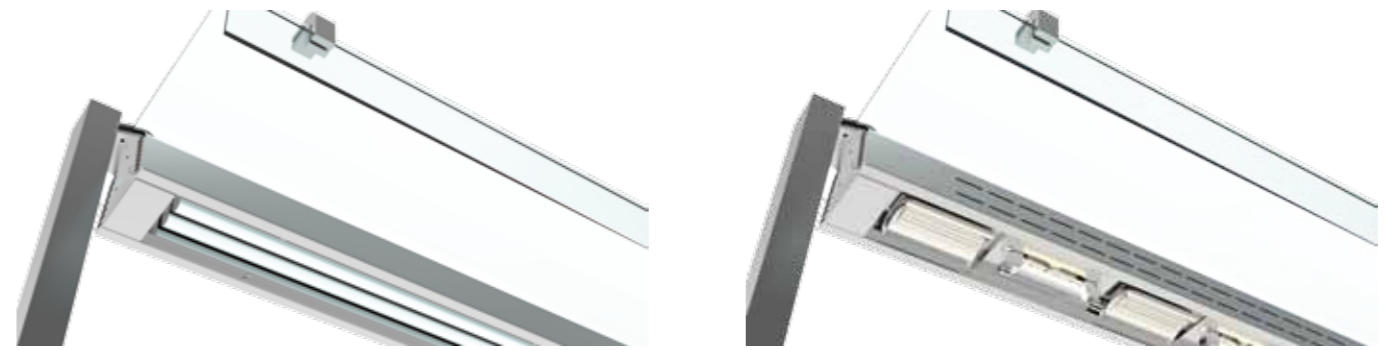

SIMPLE BRACKETS WITH LAMP STRIP

LED LAMP STRIP			
Model	Dimensions	Power (W)	RRP (€)
SPLS-2GN	764x136x440	8	508
SPLS-3GN	1164x136x440	16	543
SPLS-4GN	1564x136x440	32	585
SPLS-5GN	1964x136x440	32	621
SPLS-6GN	2114x136x440	32	678



Glass panels not included

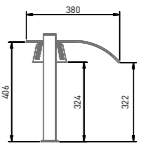

HEAT LAMP STRIP WITH HALOGEN AND CERAMIC			
Model	Dimensions	Power (W)	RRP (€)
PLCS-2GN	764x136x440	580	569
PLCS-3GN	1164x136x440	910	621
PLCS-4GN	1564x136x440	1240	676
PLCS-5GN	1964x136x440	1570	760
PLCS-6GN	2114x136x440	1900	842

DOUBLE BRACKETS WITH LAMP STRIP

LED LAMP STRIP			
Model	Dimensions	Power (W)	RRP (€)
SPLD-2GN	764x136x645	8	609
SPLD-3GN	1164x136x645	16	644
SPLD-4GN	1564x136x645	32	686
SPLD-5GN	1964x136x645	32	722
SPLD-6GN	2114x136x645	32	779

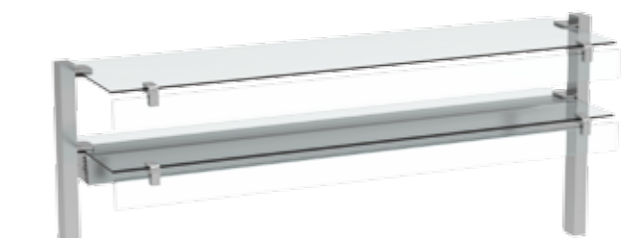

Glass panels not included

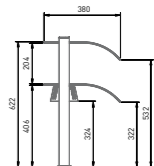

HEAT LAMP STRIPS WITH HALOGEN AND CERAMIC			
Model	Dimensions	Power (W)	RRP (€)
PLCD-2GN	764x136x645	580	670
PLCD-3GN	1164x136x645	910	722
PLCD-4GN	1564x136x645	1240	777
PLCD-5GN	1964x136x645	1570	861
PLCD-6GN	2114x136x645	1900	943

PAIR OF NEUTRAL BRACKETS

Model	Type	Dimensions	Suitable for glass	RRP (€)
SSP	Simple	40x60x440	2GN/3GN/4GN	226
SS5GN	Simple	1964x75x440	5GN	272
SS6GN	Simple	2114x75x440	6GN	274
SDP	Double	40x60x440	2GN/3GN/4GN	327
SDP5	Double	1964x75x645	5GN	428
SDP6	Double	2114x75x645	6GN	430



SECURITY GLASS PANELS FOR SELF-SERVICE MODELS

- Security tempered glass panels.
- Easy to install.
- For the clamping of the sneezeguard glass to the top glass, the hardware kit KHV-2 or KHV-3 is necessary.
- For the clamping of the front glass to the top glass and with the upper part of the Self-service, the hardware kit KH-2 or KH-3 is necessary

SIMPLE SELF-SERVICE GLASS



Model	Dimensions	RRP (€)
SCRR-2GN	623x380x6	111
SCRR-3GN	1023x380x6	124
SCRR-4GN	1423x380x6	143
SCRR-5GN	1823x380x6	176
SCRR-6GN	2073x380x6	207

DOUBLE SELF-SERVICE GLASS



Model	Dimensions	RRP (€)
SCRI-4GN	1423x540x6	170
SCRI-5GN	1823x540x6	210
SCRI-6GN	2073x540x6	248

SNEEZEGUARD SELF-SERVICE GLASS



Upper glass not included

Model	Dimensions	RRP (€)
SCRV-2GN	623x90x6	73
SCRV-3GN	1023x90x6	81
SCRV-4GN	1423x90x6	93
SCRV-5GN	1823x90x6	114
SCRV-6GN	2073x90x6	135

FRONT SELF-SERVICE GLASS



Upper glass not included

Model	Dimensions	RRP (€)
SCRF-2GN	623x385x6	111
SCRF-3GN	1023x385x6	124
SCRF-4GN	1423x385x6	143
SCRF-5GN	1823x385x6	176
SCRF-6GN	2073x385x6	207

HARDWARE KIT SNEEZEGUARD GLASS INSTALLATION

Model	For glass installation	Nº of 2-piece kts	RRP (€)
KHV-2	2/3/4GN	2	84
KHV-3	5/6GN	3	126

HARDWARE KIT FRONT GLASS INSTALLATION

Model	For glass installation	Nº of 2-piece kts	RRP (€)
KH-2	2/3/4GN	2 + 2	130
KH-3	5/6GN	3 + 3	195



Model KH -2

WHEELS KIT

- Wheels of Ø125mm.
- 2 wheels with brakes are supplied in each kit

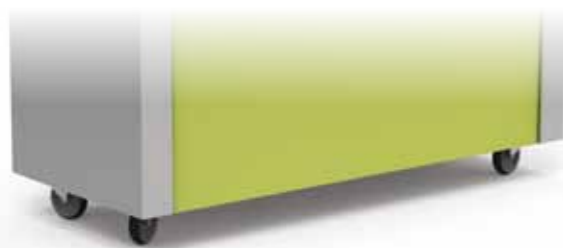

For modules	Model	Nº of wheels	RRP (€)
≤ 2000 mm	KRM4	4	192
> 2000 mm	KRM6	6	288

PLINTHS

- Manufactured of satin 304 18/10 stainless steel.
- Easy to install.

Model	Type	Dimensions	RRP (€)
SZ-40	Frontal	400x100x135	58
SZ-60	Frontal	600x100x135	74
SZ-80	Frontal	800x100x135	92
SZ-100	Frontal	1000x100x135	126
SZ-120	Frontal	1200x100x135	142
SZ-140	Frontal	1400x100x135	155
SZ-160	Frontal	1600x100x135	189
SZ-180	Frontal	1800x100x135	224
SZ-200	Frontal	2000x100x135	261
SZ-225	Frontal	2250x100x135	299
SZAA-45	Open angle 45°..	-	92
SZAC-45	Closed angle 45°	-	87
SZAA-90	Open angle 90°	-	118
SZAC-90	Closed angle 90°	-	108
SZL-70	Lateral	373x100x135	82
SZLI	Lateral island(2 units)	160x100x135	151

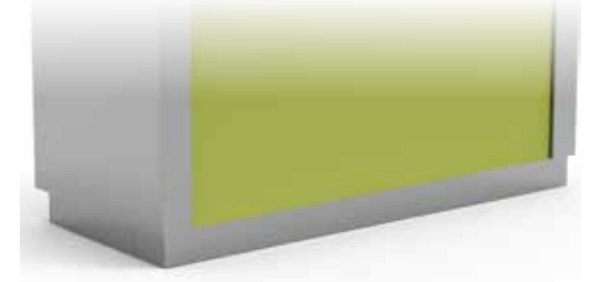

TRAYS SLIDES

- Models SCB - manufactured of satin 304 18/10 stainless steel.
- Models SCS - Manufactured of Solid-Surface from resins and minerals, which provide great resistance and hygiene, with AISI 304 stainless steel inserts.
- Easy to install without screws or tools.
- **Optionally, on order, the trays slides can be placed on the rear part**

Type	Dimensions	OF STAINLESS STEEL		ON SOLID-SURFACE	
		Model	RRP (€)	Model	RRP (€)
Lineal	400x330x130	SCB-40	176	SCS-40	383
Lineal	600x330x130	SCB-60	184	SCS-60	402
Lineal	800x330x130	SCB-80	190	SCS-80	412
Lineal	1000x330x130	SCB-100	197	SCS-100	428
Lineal	1200x330x130	SCB-120	211	SCS-120	458
Lineal	1400x330x130	SCB-140	226	SCS-140	488
Lineal	1600x330x130	SCB-160	243	SCS-160	526
Lineal	1800x330x130	SCB-180	264	SCS-180	578
Lineal	2000x330x130	SCB-200	293	SCS-200	635
Lineal	2250x330x130	SCB-225	321	SCS-225	698
Angular 45°	-	SCBAA-45	290	SCSAA-45	629
Angular 90°	-	SCBAA-90	342	SCSAA-90	741



STAINLESS STEEL



SOLID-SURFACE

SELF-SERVICE TRAYS TROLLEYS

NEW

- Manufactured of satin 304 18/10 stainless steel.
- It enables the lodging of trays of 290/380mm wide and 530mm deep.
- Rails welded to the structure, with stop.
- 4 low-noise revolving wheels of Ø125mm (2 with brakes) and rubber bumpers.

Dimensions	Nº of rails	DISASSEMBLED		WELDED	
		Model	RRP (€)	Model	RRP (€)
445x565x1825	12	CBAD-12	457	CBA-12	502
860x565x1825	24	CBAD-24	619	CBA-24	694



ADULTS AND CHILDREN DECORATIVE FRONT PANELS

- Panels manufactured of removable and exchangeable laminated steel.
- They are supplied assembled.
- Finish in plain colours, wood effect or special designs.



PLAIN COLOUR PANELS



TYPE	YELLOW RAL-1023	ORANGE RAL-2008	RED RAL-3020	MAROON RAL-3003	BLUE RAL-5003	GREEN RAL-6001	WHITE RAL-9003	GRAY RAL-7040	BEIGE RAL-1015	BLACK RAL-9005	RRP (€)
Front 400	SP-40-AM	SP-40-NA	SP-40-RO	SP-40-BU	SP-40-AZ	SP-40-VE	SP-40-BL	SP-40-GR	SP-40-BE	SP-40-NE	48
Front 600	SP-60-AM	SP-60-NA	SP-60-RO	SP-60-BU	SP-60-AZ	SP-60-VE	SP-60-BL	SP-60-GR	SP-60-BE	SP-60-NE	52
Front 800	SP-80-AM	SP-80-NA	SP-80-RO	SP-80-BU	SP-80-AZ	SP-80-VE	SP-80-BL	SP-80-GR	SP-80-BE	SP-80-NE	55
Front 1000	SP-100-AM	SP-100-NA	SP-100-RO	SP-100-BU	SP-100-AZ	SP-100-VE	SP-100-BL	SP-100-GR	SP-100-BE	SP-100-NE	58
Front 1200	SP-120-AM	SP-120-NA	SP-120-RO	SP-120-BU	SP-120-AZ	SP-120-VE	SP-120-BL	SP-120-GR	SP-120-BE	SP-120-NE	63
Front 1400	SP-140-AM	SP-140-NA	SP-140-RO	SP-140-BU	SP-140-AZ	SP-140-VE	SP-140-BL	SP-140-GR	SP-140-BE	SP-140-NE	68
Front 1600	SP-160-AM	SP-160-NA	SP-160-RO	SP-160-BU	SP-160-AZ	SP-160-VE	SP-160-BL	SP-160-GR	SP-160-BE	SP-160-NE	73
Front 1800	SP-180-AM	SP-180-NA	SP-180-RO	SP-180-BU	SP-180-AZ	SP-180-VE	SP-180-BL	SP-180-GR	SP-180-BE	SP-180-NE	79
Front 2000	SP-200-AM	SP-200-NA	SP-200-RO	SP-200-BU	SP-200-AZ	SP-200-VE	SP-200-BL	SP-200-GR	SP-200-BE	SP-200-NE	91
Front 2250	SP-225-AM	SP-225-NA	SP-225-RO	SP-225-BU	SP-225-AZ	SP-225-VE	SP-225-BL	SP-225-GR	SP-225-BE	SP-225-NE	99
Ang. open 45°	SPAA-45-AM	SPAA-45-NA	SPAA-45-RO	SPAA-45-BU	SPAA-45-AZ	SPAA-45-VE	SPAA-45-BL	SPAA-45-GR	SPAA-45-BE	SPAA-45-NE	55
Ang. closed 45°	SPAC-45-AM	SPAC-45-NA	SPAC-45-RO	SPAC-45-BU	SPAC-45-AZ	SPAC-45-VE	SPAC-45-BL	SPAC-45-GR	SPAC-45-BE	SPAC-45-NE	50
Ang. open 90°	SPAA-90-AM	SPAA-90-NA	SPAA-90-RO	SPAA-90-BU	SPAA-90-AZ	SPAA-90-VE	SPAA-90-BL	SPAA-90-GR	SPAA-90-BE	SPAA-90-NE	63
Ang. closed 90°	SPAC-90-AM	SPAC-90-NA	SPAC-90-RO	SPAC-90-BU	SPAC-90-AZ	SPAC-90-VE	SPAC-90-BL	SPAC-90-GR	SPAC-90-BE	SPAC-90-NE	57
Cold island 1600	SPIF-160-AM	SPIF-160-NA	SPIF-160-RO	SPIF-160-BU	SPIF-160-AZ	SPIF-160-VE	SPIF-160-BL	SPIF-160-GR	SPIF-160-BE	SPIF-160-NE	146
Cold island 2000	SPIF-200-AM	SPIF-200-NA	SPIF-200-RO	SPIF-200-BU	SPIF-200-AZ	SPIF-200-VE	SPIF-200-BL	SPIF-200-GR	SPIF-200-BE	SPIF-200-NE	182
Cold island 2250	SPIF-225-AM	SPIF-225-NA	SPIF-225-RO	SPIF-225-BU	SPIF-225-AZ	SPIF-225-VE	SPIF-225-BL	SPIF-225-GR	SPIF-225-BE	SPIF-225-NE	198
Hot island 1600	SPIC-160-AM	SPIC-160-NA	SPIC-160-RO	SPIC-160-BU	SPIC-160-AZ	SPIC-160-VE	SPIC-160-BL	SPIC-160-GR	SPIC-160-BE	SPIC-160-NE	146
Hot island 2000	SPIC-200-AM	SPIC-200-NA	SPIC-200-RO	SPIC-200-BU	SPIC-200-AZ	SPIC-200-VE	SPIC-200-BL	SPIC-200-GR	SPIC-200-BE	SPIC-200-NE	182
Hot island 2250	SPIC-225-AM	SPIC-225-NA	SPIC-225-RO	SPIC-225-BU	SPIC-225-AZ	SPIC-225-VE	SPIC-225-BL	SPIC-225-GR	SPIC-225-BE	SPIC-225-NE	198

Note: For children Self-service, substitute the first letter "SP" with "SIP"

WOOD-EFFECT PANELS



TYPE	WENGUE	WALNUT	BEECH	RRP (€)
Frontal 400	SP-40-WE	SP-40-NO	SP-40-HA	118
Frontal 600	SP-60-WE	SP-60-NO	SP-60-HA	127
Frontal 800	SP-80-WE	SP-80-NO	SP-80-HA	135
Frontal 1000	SP-100-WE	SP-100-NO	SP-100-HA	142
Frontal 1200	SP-120-WE	SP-120-NO	SP-120-HA	154
Frontal 1400	SP-140-WE	SP-140-NO	SP-140-HA	167
Frontal 1600	SP-160-WE	SP-160-NO	SP-160-HA	179
Frontal 1800	SP-180-WE	SP-180-NO	SP-180-HA	194
Frontal 2000	SP-200-WE	SP-200-NO	SP-200-HA	223
Frontal 2250	SP-225-WE	SP-225-NO	SP-225-HA	244
Ang. abierto 45°	SPAA-45-WE	SPAA-45-NO	SPAA-45-HA	135
Ang. cerrado 45°	SPAC-45-WE	SPAC-45-NO	SPAC-45-HA	122
Ang. abierto 90°	SPAA-90-WE	SPAA-90-NO	SPAA-90-HA	154
Ang. cerrado 90°	SPAC-90-WE	SPAC-90-NO	SPAC-90-HA	140
Cold island 1600	SPIF-160-WE	SPIF-160-NO	SPIF-160-HA	358
Cold island 2000	SPIF-200-WE	SPIF-200-NO	SPIF-200-HA	446
Cold island 2250	SPIF-225-WE	SPIF-225-NO	SPIF-225-HA	492
Hot island 1600	SPIC-160-WE	SPIC-160-NO	SPIC-160-HA	358
Hot island 2000	SPIC-200-WE	SPIC-200-NO	SPIC-200-HA	446
Hot island 2250	SPIC-225-WE	SPIC-225-NO	SPIC-225-HA	492

Note: For children Self-service, substitute the first letter "SP" with "SIP"



- Optionally, the panels can be manufactured in any colour and with personalized decoration on vinyl film (inquire about prices)

NEW

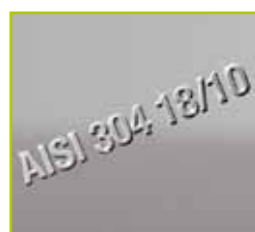

Maximum quality
Premium quality stainless steel AISI 304/10 products equipped with materials of European leading brands, designed for a professional and long-lasting use.



Designed for children
Especially designed for the catering of food and drink to children of different ages, normally between 6 and 12 years old. Some design characteristics are present only in this range.



Security
Children Self-service includes special characteristics to offer a total security for children. Among them, it includes the bain-marie module 90°, which prevents risks of burns.



Hygiene and ergonomics
All materials used, together with the ample sanitary edges applied to the surfaces, ensure extreme hygiene. All elements have been designed complying with ergonomics and enabling an easy use.



Personalization and product range
The children range self-service offers a great variety of modules and accessories. The decorative panels can be customized in plain colour, wood effect or any desired design.



Easy installation
The constructive modular system composed by independent equipment sets simplifies the installation of the Self-service. Its accessories have been designed to be quickly and easily installed.



Efficiency and technology
Cooled and hot Self-service modules are highly efficient thanks to the engineering applied to its technical design and the use of coolant gasses and insulation of leading-edge technology.



Finish and design
The finish and design details are top range. Metal hardware, tempered glass, hanging doors, perfect adjustments. No welds, rivets, plastic or rails at sight.

CHILDREN OPEN SELF COOLED BOARD



- Manufactured of satin 304 18/10 stainless steel.
- Built-in countertop, with 80mm fronts, and entirely welded.
- Cooled board with high density ecologic insulation.
- Open lower part.
- Refrigerated by means of copper serpentine tubing, condense gas unit R-290 and thermostat digital control.
- Condenser unit removable by means of rails, which makes its maintenance and cleanness easy.
- Board interval temperature $-4^{\circ}\text{C}/+4^{\circ}\text{C}$.
- Incorporated drainage.
- Robust height adjustable legs by means of hidden screw, with optional decorative plinths, see page 195.
- Single-phase voltage 230v/50Hz.
- Stainless steel front decorative panel. Optionally, it can be supplied in plain colours or wood-effect; see page 196.
- Optional gas R-134a.



Detail of cooled board.

Model	Dimensions	Capacity	Power (W)	RRP (€)
SIPFA-80/R	800x700x720	2GN	210	2.101
SIPFA-120/R	1200x700x720	3GN	350	2.222
SIPFA-160/R	1600x700x720	4GN	350	2.354

CHILDREN OPEN COOLED WELL



- Manufactured of satin 304 18/10 stainless steel.
- Built-in countertop, with 60mm fronts, and entirely welded.
- Cooled well with rounded sanitary edges and capacity for GN wells maximum 200mm deep.
- Refrigerated by means of copper serpentine tubing, condense gas unit R-290 and thermostat digital control.
- Condenser unit removable by means of rails, which makes its maintenance and cleanness easy.
- Board interval temperature $0^{\circ}\text{C}/-5^{\circ}\text{C}$.
- Incorporated drainage.
- Robust height adjustable legs by means of hidden screw, with optional decorative plinths, see page 195.
- Single-phase voltage 230v/50Hz
- Stainless steel front decorative panel. Optionally, it can be supplied in plain colours or wood-effect; see page 196
- Optional gas R-134a.



Model	Dimensions	Capacity	Power (W)	RRP (€)
SICFA-80/R	800x700x720	2GN-200	210	2.141
SICFA-120/R	1200x700x720	3GN-200	350	2.262
SICFA-160/R	1600x700x720	4GN-200	350	2.545

Lamp strip or trays slides are not included in the price. See page 193-194

COOLED SHOWCASE KIT WITH INSULATED BASE AND CHILDREN SELF COUNTER

- Manufactured of satin 304 18/10 stainless steel.
- Cabinet countertop with front edges 80mm, entirely welded.
- Embedded lower base with rounded corners for a better hygiene and easy to clean which includes ecologic high density and thickness insulation.
- Double glazing sliding doors on the service side and methacrylate hinged doors on the clients' side.
- Refrigerated by means of ventilated evaporator, condenser unit with gas R-290 and thermostat digital control.
- Neutral inferior module.
- Robust height adjustable legs by means of hidden screw, with optional decorative plinths, see page 195.
- Stainless steel front decorative panel. Optionally, it can be supplied in plain colours or wood-effect; see page 196
- Single-phase voltage 230v/50Hz
- Working temperature interval in the well+ $4^{\circ}\text{C}/+12^{\circ}\text{C}$.
- Built-in drainage.
- Removable glass shelves.
- Low consumption interior illumination.
- Optional gas R-134a.



Model	Dimensions	Capacity	Power (W)	RRP (€)
SIVPN-160/R	1600x700x1725	4GN	1100	5.096



COOLED SHOWCASE KIT WITH INSULATED WELL AND CHILDREN SELF COUNTER

- Manufactured of satin 304 18/10 stainless steel.
- Cabinet countertop with front edges 80mm, entirely welded.
- Embedded well with rounded sanitary edges and capacity for GN wells maximum 200mm deep which includes ecologic high density and thickness insulation.
- Double glazing sliding doors on the service side and methacrylate hinged doors on the clients' side.
- Refrigerated by means of ventilated evaporator, condenser unit with gas R-290 and thermostat digital control.
- Robust height adjustable legs by means of hidden screw, with optional decorative plinths, see page 195.
- Stainless steel front decorative panel. Optionally, it can be supplied in plain colours or wood-effect; see page 196
- Single-phase voltage 230v/50Hz
- Working temperature interval in the well+ $4^{\circ}\text{C}/+12^{\circ}\text{C}$.
- Built-in drainage.
- Removable glass shelves.
- Low consumption interior illumination.
- Optional gas R-134a.



Model	Dimensions	Capacity	Power (W)	RRP (€)
SIVCN-160/R	1600x700x1725	4GN	1100	5.288



CHILDREN SELF HUMID BEIN-MARIE



- Manufactured of satin 304 18/10 stainless steel.
- Heated well with rounded sanitary edges and capacity for wells GN maximum 200mm deep.
- Fireproof ecologic polyurethane insulation.
- Well heating by means of silicone resistances that improve the efficiency and reduce the electric consumption.
- Adjustable well temperature +30°C/+90°C.
- Inlet tap of and drainage of 1/2" with ball valve mechanism and overflow pipe.
- Countertop with front edges 80mm, entirely welded.
- Robust height adjustable legs by means of hidden screw, with optional decorative plinths, see page 195.
- Stainless steel front decorative panel. Optionally, it can be supplied in plain colours or wood-effect; see page 196
- Single-phase voltage 230v/50Hz.

OPEN HUMID BEIN-MARIE

Model	Dimensions	Capacity	Power (W)	RRP (€)
SIBMA-80	800x700x850	2GN-200	1500	1.766
SIBMA-120	1200x700x850	3GN-200	2000	1.968
SIBMA-160	1600x700x850	4GN-200	3000	2.300

HUMID BEIN-MARIE WITH NEUTRAL RESERVE

- Suspended sliding doors of smooth slide by means of rail with ball bearing.

Model	Dimensions	Capacity	Power (W)	RRP (€)
SIBMN-120	1200x700x850	3GN-200	2000	2.392
SIBMN-160	1600x700x850	4GN-200	3000	2.787

HUMID BEIN-MARIE WITH HEATED RESERVE

- Interior heating by removable ventilated resistances with security thermal klixon.
- Double wall and glass fibre integral insulation, in the case as well as the doors.
- Additional control panel with digital thermometer/thermostat and illuminated switch. Adjustable temperature +30°C/+75°C.
- Suspended sliding doors of smooth slide.

Model	Dimensions	Capacity	Power (W)	RRP (€)
SIBMR-120	1200x700x850	3GN-200	4100	2.570
SIBMR-160	1600x700x850	4GN-200	5100	2.907

Lamp strip, glass or trays slides are not included in the price, see page 193-194. GN trays are not included, see page 141.

CHILDREN SELF DRY BEIN-MARIE



- Manufactured of satin 304 18/10 stainless steel.
- Well with rounded sanitary edges and capacity for wells GN maximum 150mm deep.
- Fireproof ecologic polyurethane insulation.
- Well heating by means of shielded resistances protected by drilled double bottom.
- Removable resistances to facilitate its cleanness.
- Adjustable well temperature +30°C/+90°C.
- Countertop with front edges 80mm, entirely welded.
- Robust height adjustable legs by means of hidden screw, with optional decorative plinths, see page 195.
- Stainless steel front decorative panel. Optionally, it can be supplied in plain colours or wood-effect; see page 196
- Single-phase voltage 230v/50Hz.

OPEN DRY BEIN-MARIE

Model	Dimensions	Capacity	Power (W)	RRP (€)
SIBSA-80	800x700x850	2GN-150	1750	1.700
SIBSA-120	1200x700x850	3GN-150	1750	1.902
SIBSA-160	1600x700x850	4GN-150	2500	2.234

DRY BEIN-MARIE WITH NEUTRAL RESERVE

- Suspended sliding doors of smooth slide by means of rail with ball bearing.

Model	Dimensions	Capacity	Power (W)	RRP (€)
SIBSN-120	1200x700x850	3GN-150	1750	2.327
SIBSN-160	1600x700x850	4GN-150	2500	2.722

DRY BEIN-MARIE WITH HEATED RESERVE

- Interior heating by removable ventilated resistances with security thermal klixon.
- Double wall and glass fibre integral insulation, in the case as well as the doors.
- Additional control panel with digital thermometer/thermostat and illuminated switch. Adjustable temperature +30°C/+75°C.
- Suspended sliding doors of smooth slide.

Model	Dimensions	Capacity	Power (W)	RRP (€)
SIBSR-120	1200x700x850	3GN-150	3850	2.505
SIBSR-160	1600x700x850	4GN-150	4600	2.841

Lamp strip, glass or trays slides are not included in the price, see page 193-194. GN trays are not included, see page 141.

CHILDREN SELF GLASS-CERAMIC MODULES



Lamp strip, glass panel and trays slide not included

- Manufactured of satin 304 18/10 stainless steel.
- Glass-ceramic SCHOTT CERAN® 6mm thick.
- Heating by silicone resistances adjustable by means of thermostat with security thermal klixon.
- Adjustable well temperature +30°C/+90°C.
- Countertop with front edges 80mm, entirely welded.
- Robust height adjustable legs by means of hidden screw, with optional decorative plinths, see page 195.
- Stainless steel front decorative panel. Optionally, it can be supplied in plain colours or wood-effect; see page 196.
- Single-phase voltage 230v/50Hz.



OPEN GLASS-CERAMIC

Model	Dimensions	Capacity	Power (W)	RRP (€)
SIVTA-80	800x700x850	2GN	1500	1.987
SIVTA-120	1200x700x850	3GN	1650	2.293
SIVTA-160	1600x700x850	4GN	2200	2.784



GLASS-CERAMIC WITH NEUTRAL RESERVE

- Suspended sliding doors of smooth slide by means of guide rails with ball bearings.

Model	Dimensions	Capacity	Power (W)	RRP (€)
SIVTN-120	1200x700x850	3GN	1650	2.717
SIVTN-160	1600x700x850	4GN	2200	3.272



GLASS-CERAMIC WITH HEATED RESERVE

- Interior heating by removable ventilated resistances.
- Double wall and glass fibre integral insulation.
- Additional control panel with digital thermostat.
- Adjustable temperature +30°C/+90°C.
- Suspended sliding doors of smooth slide.

Model	Dimensions	Capacity	Power (W)	RRP (€)
SIVTR-120	1200x700x850	3GN	3750	2.895
SIVTR-160	1600x700x850	4GN	4300	3.391

CHILDREN SELF NEUTRAL MODULES

- Manufactured of satin 304 18/10 stainless steel.
- Countertop with front edges 80mm, entirely welded.
- Robust height adjustable legs by means of hidden screw, with optional decorative plinths, see page 195.
- Stainless steel front decorative panel. Optionally, it can be supplied in plain colours or wood-effect; see page 196.



Lamp strip, glass panel and trays slide not included

OPEN NEUTRAL MODULES

Model	Dimensions	RRP (€)
SINA-80	800x700x720	861
SINA-120	1200x700x720	1.073
SINA-140	1400x700x720	1.177
SINA-160	1600x700x720	1.243

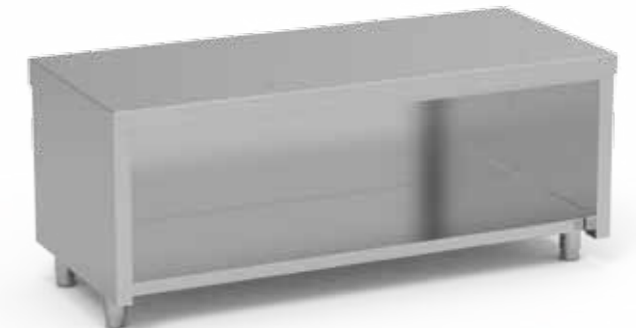

NEUTRAL ELEMENT FOR HEATED MODULES SERVICE

- Specially designed for the security of children during hot food catering (glass ceramic, bain-marie).
- The food kept in heated modules is served on plates and handed in to children on the trays slide element.
- This module should be installed joining 90° onto the selected heated. For a correct joint, the correspondent hardware is supplied; see example of application.
- Manufactured of satin 304 18/10 stainless steel.
- Countertop with front edges 80mm, entirely welded and reinforced by means of omegas.
- Robust height adjustable legs by means of hidden screw, with optional decorative plinths, see page 195.
- Stainless steel front decorative panel. Optionally, it can be supplied in plain colours or wood-effect; see page 196.

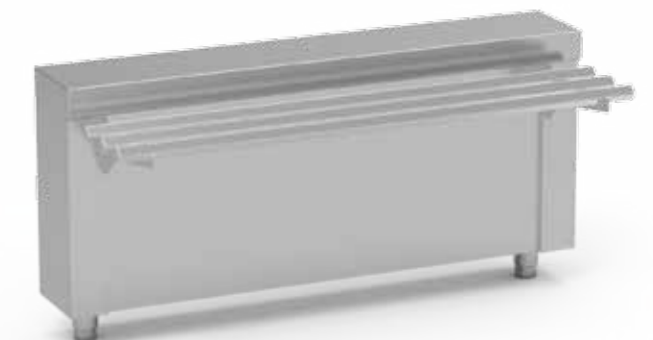
Example of setting:
SINF-140 + SDMR-160

Bain-marie module, lamp strip, GN wells are not included

Model	Dimensions	RRP (€)
SINF-140	1400x240x720	1.274

CHILDREN SELF ANGLED NEUTRAL MODULES

- Manufactured of satin 304 18/10 stainless steel.
- Countertop with front edges 80mm, entirely welded.
- Robust legs adjustable to mid-height by means of hidden screw, with optional decorative plinths, see page 161.
- Stainless steel front decorative panel. Optionally, it can be supplied in plain colours or wood-effect; see page 161.



CHILDREN SELF OPEN ANGLED MODULE 45°

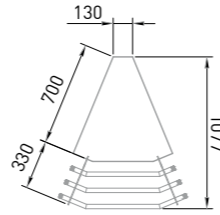

Model	Dimensions	RRP (€)
SIAA-45	665x700x720	857



CHILDREN SELF CLOSED ANGLED MODULE 45°

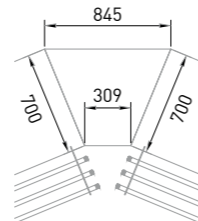

Model	Dimensions	RRP (€)
SIAC-45	845x650x720	920



CHILDREN SELF OPEN ANGLED MODULE 90°

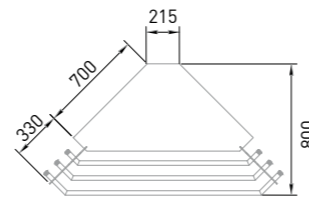

Model	Dimensions	RRP (€)
SIAA-90	1205x585x720	1.099



CHILDREN SELF CLOSED ANGLED MODULE 90°

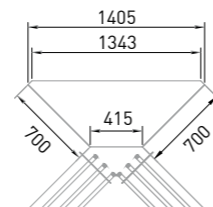

Model	Dimensions	RRP (€)
SIAC-90	1405x525x720	1.052

Trays slides are not included. See page 194.

COUNTERTOP BREAD SERVING UNIT

- Manufactured of satin 304 18/10 stainless steel.
- Model SIPNP includes plastic cutlery rack.
- Tube legs 40x60mm.
- Robust height adjustable legs by means of hidden screw.



Model	Dimensions	RRP (€)
SIPNP	720x700x1360	1.098



Model	Dimensions	RRP (€)
SIDVP	720x700x1475	1.219

BREAD SERVING UNIT AND CUTLERY RACK; BREAD, CUTLERY AND GLASSES SERVING UNITS



Model SPNS

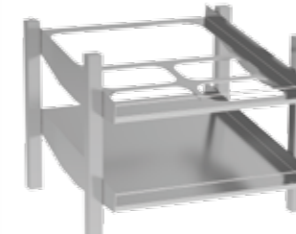

Model SDPS

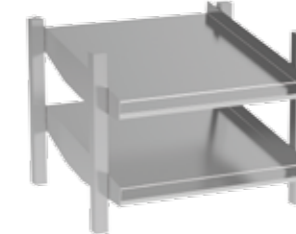

Model SDVS



SDPS + KCDP

- Manufactured of satin 304 18/10 stainless steel.
- Tube legs 40x60mm.
- Two possible clamping systems: Adjustable legs or bolted to the countertop, both included in series.
- In model SPNS, the upper tray includes shafts for 1 well GN1/1 and 4 wells GN 1/4 (the wells are not included, see stainless steel wells KCDP).

Model	Dispenser	Dimensions	RRP (€)
SPNS		710x700x500	526
SDPS	Bread, cutlery, glasses	715x690x665	636
SDVS	Glasses	715x690x665	762
KCDP	GN wells kit	1 GN 1/1 100 4 GN 1/4 100	107,5

TRAYS SLIDES, PLINTH, WHEELS, LAMP STRIP, GLASS PANELS AND DECORATIVE PANELS

- All the complements for children Self-service are the same as those for adults Self-service; see pages:
 - Trays slide, plinths and wheels, pages 194-195.
 - Lamp strips and glass panels, pages 193-194.
 - To order a decorative children Self-service panel, select the model equivalent to adults Self-service and change the reference on the initial letters "SP" to "SIP". See



