

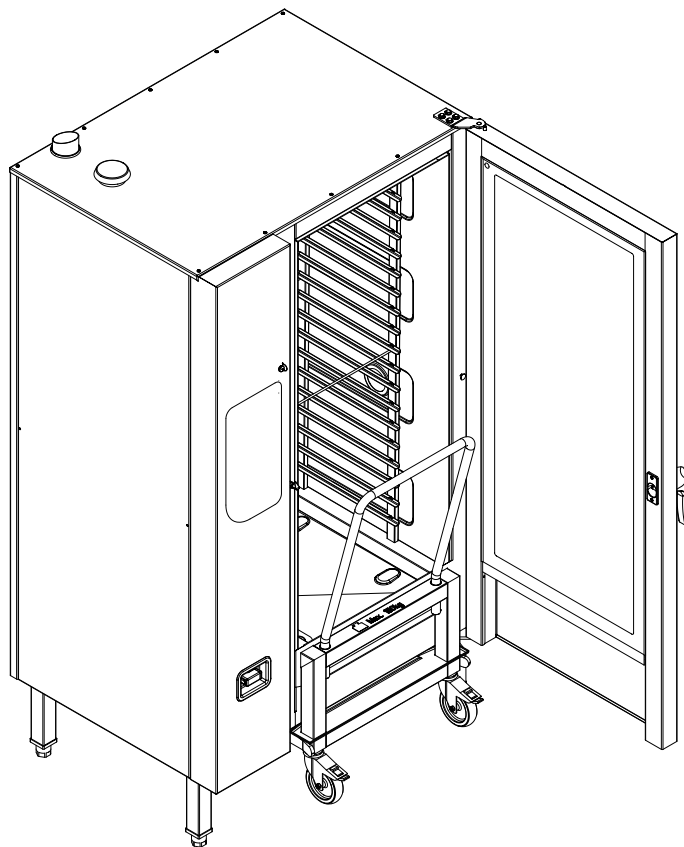

FlexiCombi MagicPilot & FlexiCombi Classic 221M



Appareil	Modèle	Type d'énergie	Type d'appareil
FlexiCombi MagicPilot	221 MAX	Électrique 3NPE400V AC	Appareil sur pied
FlexiCombi Classic		Gaz 1NPE230V AC	
Électrique à partir de S/N 19204376			
Gaz de S/N 1821702			

1 Panneau de commande MagicPilot	5
2 Panneau de commande Classic	6
3 Commande MagicPilot	7
4 Commande classique avec WaceClean	8
5 Commande classique sans WaceClean	9
6 Ensemble énergétique électrique 3NPE400V	10
7 Ensemble énergétique gaz 1NPE230V	11
8 Sonde de température à cœur	12
9 Sonde de température externe	13
10 Enrouleur de tuyau et douchette	14
11 Ensemble d'eau avec WaveClean 50Hz	15
12 Carter - chambre de cuisson 20.x Eletkro	16
13 Carter - chambre de cuisson 20.x Gaz	17
14 Carter - Porte du four électrique butée de droite	18
15 Carter - porte de la chambre de cuisson gaz butée de droite	19

1 Panneau de commande MagicPilot

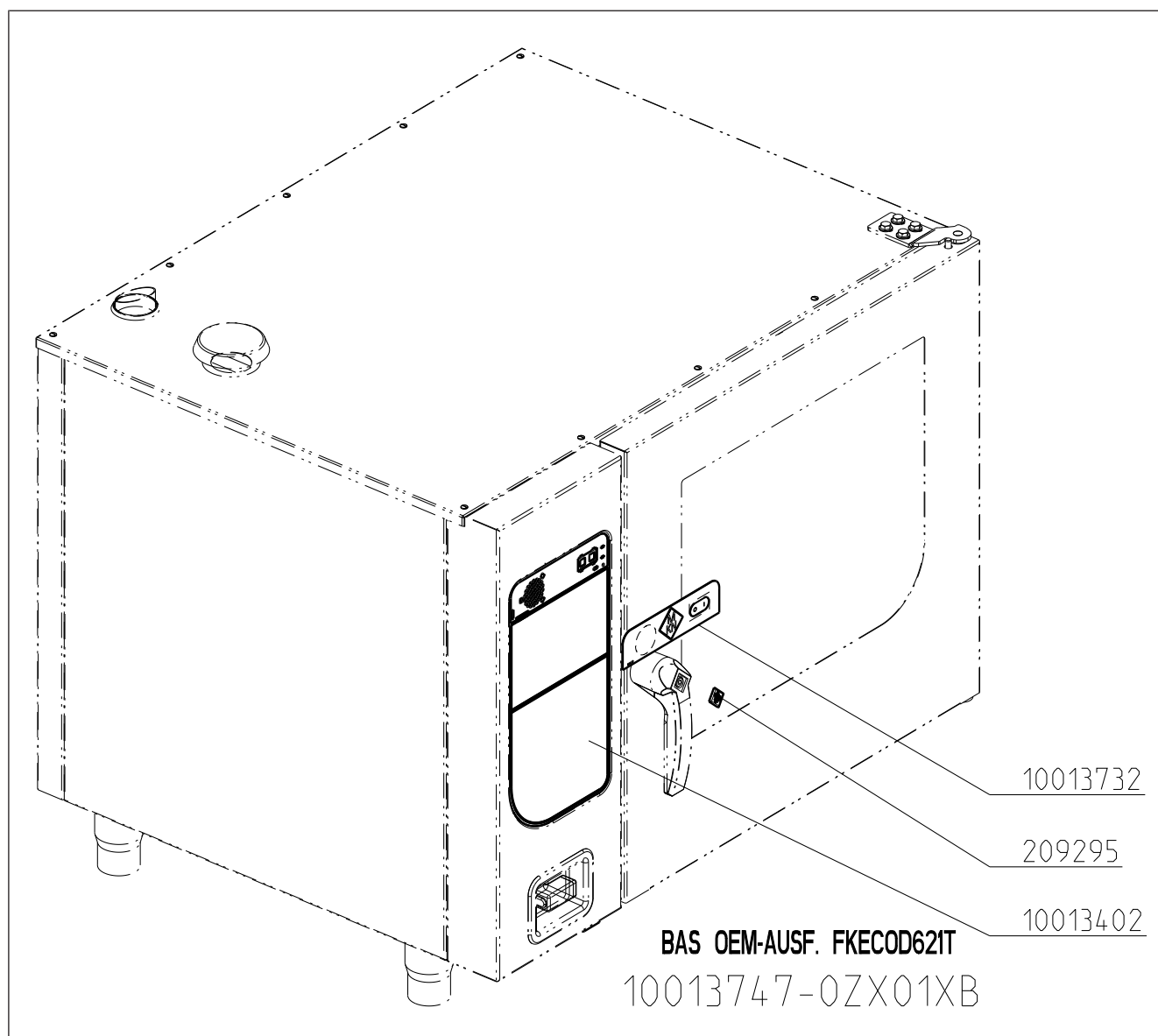

1000001199ZXFR-



2 Panneau de commande Classic

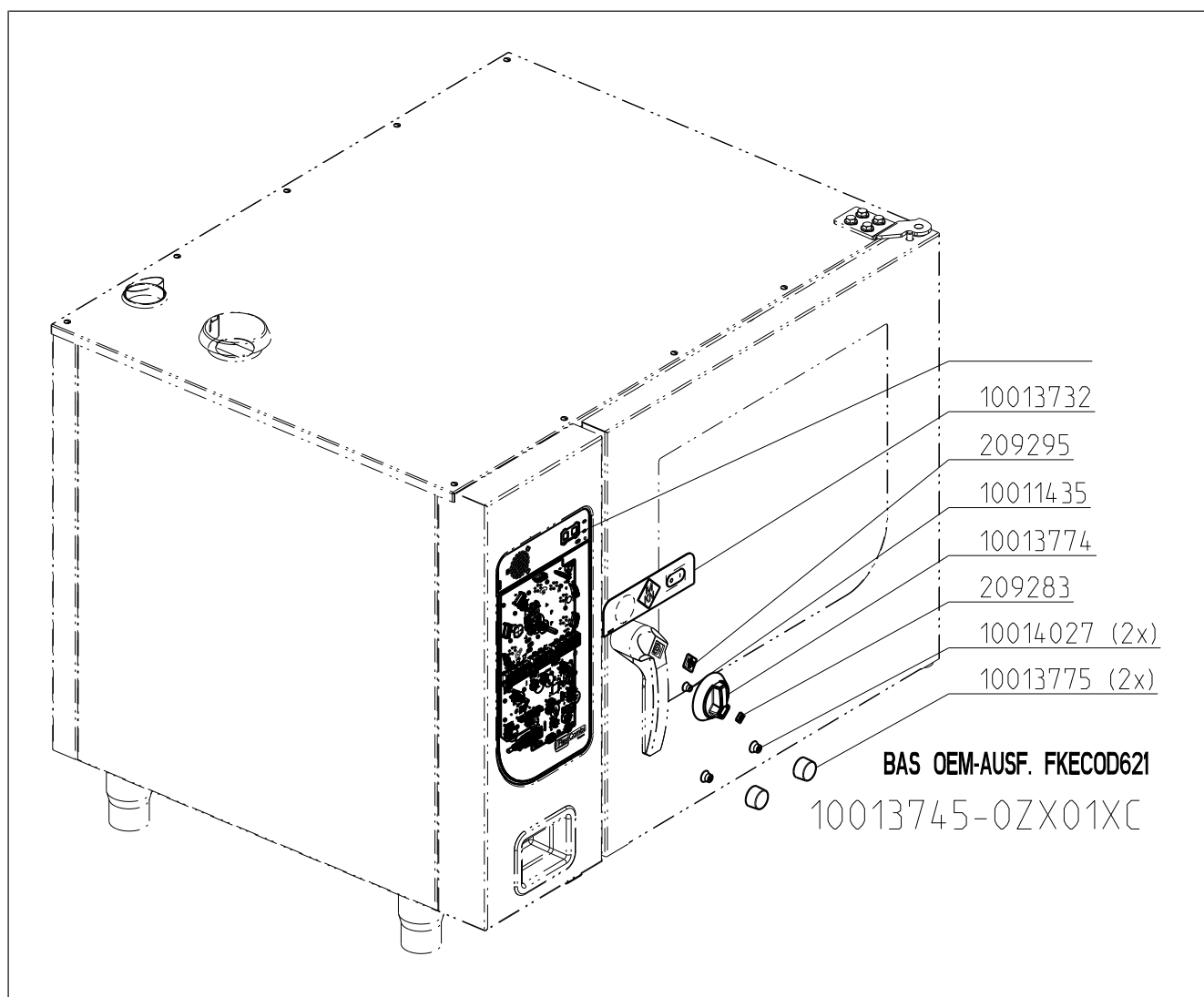

3 Comande MagicPilot

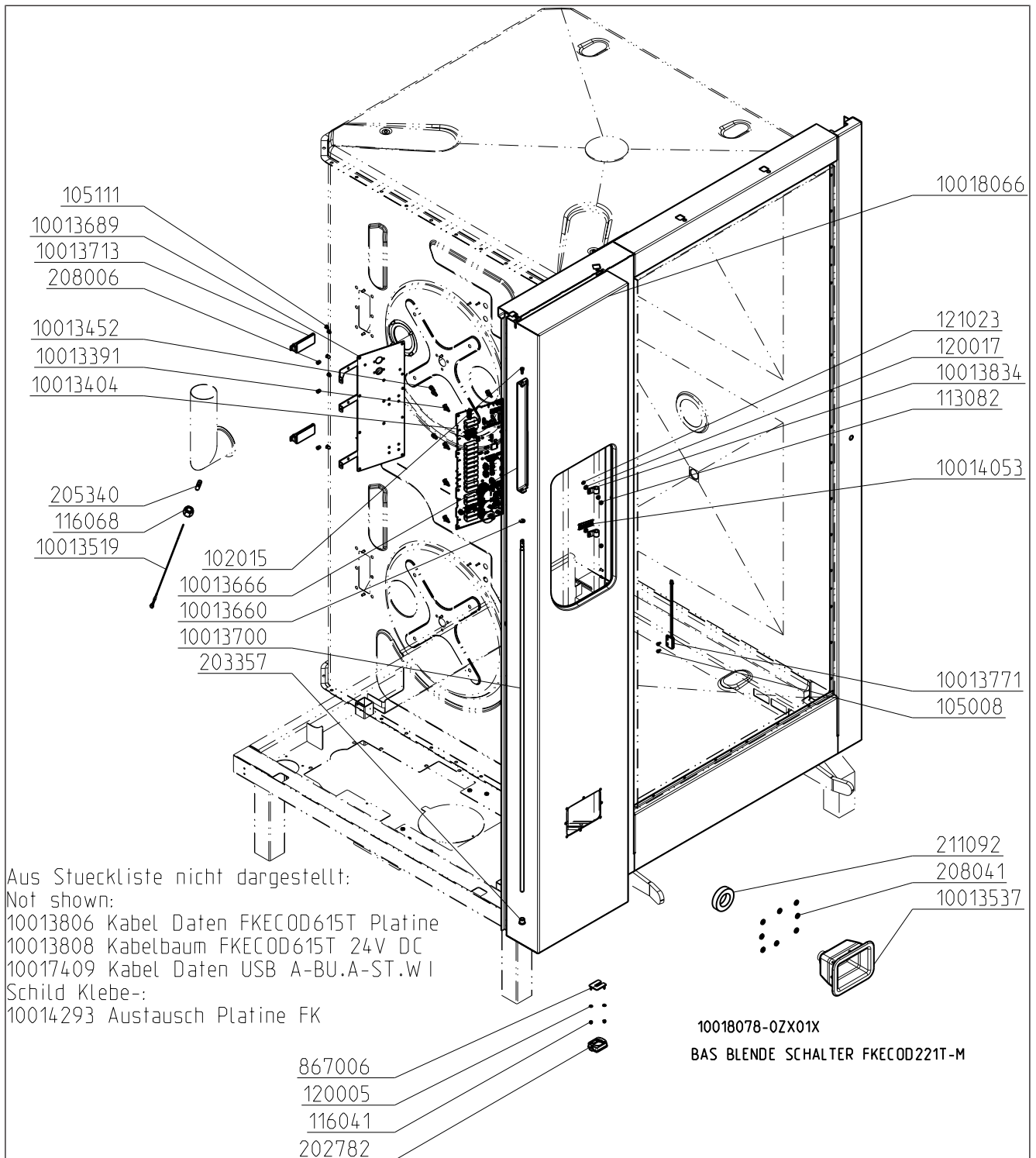

4 Commande classique avec WaceClean

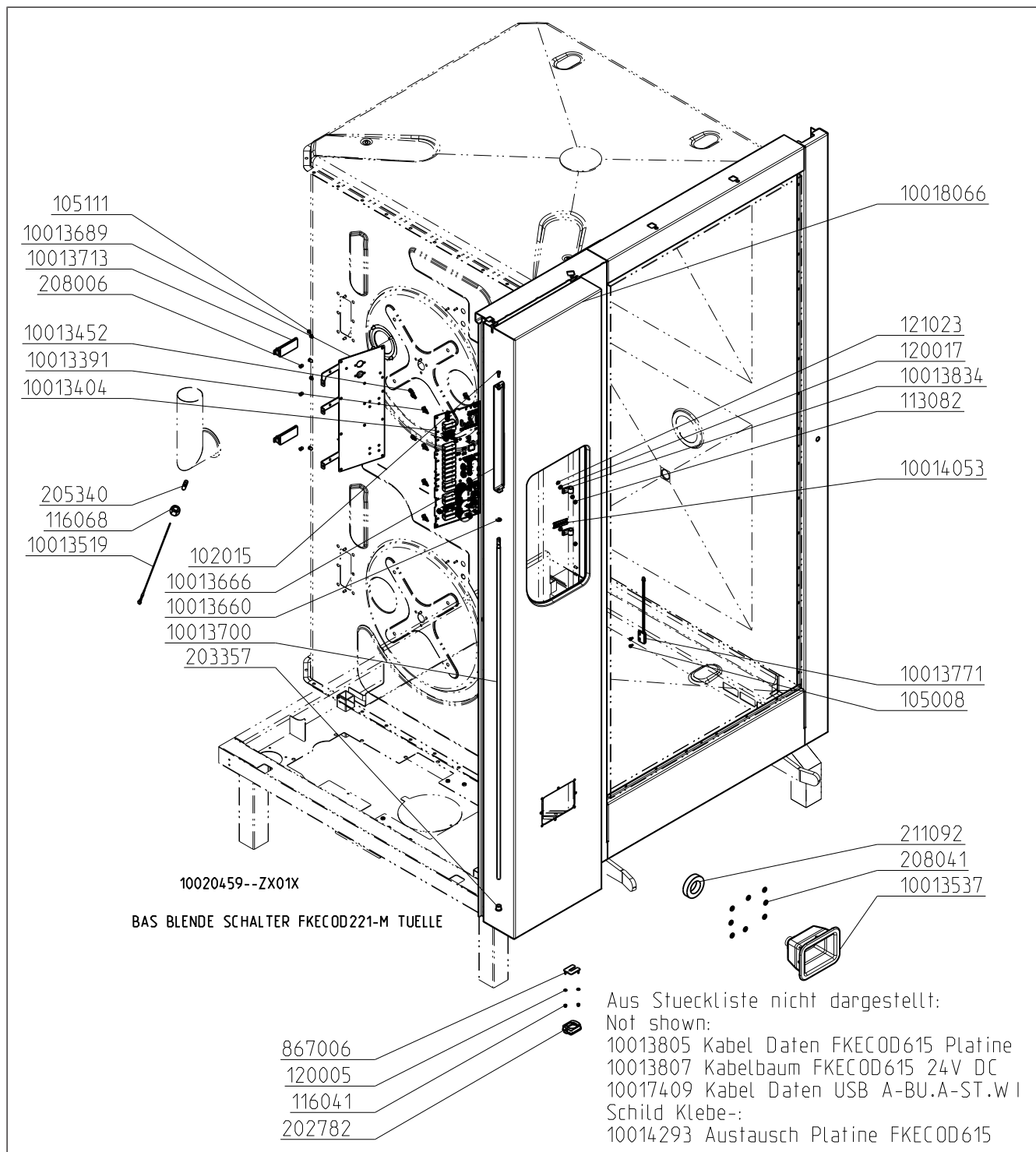

5 Commande classique sans WaceClean

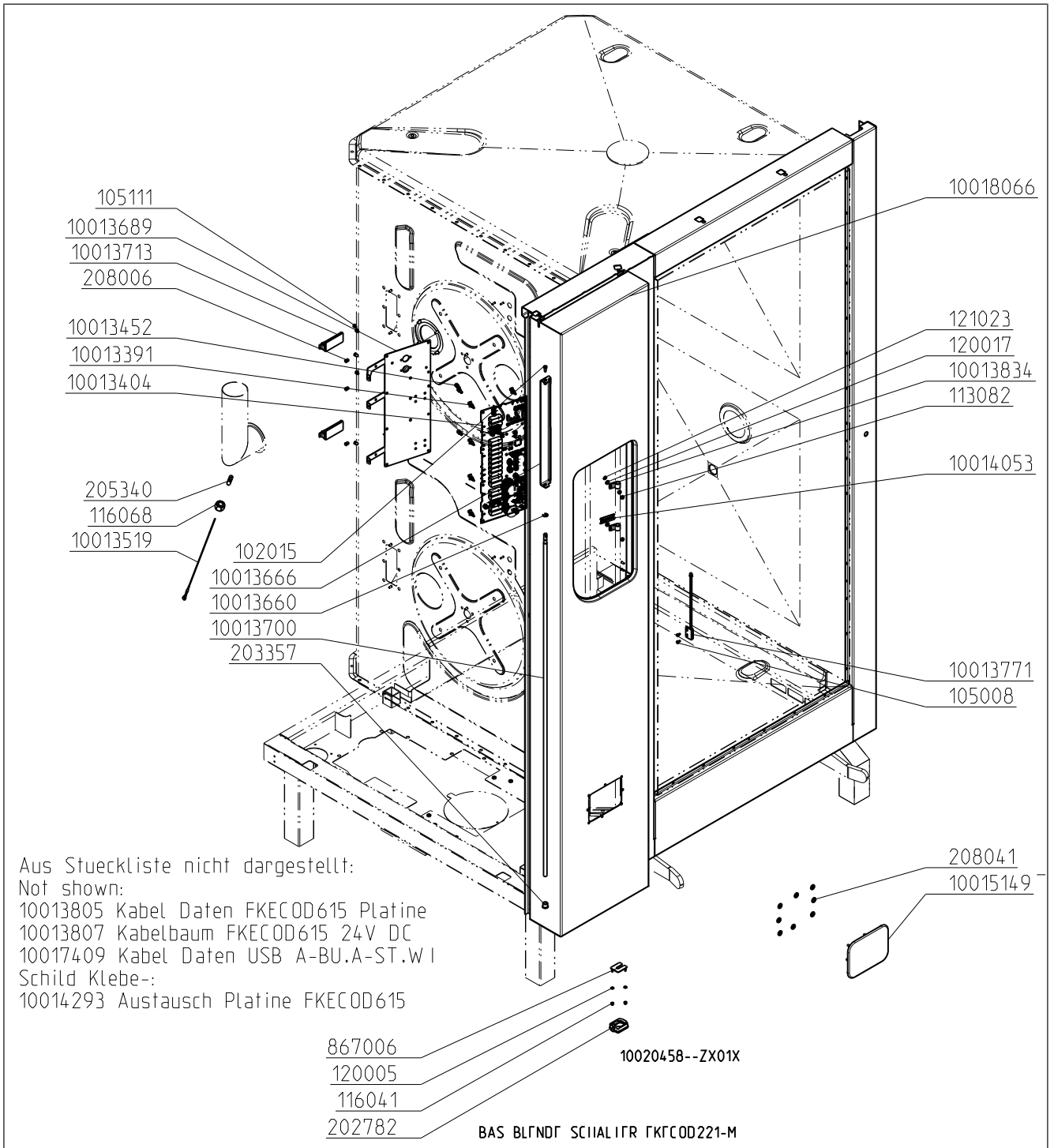

7 Ensemble énergétique gaz 1NPE230V

10000011199ZXR-

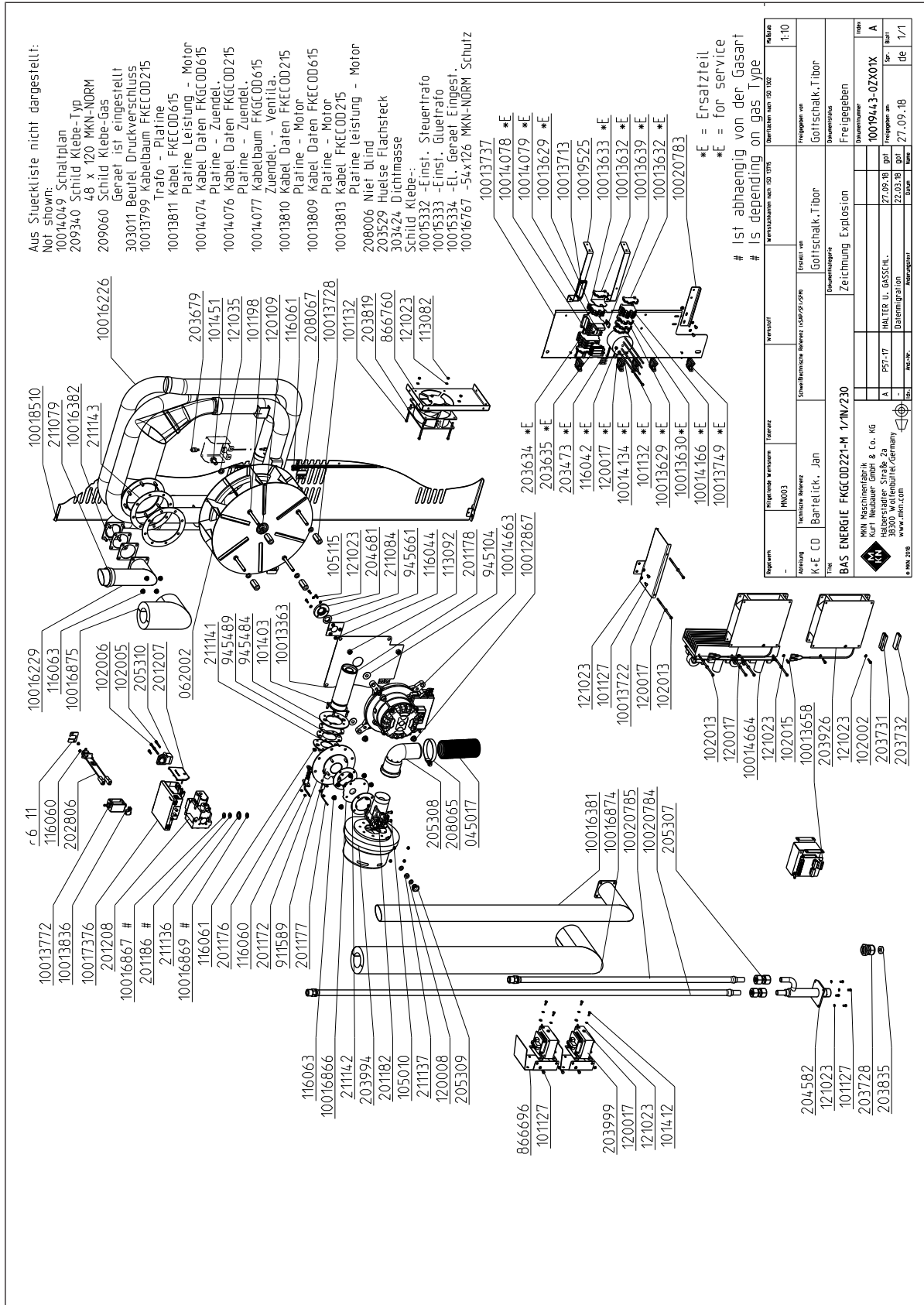

8 Sonde de température à cœur

10013516: Einpunktfühler - single point probe (nur/only Classic)

10013579: Mehrpunktfühler - multi point probe (MagicPilot, option bei/at Classic)

121210

BAS FUEHLER FKECOD215
1001357 -OZX01X-

9 Sonde de température externe

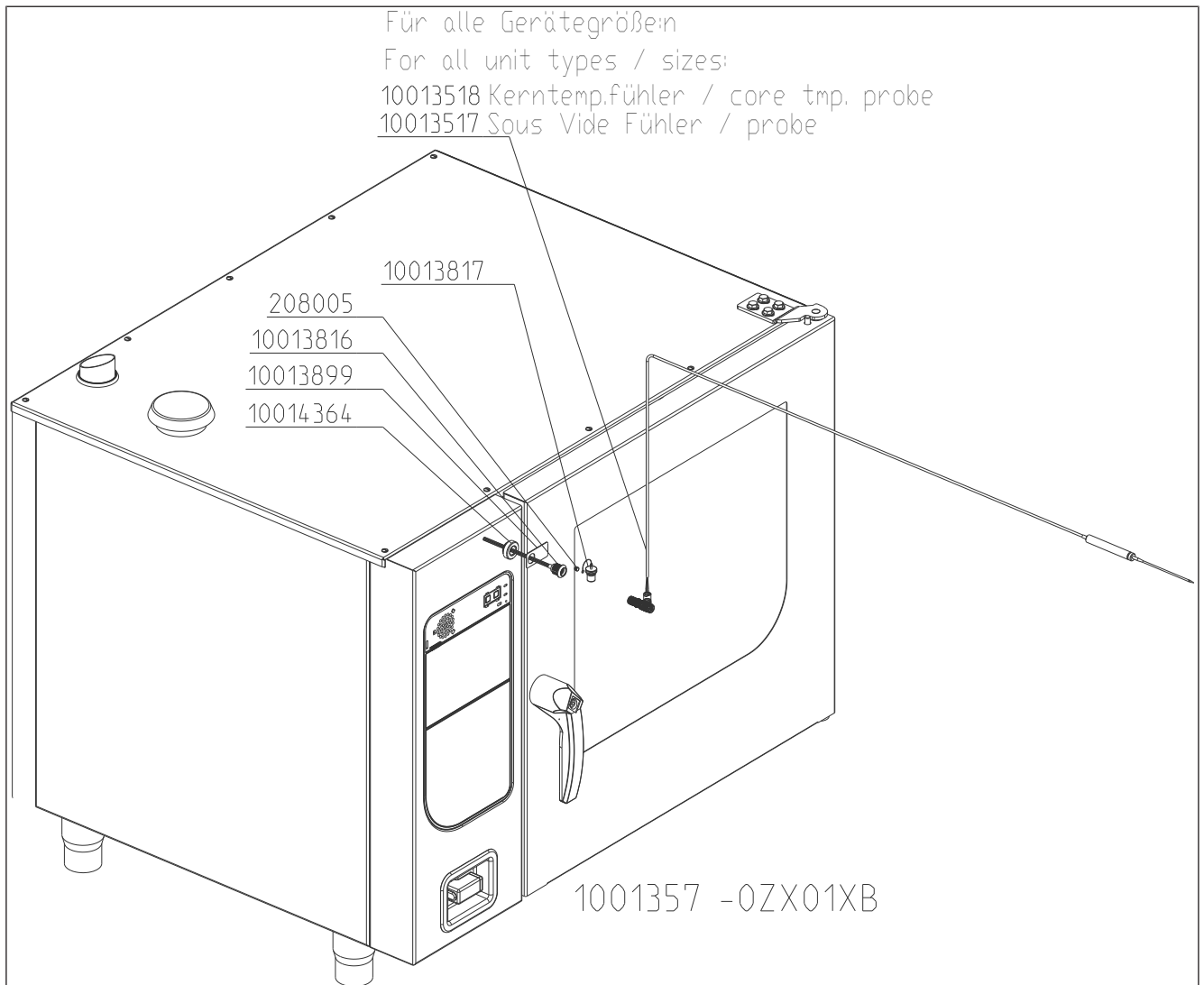

10 Enrouleur de tuyau et douchette

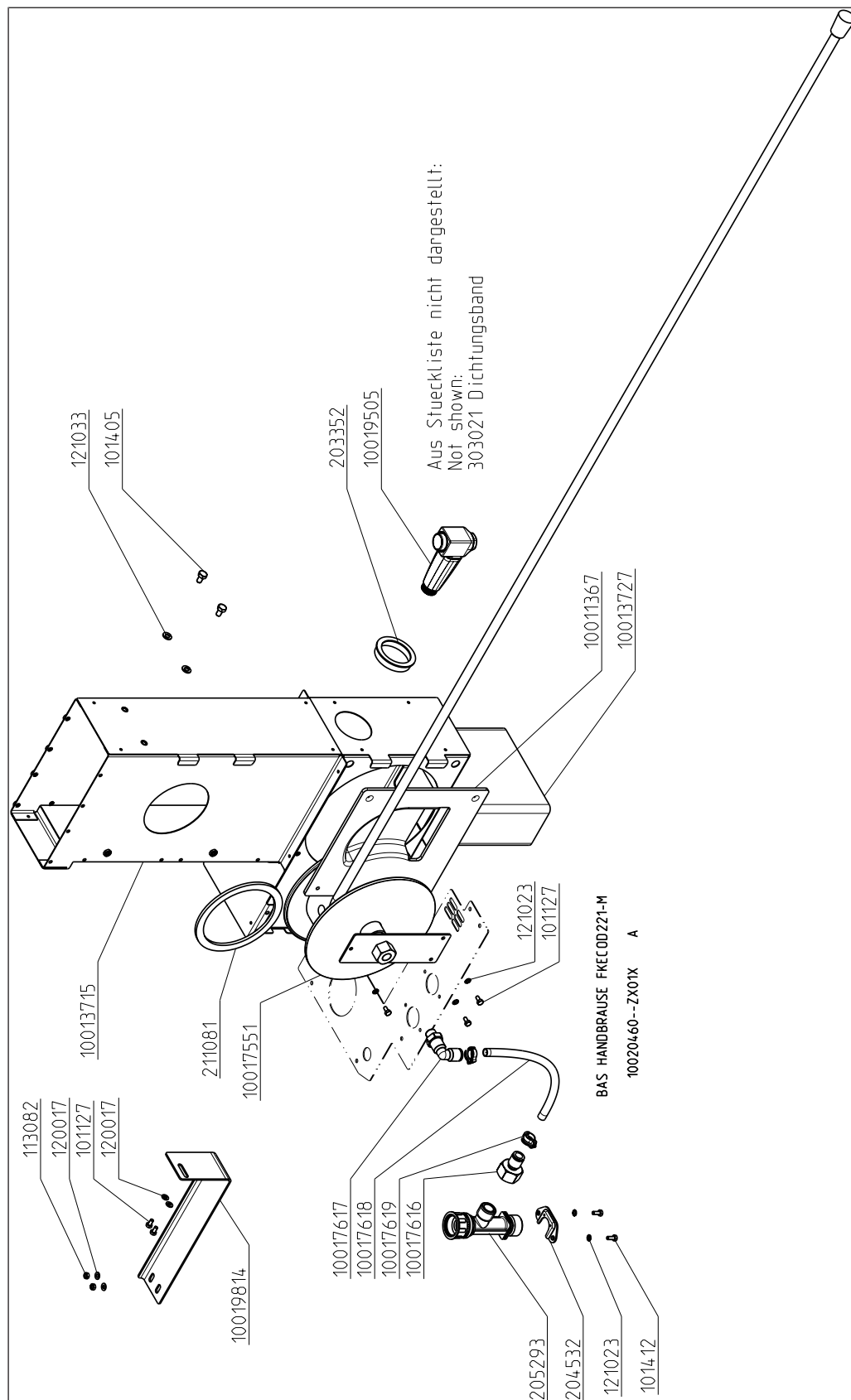

11 Ensemble d'eau avec WaveClean 50Hz

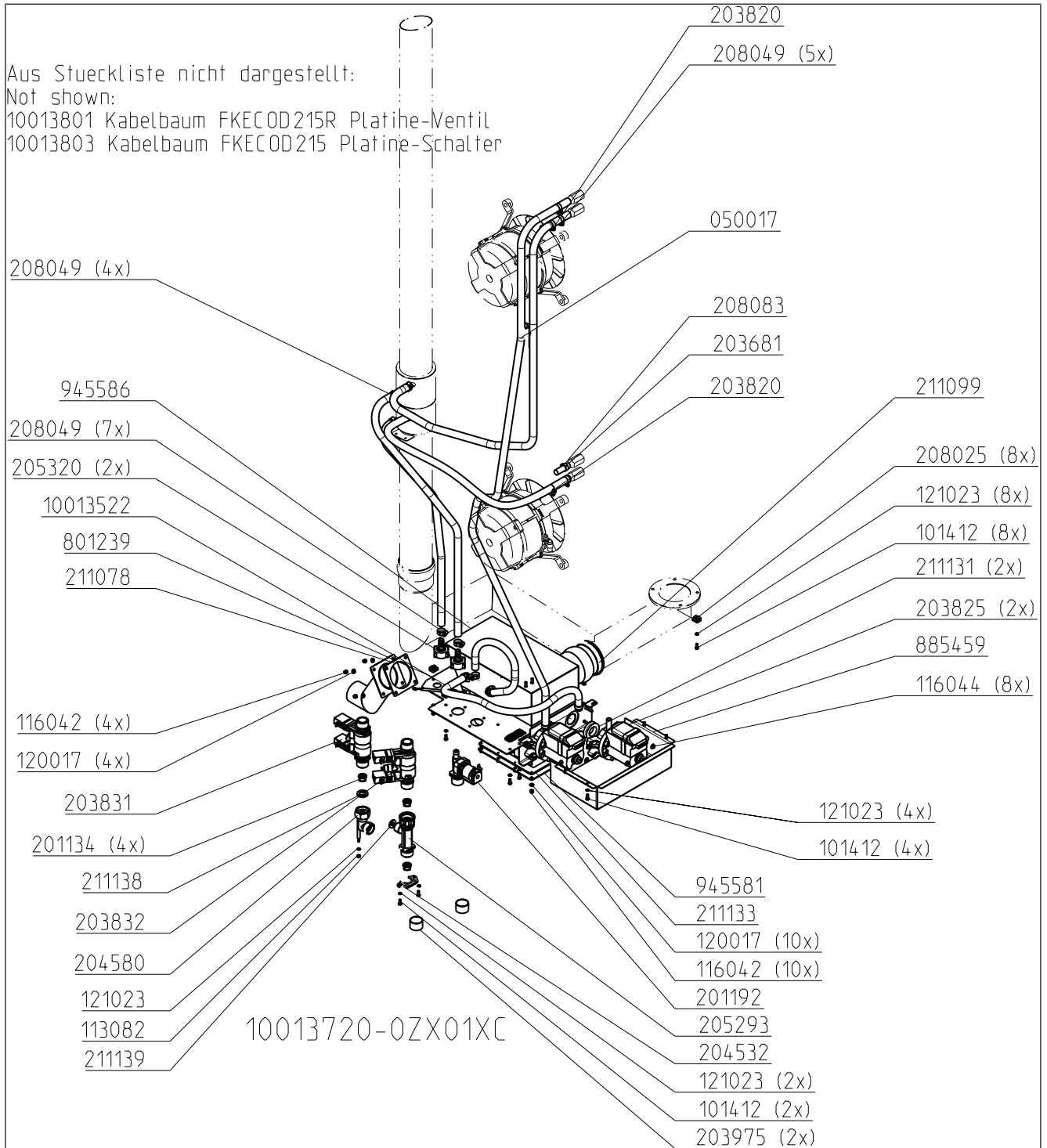

1000001199ZXFR-



12 Carter - chambre de cuisson 20.x Eletkro

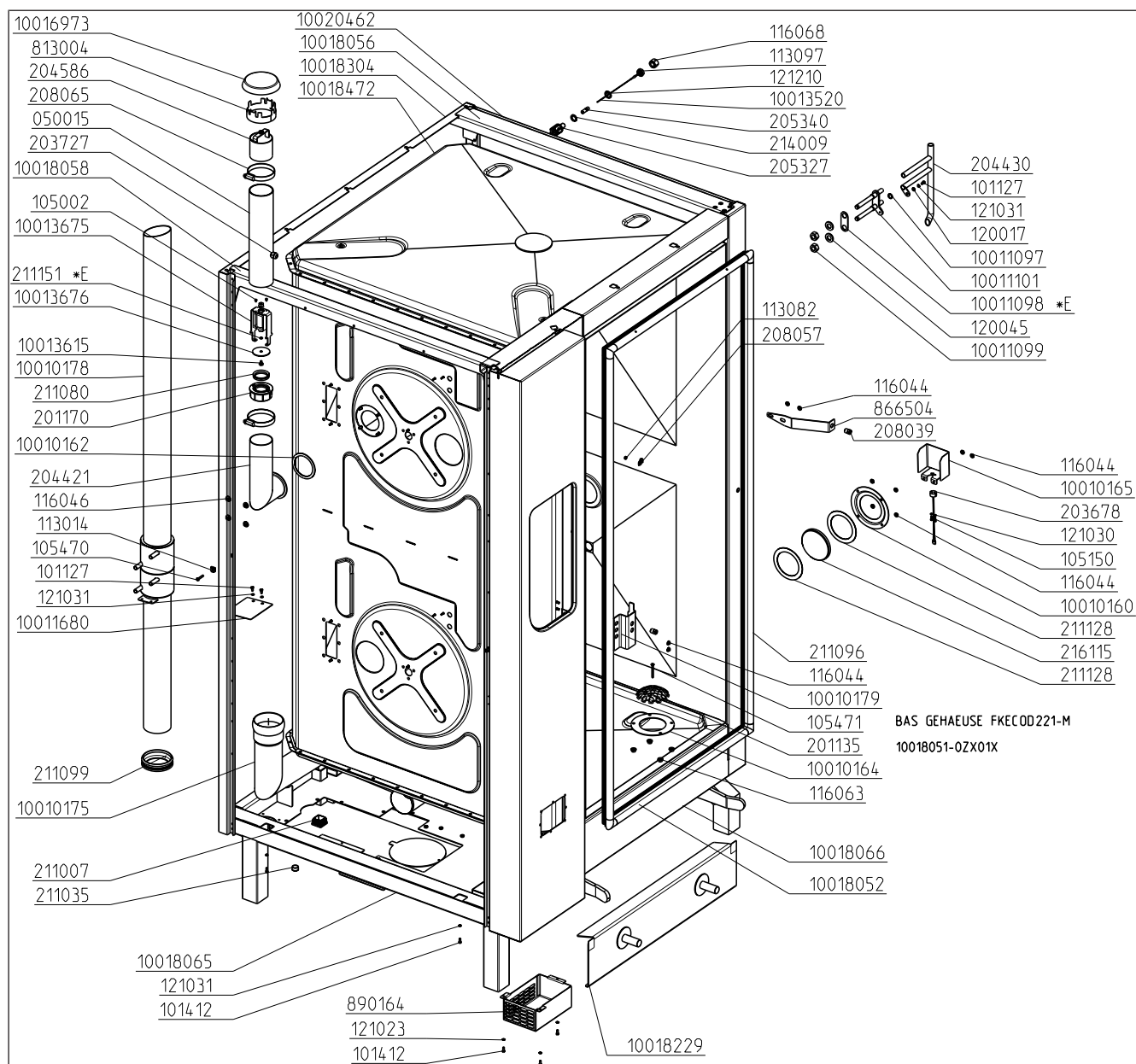

13 Carter - chambre de cuisson 20.x Gaz

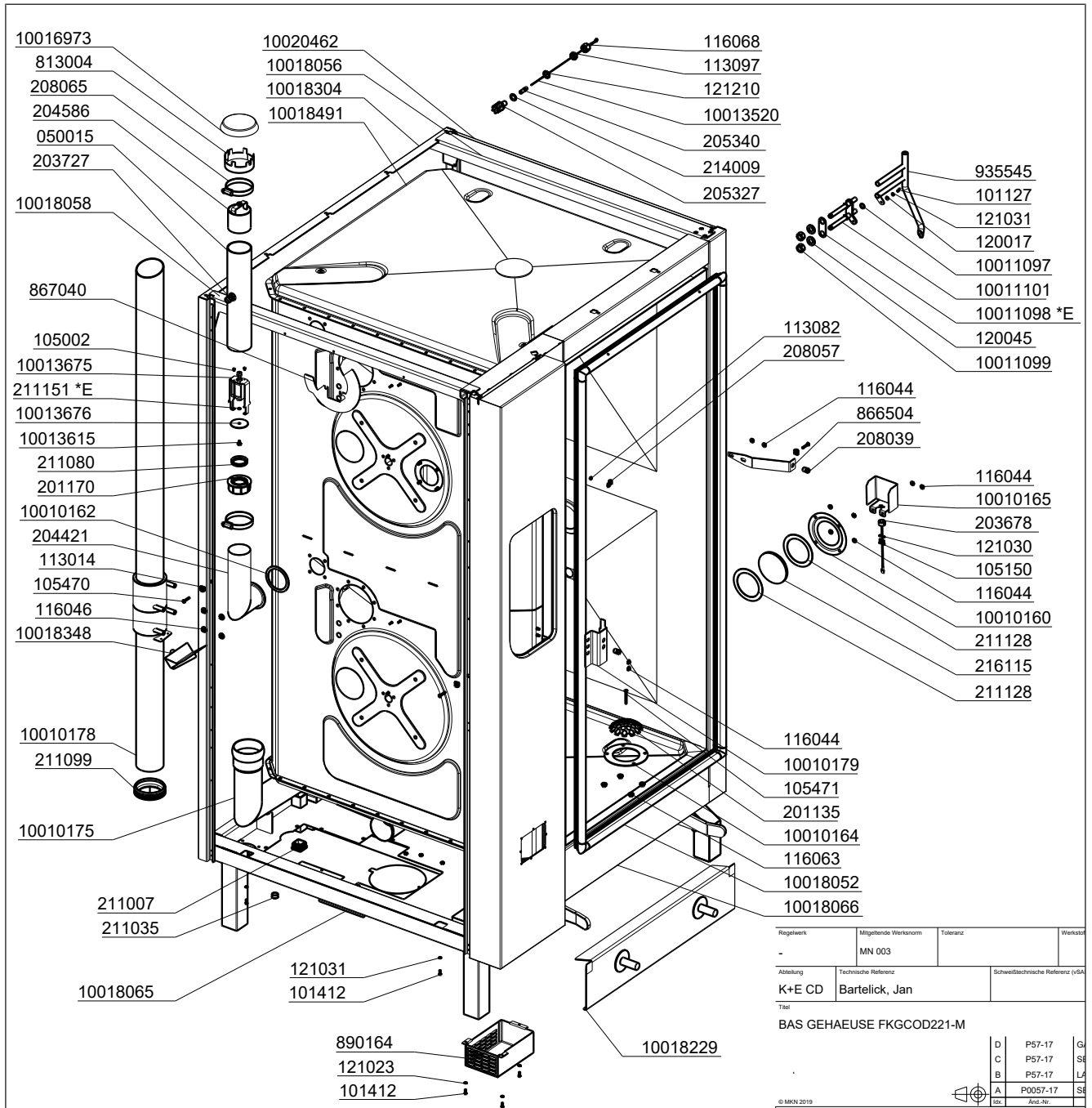

1000001199ZXFR-



15 Carter - porte de la chambre de cuisson gaz butée de droite

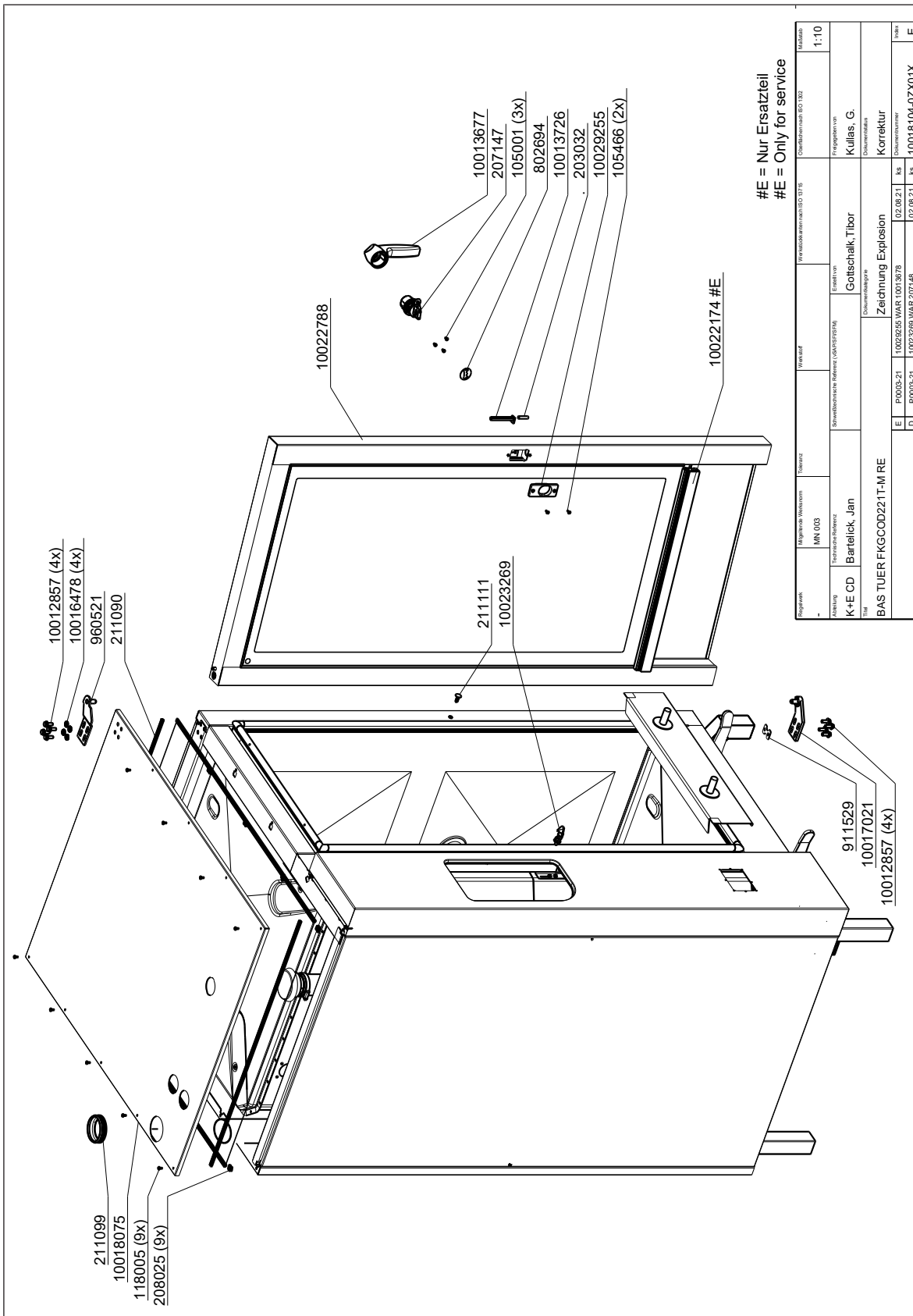

#E = Nur Ersatzteil
#E = Only for service

Projektnummer	Mitgliedsnummer	Technische Referenz	Werkstatt	Verantwortlicher	Zeichnungsnummer	Skala
-	MN 003	K-E CD	Bartelick, Jan	Gotschalk, Tibor	10022174 #E	1:10
Technische Referenz			Erstellt von		Freigegeben von	
BAS TUER FKG0221T-M RE			Gotschalk, Tibor		Kullas, G.	
Titel			Gezeichnet von		Gezeichnet am	
Zeichnung Explosion			Korrekturen		10018104-02X01X	
E P 0003-21			10022174 #E		10022174 #E	
D P 0003-21			10022174 #E		10022174 #E	

1000001199ZXR-



www.mkn.com

